

Owner's Manual & Safety Instructions

Save This Manual Keep this manual for the safety warnings and precautions, assembly, operating, inspection, maintenance and cleaning procedures. Write the product's serial number in the back of the manual near the assembly diagram (or month and year of purchase if product has no number). Keep this manual and the receipt in a safe and dry place for future reference.

17d



13" BENCH DRILL PRESS



Visit our website at: <http://www.harborfreight.com>
Email our technical support at: productsupport@harborfreight.com **38142**

When unpacking, make sure that the product is intact and undamaged. If any parts are missing or broken, please call 1-888-866-5797 as soon as possible.

Copyright© 1998 by Harbor Freight Tools®. All rights reserved.

No portion of this manual or any artwork contained herein may be reproduced in any shape or form without the express written consent of Harbor Freight Tools. Diagrams within this manual may not be drawn proportionally. Due to continuing improvements, actual product may differ slightly from the product described herein. Tools required for assembly and service may not be included.

⚠ WARNING

**Read this material before using this product.
Failure to do so can result in serious injury.
SAVE THIS MANUAL.**

Table of Contents

Safety	2	Maintenance	12
Specifications	6	Parts Lists and Diagrams	14
Setup	6	Warranty	16
Operation.....	9		

SAFETY



SETUP

OPERATION

MAINTENANCE

WARNING SYMBOLS AND DEFINITIONS	
	This is the safety alert symbol. It is used to alert you to potential personal injury hazards. Obey all safety messages that follow this symbol to avoid possible injury or death.
	Indicates a hazardous situation which, if not avoided, will result in death or serious injury.
	Indicates a hazardous situation which, if not avoided, could result in death or serious injury.
	Indicates a hazardous situation which, if not avoided, could result in minor or moderate injury.
	Addresses practices not related to personal injury.

IMPORTANT SAFETY INFORMATION

General Tool Safety Warnings

WARNING

Read all safety warnings and instructions.
Failure to follow the warnings and instructions may result in electric shock, fire and/or serious injury.
Save all warnings and instructions for future reference.

1. KEEP GUARDS IN PLACE and in working order.
2. REMOVE ADJUSTING KEYS AND WRENCHES. Form habit of checking to see that keys and adjusting wrenches are removed from tool before turning it on.
3. KEEP WORK AREA CLEAN. Cluttered areas and benches invite accidents.
4. DON'T USE IN DANGEROUS ENVIRONMENT. Don't use power tools in damp or wet locations, or expose them to rain. Keep work area well lighted.
5. KEEP CHILDREN AWAY. All visitors should be kept safe distance from work area.
6. MAKE WORKSHOP KID PROOF with padlocks, master switches, or by removing starter keys.
7. DON'T FORCE TOOL. It will do the job better and safer at the rate for which it was designed.
8. USE RIGHT TOOL. Don't force tool or attachment to do a job for which it was not designed.

General Tool Safety Warnings (cont.)

Table A: RECOMMENDED MINIMUM WIRE GAUGE FOR EXTENSION CORDS (120 VOLT)

NAMEPLATE AMPERES (at full load)	EXTENSION CORD LENGTH			
	25'	50'	100'	150'
0 – 6	18	16	16	14
6.1 – 10	18	16	14	12
10.1 – 12	16	16	14	12
12.1 – 16	14	12	Do not use.	

9. **USE PROPER EXTENSION CORD.** Make sure your extension cord is in good condition. When using an extension cord, be sure to use one heavy enough to carry the current your product will draw. An undersized cord will cause a drop in line voltage resulting in loss of power and overheating. Table A shows the correct size to use depending on cord length and nameplate ampere rating. If in doubt, use the next heavier gauge. The smaller the gauge number, the heavier the cord.
10. **WEAR PROPER APPAREL.** Do not wear loose clothing, gloves, neckties, rings, bracelets, or other jewelry which may get caught in moving parts. Nonslip footwear is recommended. Wear protective hair covering to contain long hair.
11. **ALWAYS USE SAFETY GLASSES.** Also use face or dust mask if cutting operation is dusty. Everyday eyeglasses only have impact resistant lenses, they are NOT safety glasses.
12. **SECURE WORK.** Use clamps or a vise to hold work when practical. It's safer than using your hand and it frees both hands to operate tool.
13. **DON'T OVERREACH.** Keep proper footing and balance at all times.
14. **MAINTAIN TOOLS WITH CARE.** Keep tools sharp and clean for best and safest performance. Follow instructions for lubricating and changing accessories.
15. **DISCONNECT TOOLS** before servicing; when changing accessories, such as blades, bits, cutters, and the like.
16. **REDUCE THE RISK OF UNINTENTIONAL STARTING.** Make sure switch is in off position before plugging in.
17. **USE RECOMMENDED ACCESSORIES.** Consult the owner's manual for recommended accessories. The use of improper accessories may cause risk of injury to persons.
18. **NEVER STAND ON TOOL.** Serious injury could occur if the tool is tipped or if the cutting tool is unintentionally contacted.
19. **CHECK DAMAGED PARTS.** Before further use of the tool, a guard or other part that is damaged should be carefully checked to determine that it will operate properly and perform its intended function – check for alignment of moving parts, binding of moving parts, breakage of parts, mounting, and any other conditions that may affect its operation. A guard or other part that is damaged should be properly repaired or replaced.
20. **DIRECTION OF FEED.** Feed work into a blade or cutter against the direction of rotation of the blade or cutter only.
21. **NEVER LEAVE TOOL RUNNING UNATTENDED. TURN POWER OFF.** Don't leave tool until it comes to a complete stop.

Grounding Instructions



⚠️ WARNING

TO PREVENT ELECTRIC SHOCK AND DEATH FROM INCORRECT GROUNDING WIRE CONNECTION, READ AND FOLLOW THESE INSTRUCTIONS:

110-120 VAC Grounded Tools: Tools with Three Prong Plugs

1. In the event of a malfunction or breakdown, grounding provides a path of least resistance for electric current to reduce the risk of electric shock. This tool is equipped with an electric cord having an equipment-grounding conductor and a grounding plug. The plug must be plugged into a matching outlet that is properly installed and grounded in accordance with all local codes and ordinances.
2. Do not modify the plug provided – if it will not fit the outlet, have the proper outlet installed by a qualified electrician.
3. Improper connection of the equipment-grounding conductor can result in a risk of electric shock. The conductor with insulation having an outer surface that is green with or without yellow stripes is the equipment-grounding conductor. If repair or replacement of the electric cord or plug is necessary, do not connect the equipment-grounding conductor to a live terminal.
4. Check with a qualified electrician or service personnel if the grounding instructions are not completely understood, or if in doubt as to whether the tool is properly grounded.
5. Use only 3-wire extension cords that have 3-prong grounding plugs and 3-pole receptacles that accept the tool's plug.

6. Repair or replace damaged or worn cord immediately.

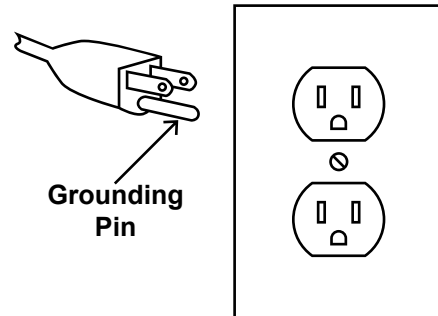

125 VAC 3-Prong Plug and Outlet
(for up to 125 VAC and up to 15 A)

7. This tool is intended for use on a circuit that has an outlet that looks like the one illustrated above in **125 VAC 3-Prong Plug and Outlet**. The tool has a grounding plug that looks like the plug illustrated above in **125 VAC 3-Prong Plug and Outlet**.
8. The outlet must be properly installed and grounded in accordance with all codes and ordinances.
9. Do not use an adapter to connect this tool to a different outlet.

Drill Press Safety Warnings

For Your Own Safety Read Instruction Manual Before Operating Drill Press

1. Wear eye protection.
2. Do not wear gloves, necktie, or loose clothing.
3. Clamp workpiece or brace against column to prevent rotation.
4. Use recommended speed for drill accessory and workpiece material.
5. The included chuck key is specially designed to be self-ejecting, reducing the risk of ejecting at high speed. Only use the included chuck key or an identical replacement key.
6. **DO NOT OPERATE WITH ANY GUARD DISABLED, DAMAGED, OR REMOVED. Moving guards must move freely and close instantly.**
7. The use of accessories or attachments not recommended by the manufacturer may result in a risk of injury to persons.
8. When servicing use only identical replacement parts.
9. Do not depress the spindle lock when starting or during operation.
10. Only use safety equipment that has been approved by an appropriate standards agency. Unapproved safety equipment may not provide adequate protection. Eye protection must be ANSI-approved and breathing protection must be NIOSH-approved for the specific hazards in the work area.

Drill Press Safety Warnings (cont.)

11. Stay alert, watch what you are doing and use common sense when operating a power tool. Do not use a power tool while you are tired or under the influence of drugs, alcohol or medication. A moment of inattention while operating power tools may result in serious personal injury.
12. Industrial applications must follow OSHA guidelines.
13. Maintain labels and nameplates on the tool. These carry important safety information. If unreadable or missing, contact Harbor Freight Tools for a replacement.
14. Avoid unintentional starting. Prepare to begin work before turning on the tool.
15. People with pacemakers should consult their physician(s) before use. Electromagnetic fields in close proximity to heart pacemaker could cause pacemaker interference or pacemaker failure.
16. **WARNING:** Some dust created by power sanding, sawing, grinding, drilling, and other construction activities, contains chemicals known to the State of California to cause cancer and birth defects or other reproductive harm. Some examples of these chemicals are:
 - Lead from lead-based paints
 - Crystalline silica from bricks and cement or other masonry products
 - Arsenic and chromium from chemically treated lumberYour risk from these exposures varies, depending on how often you do this type of work. To reduce your exposure to these chemicals: work in a well ventilated area, and work with approved safety equipment, such as those dust masks that are specially designed to filter out microscopic particles. (California Health & Safety Code § 25249.5, *et seq.*)
17. **WARNING:** The cord of this product contains lead and/or di (2-ethylhexyl) phthalate (DEHP), chemicals known to the State of California to cause cancer, and birth defects or other reproductive harm. Wash hands after handling. (California Health & Safety Code § 25249.5, *et seq.*)
18. The warnings, precautions, and instructions discussed in this instruction manual cannot cover all possible conditions and situations that may occur. It must be understood by the operator that common sense and caution are factors which cannot be built into this product, but must be supplied by the operator.

Vibration Safety

This tool vibrates during use. Repeated or long-term exposure to vibration may cause temporary or permanent physical injury, particularly to the hands, arms and shoulders. To reduce the risk of vibration-related injury:

1. Anyone using vibrating tools regularly or for an extended period should first be examined by a doctor and then have regular medical check-ups to ensure medical problems are not being caused or worsened from use. Pregnant women or people who have impaired blood circulation to the hand, past hand injuries, nervous system disorders, diabetes, or Raynaud's Disease should not use this tool. If you feel any medical or physical symptoms related to vibration (such as tingling, numbness, and white or blue fingers), seek medical advice as soon as possible.
2. Do not smoke during use. Nicotine reduces the blood supply to the hands and fingers, increasing the risk of vibration-related injury.
3. Use tools with the lowest vibration when there is a choice between different processes.
4. Include vibration-free periods each day of work.
5. Grip tool as lightly as possible (while still keeping safe control of it). Let the tool do the work.
6. To reduce vibration, maintain the tool as explained in this manual. If any abnormal vibration occurs, stop use immediately.



SAVE THESE INSTRUCTIONS.

Specifications

Motor Power	3/4 HP - 16 speeds ranging from 220 to 3600 RPM
Electrical Rating	120VAC, 60Hz, 7.5A, Single-Phase
Drill Chuck Capacity	7/64" to 5/8"
Spindle Stroke	3-1/8"
Swing	13-1/4"
Column Diameter	2- 57/64"
Dry Table	11-1/2" Diameter
Table Slot	1/2"
Overall Height	41-3/4"
Weight	110 lbs.
Product Use	For heavy-duty use on metal, plastic or wood materials. Table rotates 360° and tilts 0-45° in 1° increments.

Setup - Before Use:



Read the **ENTIRE IMPORTANT SAFETY INFORMATION** section at the beginning of this manual including all text under subheadings therein before set up or use of this product.

WARNING

TO PREVENT SERIOUS INJURY FROM ACCIDENTAL OPERATION:

Turn the Power Switch of the tool off and unplug the tool from its electrical outlet before performing any procedure in this section.

Note: For additional information regarding the parts listed in the following pages, refer to the Assembly Diagram near the end of this manual.

Mounting

Secure the tool to a supporting structure before use. Before assembly, bolt the Base to a flat, level, solid workbench capable of supporting the weight of the drill press and any workpieces.

Verify that installation surface has no hidden utility lines before drilling or driving screws.

Assembly

Column Assembly to Base

1. With the Base (6B) on a flat level surface, bolt on the Column Support (4B) using the four M10x40mm Hex Head screws (5B).
2. Tighten firmly.
3. Insert the Column (1B) into its Support (4B) and firmly secure with the Hex socket set screws (3B).

Note: It may be necessary to screw out the set screws beforehand, as they may protrude into the tube preventing the column from sliding in fully.

Table and Support Arm to Column

1. Remove the Rack (2B) from the Column (1B) by slackening off the Collar Set Screw (11B) and removing the Collar (19B). The rack is stowed in this position only for transit purposes.
2. Lubricate the Worm Gear (18B) with light grease, and insert shaft first into Worm Gear Housing in the Arm which should fully mesh with the Helical Gear (17B). Hold it in this position. The Worm Gear Shaft will extend through the housing to be ready for the crank to be attached in a later step.
3. Gently slide the arm assembly over the column and hold it steady while inserting the Rack (2B) down through the Worm Gear Housing, meshing with the Helical Gear (17B), ensuring the long smooth end of the rack is uppermost. The bottom end of the rack will be located in the groove formed by the column support and the column.
4. Hold the machine in this position while replacing the collar on the column, and ensure that the end of the Rack (2B) is firmly engaged in the groove formed between the collar and the column. However, make sure the Rack is not pinched and there is a working clearance between the Rack (2B) and Collar (19B).
5. Firmly secure the Collar (19B) with the Set screw (11B).
6. Thread the Arm Locking Handle (16B) in from the left, and tighten to secure the arm to the column.
7. Attach the Table Crank (8B) to its spigot and tighten the securing screw.
8. Slacken off the arm locking handle and turn the crank, testing to ensure that the arm will move the full length of the rack easily, without binding, and will also rotate about the column evenly, and without binding.
9. IF TOO TIGHT, Nudge up the Arm Locking Handle and slacken off the Collar Set Screw. Adjust to give a greater working clearance between the rack and collar, tighten the set screw, and test again.
10. Insert the table into its housing on the arm and secure with the Table Clamp (13B).

Head to Column

1. It may be necessary to unscrew the Head Lock Set Screws (21A) slightly to ensure they do not protrude internally, as this would prevent the head from sliding fully into position.
2. With assistance, raise the Head (1A) and locate it on top of the Column.
3. Align the head with the base, and firmly secure with the Set Screws (21A).
4. Screw the three Feed Handles (24A) and screw them firmly into the hub of the Spindle Feed Shaft (25A).

Installing the Chuck

1. With the Chuck Guard lifted clear of the spindle nose, slide the work table up the column to within 6" of the spindle.
2. Open the jaws of the chuck to their maximum, using the Chuck Key supplied.
3. Put a piece of scrap wood on the table to protect the Chuck Nose.
4. Ensuring all parts are thoroughly clean and dry and burr free, insert the Arbor (14) firmly into the end of the Chuck (15).
5. Insert the other end of the arbor, with the chuck now attached, into the end of the Spindle Shaft (13), turning, where necessary, to ensure that the point on the end of the arbor locates correctly with the drive slot in the spindle shaft.
6. Pull the spindle down using the feed handles, pressing the chuck nose hard against a piece of scrap wood on the table, to press the chuck into place.

Pulley Cover Knob

Locate the knob with Pan Head Screw (22) and attach to the cover. Screw on tightly.

Installing the Drive Belts

1. Undo the Belt Tension Locking Knobs (18A) on both sides of the head. Turn the Belt Tension Lever (19A) clockwise to bring the Motor Pulley (11A) close to the Spindle Pulley allowing the belts to be slipped on with ease.
2. Lubricate the Idler Pivot Shaft (20) and Idler Pulley (19), with light grease, and install in its mounting between the motor and spindle pulleys.
3. Consult the chart inside the pulley cover (or the Drill Speed chart in this manual), and install the belts in the positions corresponding to spindle/drill speed required.
4. Turn the Belt Tension Lever (19A) counterclockwise so that tension is applied to the belts (see Head Assembly diagram). Tension is correct when the belts deflect by approximately 1/2" at their centers of run when using reasonable thumb pressure. Lock the motor in this position with the locking knob.

Functions

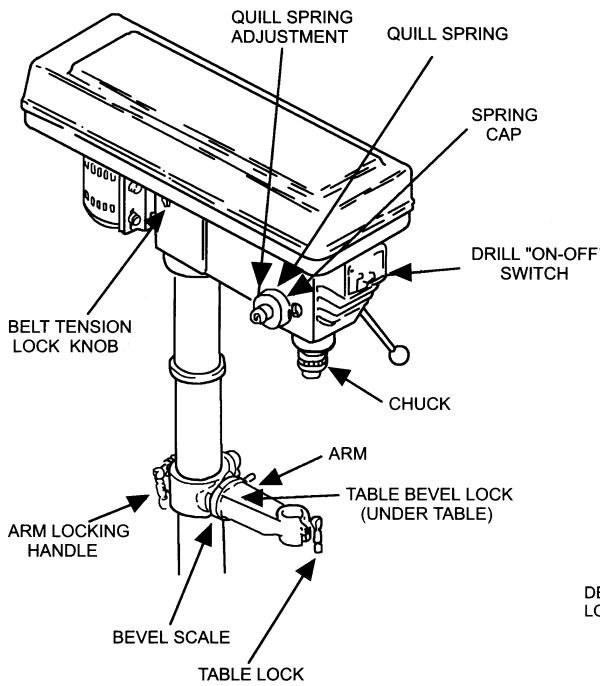

QUILL AND SPINDLE ASSEMBLY
INSIDE OF DRILL PRESS

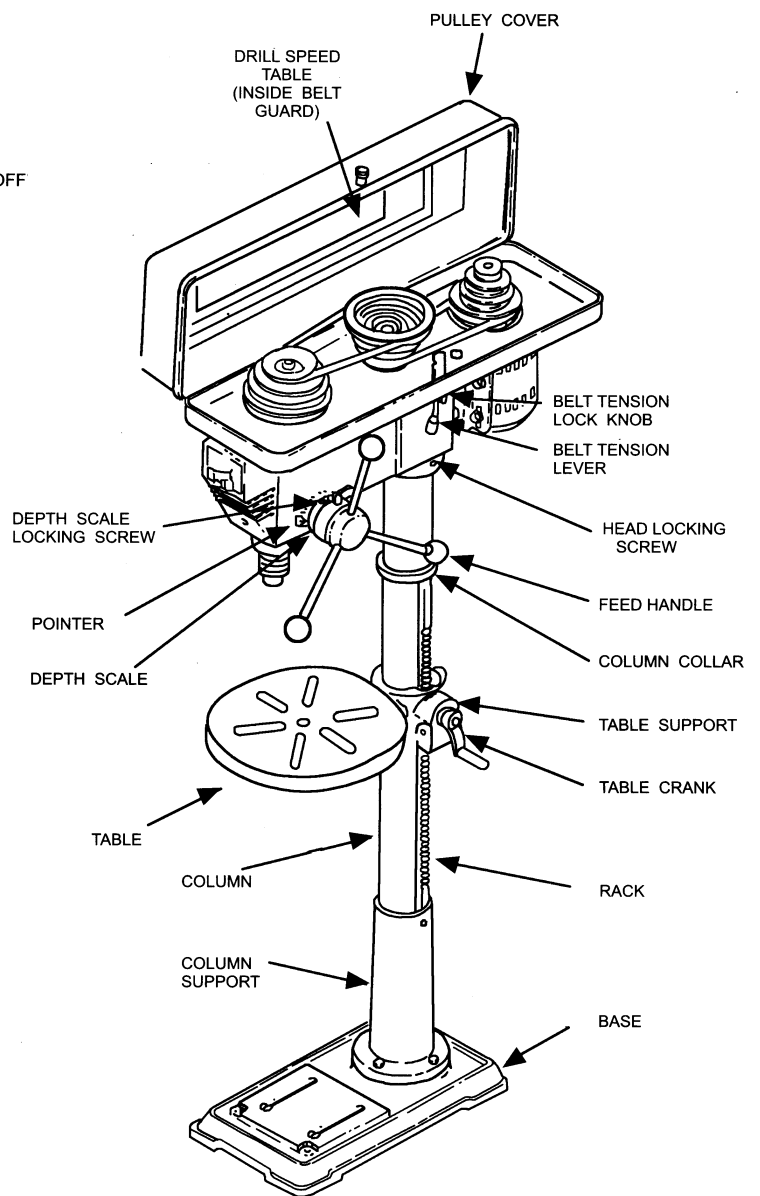
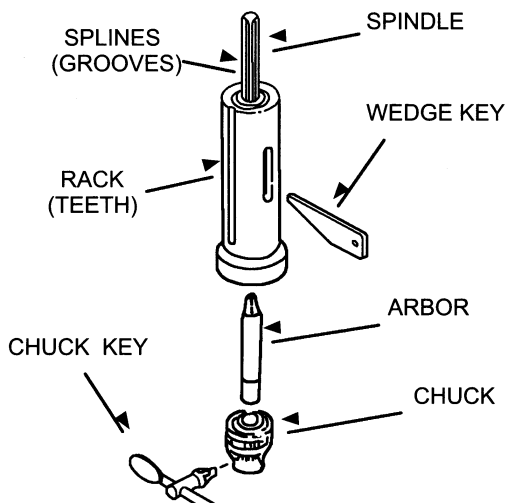

Operating Instructions



Read the **ENTIRE IMPORTANT SAFETY INFORMATION** section at the beginning of this manual including all text under subheadings therein before set up or use of this product.

Tool Set Up

WARNING

TO PREVENT SERIOUS INJURY FROM ACCIDENTAL OPERATION:
Turn the Power Switch of the tool off and unplug the tool from its electrical outlet before performing any procedure in this section.

TO PREVENT SERIOUS INJURY: DO NOT OPERATE WITH ANY GUARD DISABLED, DAMAGED, OR REMOVED. Moving guards must move freely and close instantly.

Table Adjustment

The table is capable of moving in four directions.

1. Raise or lower the table by slackening off the arm locking handle (A) and turning the crank (C), clockwise to raise and counterclockwise to lower.
2. Swivel the table about the column by slackening off the arm locking handle. The table assembly, arm and rack (B), move as one around the column.
3. Tilt the table by slackening the Bevel Table Locking Screw (E), and tilting to the required angle. A scale (F) is provided on the arm measured in degrees, to assist in setting the required angle. For all normal operations the table should be set at 0°.
4. TO ENSURE THAT THE DRILL IS ENTIRELY PERPENDICULAR TO THE TABLE, insert a piece of straight round bar in the chuck, place a square on the table and bring it up to the round bar. Adjust the table tilt if necessary so that the table is correctly aligned.
5. Turn the table about its axis, by slackening off clamp (D).

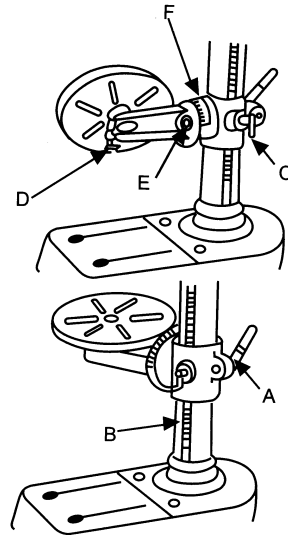

Figure A: Table Adjustment

Setting a Drilling Depth

Located around the Spindle Feed Shaft is a Depth Stop Collar (A) carrying a graduated scale. The collar is capable of turning about the shaft, and may be locked in place by a Locking Screw (B).

The graduations are in inches and metric.

1. Lower the drill (with the power OFF) so that it contacts the material and hold in that position.
2. Slacken off the locking screw and turn the collar so that the measurement for the depth of the hole required is in line with the pointer (C).
3. Lock the collar in this position using the locking screw.

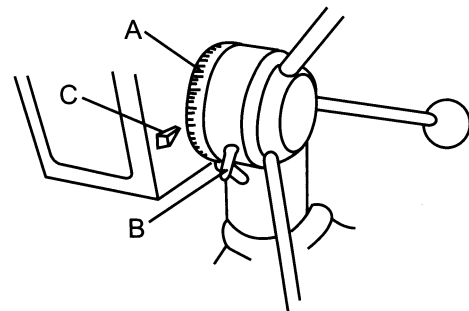

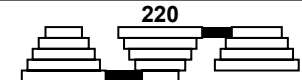
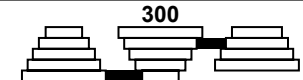
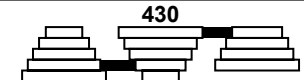

Figure B: Drill Depth Adjustment

Changing Drill Speed

Before changing the speeds, make sure the machine is switched OFF and UNPLUGGED.

1. Open the pulley cover.
2. Slacken off the Belt Tension Lock Knobs (18A) on both sides of the head and turn the Belt Tension Lever (19A) clockwise, to bring the Motor Pulley (11A) closer to the Spindle Pulley (3) in order to remove all tension from the Drive Belts (sizes M24, M25).
3. Consult the chart inside the pulley cover and position the belts on the pulley's according to the spindle which corresponds to the spindle/drill speed required.
4. When the belts have been correctly positioned, tighten them by turning the Belt Tension Lock Knobs (18A) until the belt deflects by approximately 1/2" at its center when using reasonable thumb pressure. Lock this position in with the two Locking Knobs (18A).

Note: If the belt is too long to be properly tensioned, it must be replaced.

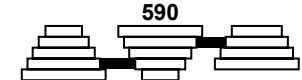
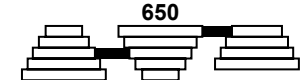
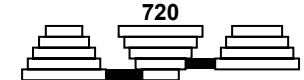
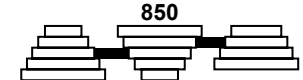
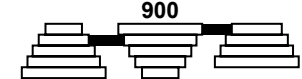
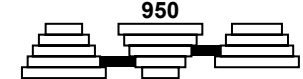
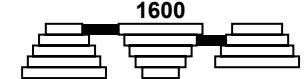
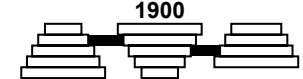
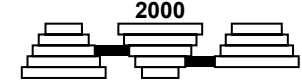
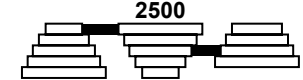
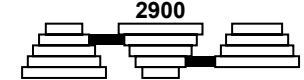
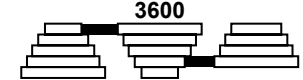
M24 Left Belt

M25 Right Belt

Figure C: Drill Speed Table

The table above shows the belt arrangements for given drill speeds (A full chart is also located on the inside of the pulley cover).

Bit Installation

Insert the drill into the jaws of the chuck approximately 1", ensuring that the jaws do not touch the flutes of the drill. Before tightening the chuck, ensure that the drill is centered within the jaws.



Workpiece and Work Area Set Up

1. Designate a work area that is clean and well-lit. The work area must not allow access by children or pets to prevent distraction and injury.
2. Route the power cord along a safe route to reach the work area without creating a tripping hazard or exposing the power cord to possible damage. The power cord must reach the work area with enough extra length to allow free movement while working.
3. Secure loose workpieces using a vise or clamps (not included) to prevent movement while working.
4. There must not be objects, such as utility lines, nearby that will present a hazard while working.
5. Make sure the table height and position is set so that the drill travel range is sufficient for the material to be drilled.
6. Make sure the work is securely clamped. That is, held in a drill vise, or bolted to the table. Never hold the material with your bare hands while drilling. Severe personal injury may be caused if the material is flung out of the operator's hand.
7. IF THE MATERIAL IS IRREGULARLY SHAPED and cannot be laid flat on the table, it should be securely blocked and clamped. Any tilting, twisting or shifting will result not only in a roughly drilled hole but also increases the chances of damage to the drill.
8. FOR FLAT WORK, lay the piece on to a wooden base and clamp it down firmly against the table to prevent it from turning.
9. FOR SMALL MATERIALS that cannot be clamped to the table, use a drill press vise. Make sure the vise is clamped or bolted to the table.
10. WHEN DRILLING COMPLETELY THROUGH WOOD, always position a piece of scrap wood between the material and the table to prevent splintering on the underside of the material as the drill breaks through. The scrap piece of wood must make contact with the left side of the column. Securely clamp the other end of the scrap wood to the table. Also, set the depth of the drill so that the drill will not come in contact with the table - or align the table so that the hole in its center is in line with the drill bit.

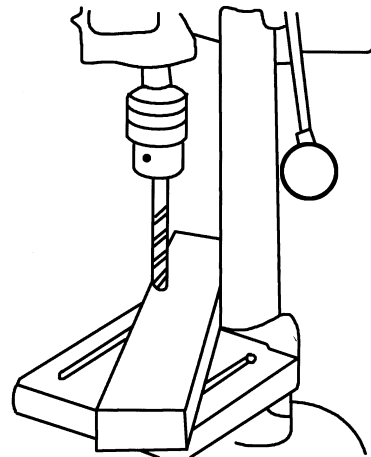

Figure D: Bracing workpiece against column

General Operating Instructions

1. Bring the drill bit down with the Feed Knob to where the hole is to be drilled. Make minor workpiece alignment adjustments.
2. Plug the Power Cord into an electrical outlet.
3. Turn the Drill Press on.
4. Pull down on the Feed Knob and slowly drill the hole into the workpiece.
5. To prevent accidents, turn off the tool and disconnect its power supply after use. Clean, then store the tool indoors out of children's reach.

WARNING! If the drill bit grabs and spins the workpiece, do not attempt to stop the spinning with your hands. Step back, and turn the drill press off. Wait for the spindle to stop turning before dislodging the workpiece.

Maintenance and Servicing



Procedures not specifically explained in this manual must be performed only by a qualified technician.

WARNING

TO PREVENT SERIOUS INJURY FROM ACCIDENTAL OPERATION:

Turn the Power Switch of the tool off and unplug the tool from its electrical outlet before performing any procedure in this section.

TO PREVENT SERIOUS INJURY FROM TOOL FAILURE:

Do not use damaged equipment. If abnormal noise or vibration occurs, have the problem corrected before further use.

Cleaning, Maintenance, and Lubrication

1. **BEFORE EACH USE**, inspect the general condition of the tool. Check for:
 - loose hardware,
 - misalignment or binding of moving parts,
 - cracked or broken parts,
 - damaged electrical wiring, and
 - any other condition that may affect its safe operation.
2. **AFTER USE**, wipe external surfaces of the tool with clean cloth.
3. **WARNING!** If the supply cord of this power tool is damaged, it must be replaced only by a qualified service technician.

Belt Inspection and Tensioning

1. Examine belt for cracks, tears in the backing, and other damage.
2. Replace belt if damaged, following the instructions under Changing Drill Speed on page 10.

Troubleshooting

Problem	Possible Causes	Likely Solutions
Tool will not start.	<ol style="list-style-type: none"> 1. Cord not connected. 2. No power at outlet. 3. Tool's thermal reset breaker tripped (if equipped). 4. Internal damage or wear. (Carbon brushes or switch, for example.) 	<ol style="list-style-type: none"> 1. Check that cord is plugged in. 2. Check power at outlet. If outlet is unpowered, turn off tool and check circuit breaker. If breaker is tripped, make sure circuit is right capacity for tool and circuit has no other loads. 3. Turn off tool and allow to cool. Press reset button on tool. 4. Have technician service tool.
Tool operates slowly.	Extension cord too long or wire size too small.	Eliminate use of extension cord. If an extension cord is needed, use one with the proper diameter for its length and load. See Table A on page 3.
Performance decreases over time.	<ol style="list-style-type: none"> 1. Accessory dull or damaged. 2. Carbon brushes worn or damaged. 	<ol style="list-style-type: none"> 1. Keep cutting accessories sharp. Replace as needed. 2. Have qualified technician replace brushes.
Excessive noise or rattling.	<ol style="list-style-type: none"> 1. Internal damage or wear. (Carbon brushes or bearings, for example.) 2. Belt (if equipped) too loose (slipping) or too tight (bearing damage). 	<ol style="list-style-type: none"> 1. Have technician service tool. 2. Properly tension belt.
Overheating.	<ol style="list-style-type: none"> 1. Forcing machine to work too fast. 2. Accessory dull or damaged. 3. Blocked motor housing vents. 4. Motor being strained by long or small diameter extension cord. 	<ol style="list-style-type: none"> 1. Allow machine to work at its own rate. 2. Keep cutting accessories sharp. Replace as needed. 3. Wear ANSI-approved safety goggles and NIOSH-approved dust mask/respirator while blowing dust out of motor using compressed air. 4. Eliminate use of extension cord. If an extension cord is needed, use one with the proper diameter for its length and load. See Table A on page 3.



Follow all safety precautions whenever diagnosing or servicing the tool. Disconnect power supply before service.

PLEASE READ THE FOLLOWING CAREFULLY

THE MANUFACTURER AND/OR DISTRIBUTOR HAS PROVIDED THE PARTS LIST AND ASSEMBLY DIAGRAM IN THIS MANUAL AS A REFERENCE TOOL ONLY. NEITHER THE MANUFACTURER OR DISTRIBUTOR MAKES ANY REPRESENTATION OR WARRANTY OF ANY KIND TO THE BUYER THAT HE OR SHE IS QUALIFIED TO MAKE ANY REPAIRS TO THE PRODUCT, OR THAT HE OR SHE IS QUALIFIED TO REPLACE ANY PARTS OF THE PRODUCT. IN FACT, THE MANUFACTURER AND/OR DISTRIBUTOR EXPRESSLY STATES THAT ALL REPAIRS AND PARTS REPLACEMENTS SHOULD BE UNDERTAKEN BY CERTIFIED AND LICENSED TECHNICIANS, AND NOT BY THE BUYER. THE BUYER ASSUMES ALL RISK AND LIABILITY ARISING OUT OF HIS OR HER REPAIRS TO THE ORIGINAL PRODUCT OR REPLACEMENT PARTS THERETO, OR ARISING OUT OF HIS OR HER INSTALLATION OF REPLACEMENT PARTS THERETO.

Record Product's Serial Number Here: _____

Note: If product has no serial number, record month and year of purchase instead.

Note: Some parts are listed and shown for illustration purposes only, and are not available individually as replacement parts.

Pulley and Spindle Parts List and Diagram

SAFETY

SETUP

OPERATION

MAINTENANCE

Part #	Description	Code
1	"V" Belt M24	1505010
2	Pulley Nut	1302025
3	Spindle Pulley	1305009-02
4	Pulley Insert	1302022
5	Ball Bearing	60203
6	Spacer	1302023
7	Retaining Ring	17mm
8	Retaining Ring	11mm
9	Ball Bearing	60201
10	Quill Gasket	1303003
11	Quill	13030002B
12	Ball Bearing	60204
13	Spindle Shaft	13003001A

Part #	Description	Code
14	Arbor	1503007
15	Chuck	1503009A
16	Chuck Key	1503010A
17	Wedge Drift	1503008
18	Ball Bearing	60202
19	Idler Pulley	1505006-02
20	Idler Pivot	1705007
21	Knot	1505008
22	Pan Head Screw M5x8	
23	Pulley Cover	13050000A
24	Washer HD Screw	M16x12
25	Foam Washer	0805009
26	"V" Belt M26	1505011

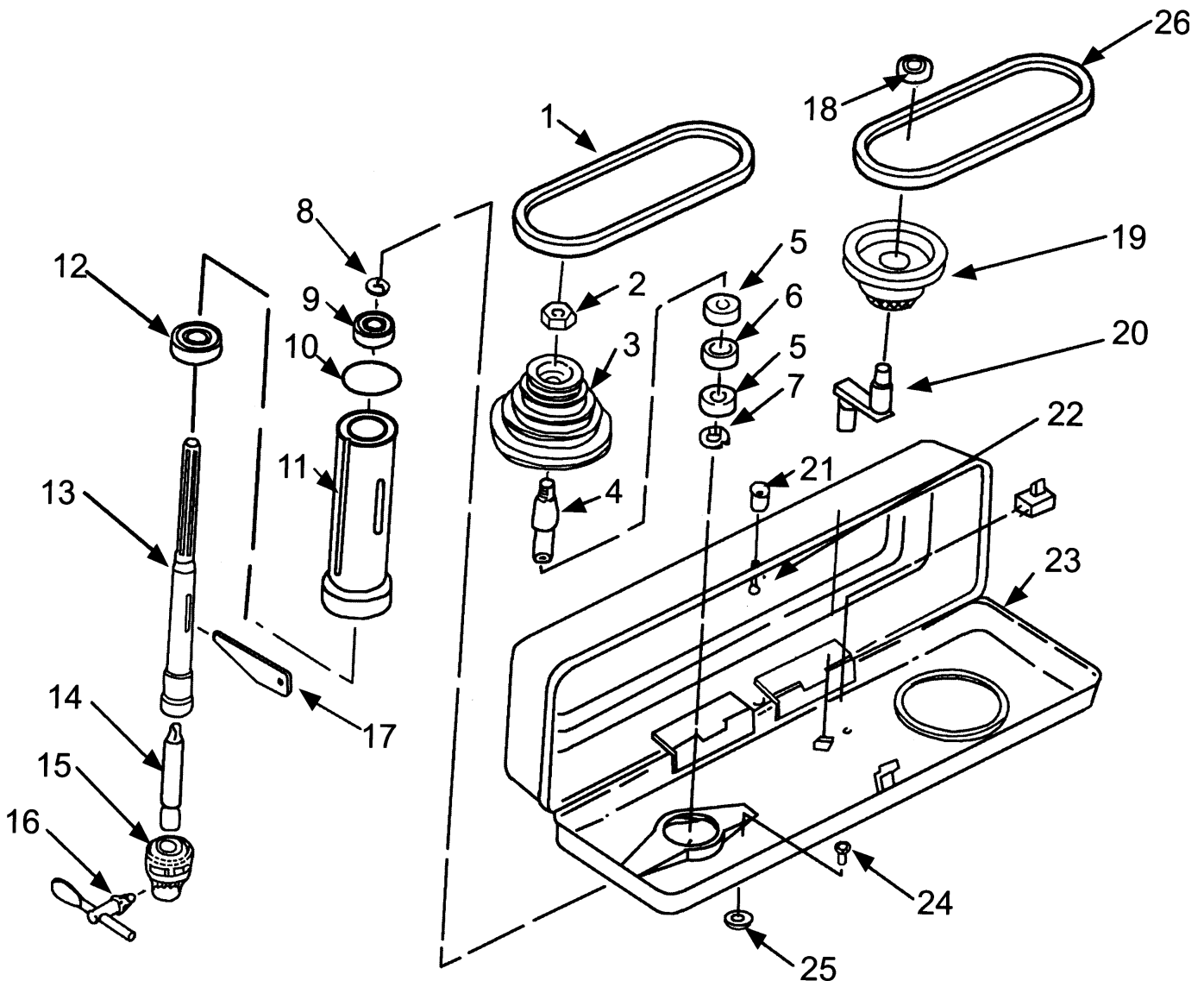

Parts List and Diagram A - Head

Note: All part numbers shown in this diagram have an "A" suffix

Part #	Description	Code
1A	Head w/pointer and trim	1302001A
2A	Cable Clamp	1502014A
3A	Pan Head Screw	M5x12
4A	Hex. Screw	M8x16
5A	Adjusting Lever	1502006
6A	Motor Support Bracket	1502002
7A	Motor Support Bracket	1502003
8A	Motor Mount	1502007
9A	Lockwasher	~12
10A	Nut Hex.	M12 x 1.75
11A	Motor Pulley	1505005-02
12A	Skt. Screw Set	M6x10
13A	Motor	B881262
14A	Hex. Nut	M8
15A	Washer	~8
16A	Motor Cable	1502016
17A	Hex Screw	M8x20
18A	Belt Tension Lock Knob	1502005
19A	Belt Tension Lever	1502004
20A	Roll Pin	6x26
21A	Head Lock Set Screw	M8x25
22A	Depth Lock Screw	1504012
23A	Knob	1304011

Part #	Description	Code
24A	Feed Handle	1304005
25A	Spindle Feed Shaft	1304002
26A	Collar Depth Stop, w/scale	1304003
27A	Stop Pin	1304010
28A	Connector Wire	1502019
29A	Lockwasher Ext. 5mm	~5
30A	Pan Head Screw M5	M5x12
31A	Switch	1502010-01
33A	Switch Plate Cover	1502009-01
34A	Pan Head Screw	ST4.2x9.5
35A	Pan Head Screw M5	M5x12
36A	Switch Box	E1302008
37A	Screw-Special Set M8	1302021
38A	Hex. Nut M12	M12x1.5
39A	Quill Spring Cap	1504008
40A	Quill Spring	1504009
41A	—	—
42A	—	—
43A	Power Cable	1302015
44A	Cable Tie	1502017
45A	Hex Key	4mm
46A	Hex Key	3mm

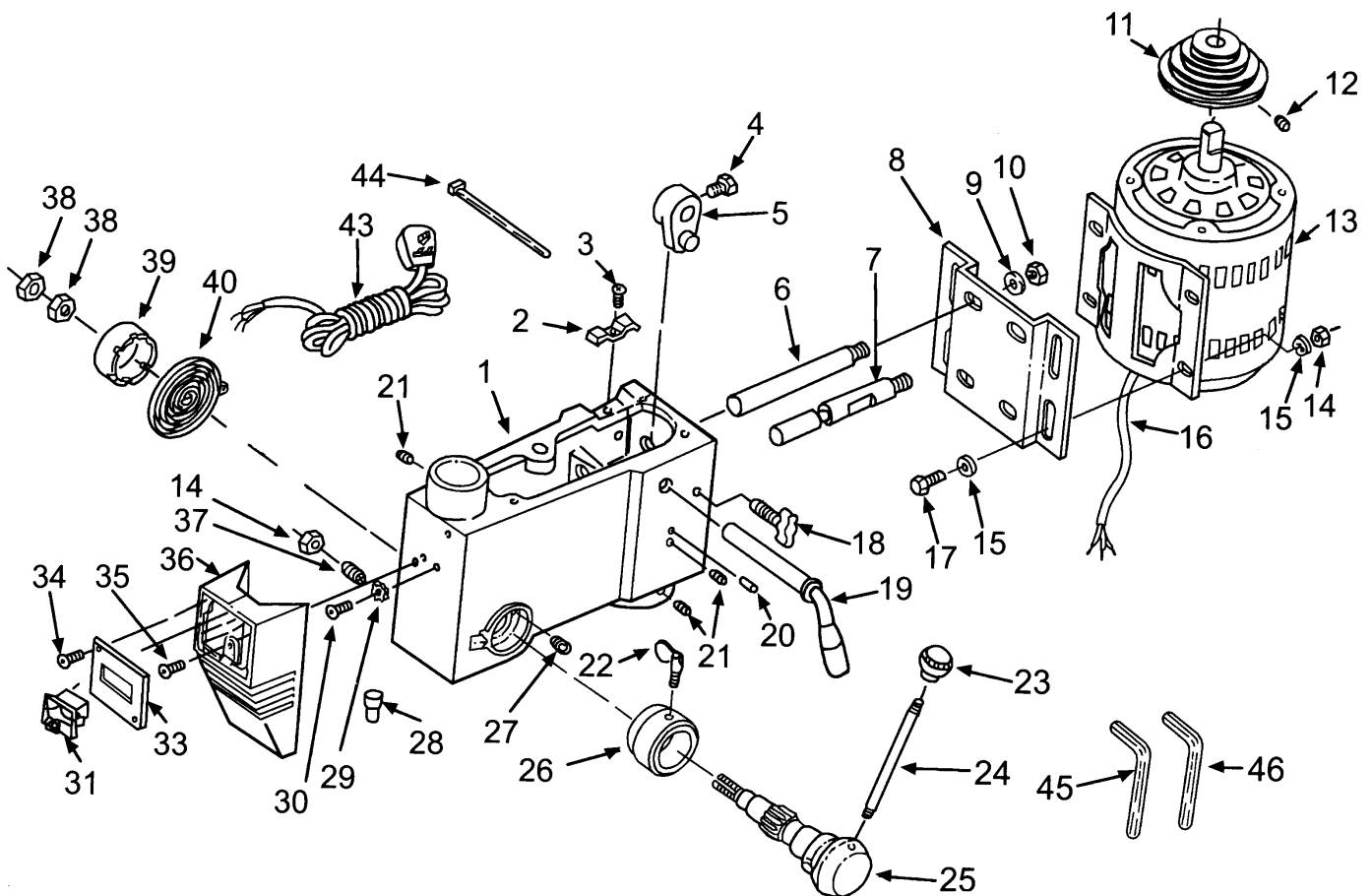

SAFETY

SETUP

OPERATION

MAINTENANCE

Parts List and Diagram B - Base and Table

Note: All part numbers shown in this diagram have an "B" suffix

Part #	Description	Code
1B	Column	1501003
2B	Rack	1501010
3B	Hex. Socket Screw Set	M10x12
4B	Column Support	1501002
5B	Hex. Head Screw	M10x40
6B	Base	1301001
7B	Table Support w/indicator	1501004
8B	Crank	1001009
11B	Skt. Screw Set M6	M6x10
12B	Bevel Table Lock Screw	M16x35
13B	Table Clamp	1501013
14B	Arm w/ scale	1301005
15B	Table	1601014
16B	Arm Locking Handle	1501012
17B	Helical Gear	1501006
18B	Worm	1501008
19B	Collar	1501011
19A	Belt Tension Lever	1502004

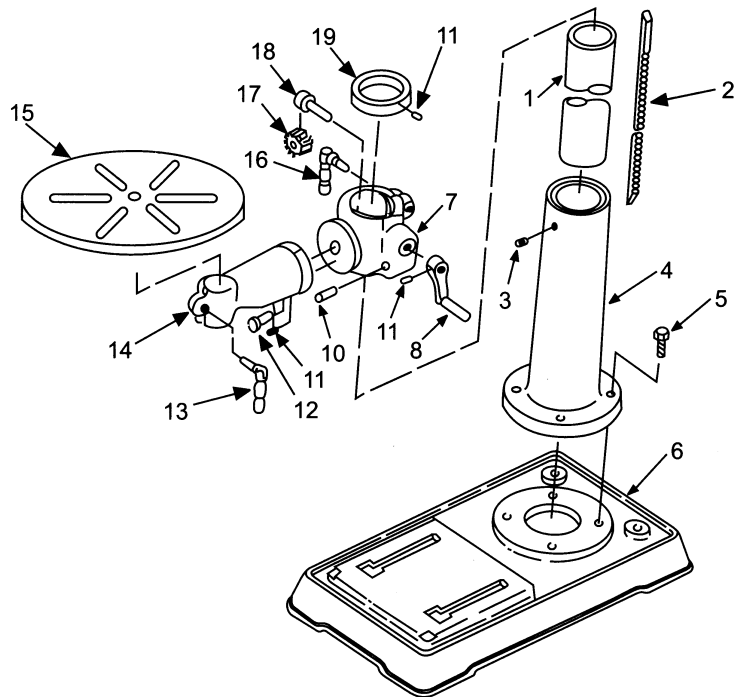

Limited 90 Day Warranty

Harbor Freight Tools Co. makes every effort to assure that its products meet high quality and durability standards, and warrants to the original purchaser that this product is free from defects in materials and workmanship for the period of 90 days from the date of purchase. This warranty does not apply to damage due directly or indirectly, to misuse, abuse, negligence or accidents, repairs or alterations outside our facilities, criminal activity, improper installation, normal wear and tear, or to lack of maintenance. We shall in no event be liable for death, injuries to persons or property, or for incidental, contingent, special or consequential damages arising from the use of our product. Some states do not allow the exclusion or limitation of incidental or consequential damages, so the above limitation of exclusion may not apply to you. THIS WARRANTY IS EXPRESSLY IN LIEU OF ALL OTHER WARRANTIES, EXPRESS OR IMPLIED, INCLUDING THE WARRANTIES OF MERCHANTABILITY AND FITNESS.

To take advantage of this warranty, the product or part must be returned to us with transportation charges prepaid. Proof of purchase date and an explanation of the complaint must accompany the merchandise. If our inspection verifies the defect, we will either repair or replace the product at our election or we may elect to refund the purchase price if we cannot readily and quickly provide you with a replacement. We will return repaired products at our expense, but if we determine there is no defect, or that the defect resulted from causes not within the scope of our warranty, then you must bear the cost of returning the product.

This warranty gives you specific legal rights and you may also have other rights which vary from state to state.



3491 Mission Oaks Blvd. • PO Box 6009 • Camarillo, CA 93011 • 1-888-866-5797