

This book has been reprinted from the original publication without revisions except the addition of the Safety Precautions.
The Cincinnati Grinders Incorporated, by change of name, is now Cincinnati Milacron, Inc.

WARNING

In order to clearly show details of this machine, some covers, shields, doors, guards or other protective devices have either been removed or shown in an "open" position. All such protective devices shall be installed in position before operating this machine. Failure to follow this instruction may result in damage to machine components and/or personal injury.

OPERATOR'S INSTRUCTION BOOK

for
CINCINNATI MILACRON®
NOS. 2, 3 and 4
DIAL TYPE
MILLING MACHINES

PUBLICATION NO. M-875-8

IMPORTANT

Carefully read the instructions and safety precautions given in this manual. Do not operate and/or service this machine/equipment until you have read this manual thoroughly.

At the time of writing, the book was completely up-to-date. However, due to continual improvements in design, it is possible that descriptions contained herein may vary to a slight extent from the machine delivered to you. This merely implies that the machine has been improved to better fulfill your requirements. If there are any questions, you are encouraged to contact the nearest Cincinnati Milacron representative for clarification.

**CINCINNATI
MILACRON**

Cincinnati Milacron Marketing Company
Cincinnati, Ohio 45209

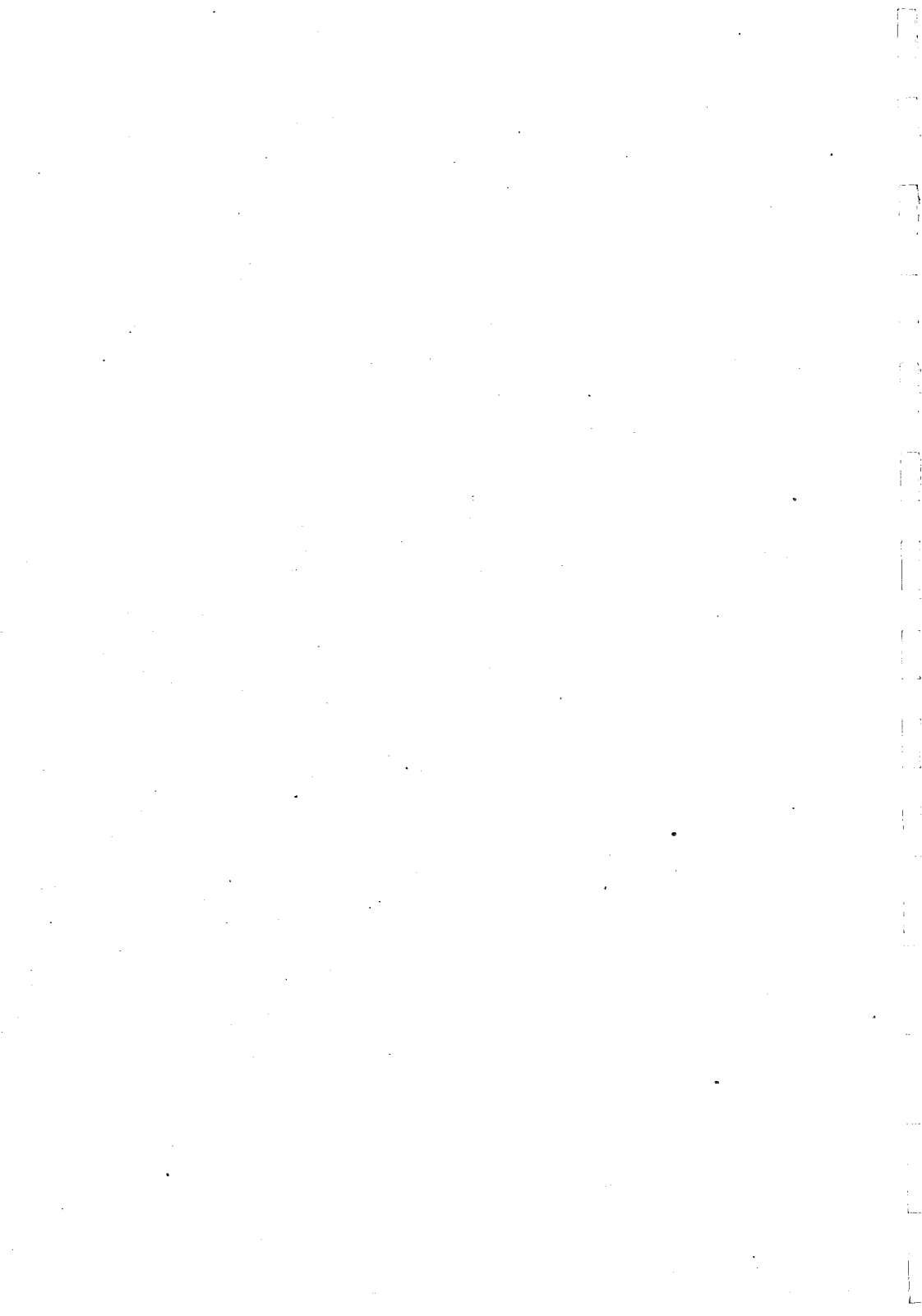

THIS booklet was made for the purpose of helping the new operator of a CINCINNATI Dial Type Miller to become familiar with his machine; and to present to the experienced operator a complete set of tables for the efficient performance of his work.

At the time of writing, the booklet was completely up to date. However, due to continual improvements in design, it is possible that descriptions contained herein may vary slightly from the machine delivered to you. This merely implies that the machine has been improved to better fulfill your requirements.

Publication No. M-875-6

**THE CINCINNATI MILLING MACHINE CO.
CINCINNATI 9, OHIO, U. S. A.**

SAFETY PRECAUTIONS

IMPORTANT

These safety precautions for this CINCINNATI MILACRON machine have been prepared to assist the operator and maintenance personnel in practicing good shop safety procedures.

Operator and maintenance personnel must read and understand these precautions completely before operating, setting up, running, or performing maintenance on the machine.

These precautions are to be used as a guide to supplement safety precautions and warnings in the following:

- a) All other manuals pertaining to the machine.
- b) Local, plant, and shop safety rules and codes.
- c) Federal and national safety laws and regulations.

See the latest edition of the OCCUPATIONAL SAFETY AND HEALTH STANDARDS, available from the DEPARTMENT OF LABOR, WASHINGTON, D.C.

WARNING

Read related safety precautions before operating this machine. Failure to follow safety instructions may result in personal injury and/or damage to machine components.

WARNING: ILLUSTRATIONS

In order to clearly show details of this machine, some covers, shields, guards, barriers, devices or doors have either been removed or shown in an "open" position. All such protective components must be installed in position before operating this machine. Failure to follow this instruction may result in personal injury and/or machine damage.

GENERAL SAFETY INSTRUCTIONS AND CONSIDERATIONS

PERSONAL SAFETY

Machine owners, operators, setup men, maintenance, and service personnel must be aware of the fact that constant day-to-day safety procedures are a vital part of their job. Accident prevention must be one of the principal objectives of the job regardless of what activity is involved.

Know and respect your machinery. Read and practice the prescribed safety and checking procedures. Make sure that everyone who works for, with, or near you fully understands and - more importantly - complies with the following safety precautions and procedures when operating this machine.

WARNING

Failure to follow instructions on this page may result in personal injury and/or damage to machine components.

Sudden movements, loud noises, horse-play, etc. must be avoided. These distractions may result in unsafe conditions for those working near the machinery.

Observe and follow safety instructions such as "NO SMOKING", "High Voltage", DANGER, etc., in your working area.

Accidents can occur that result in serious personal injury to yourself or others due to clothing and other articles becoming entangled in cutters, handwheels, levers, or moving machine elements. The following suggestions, if followed, will help you to avoid such accidents: Neckties, scarfs, gloves, loose hanging clothing, and jewelry such as watches, rings, or necklaces must not be worn around moving machinery. Restrain long hair with a cap or net. Wear gloves only when handling rough, sharp, or hot parts.

Use safety protective equipment. Wear clean approved eye or face protection. Safety-toe shoes with slip-proof soles can help you avoid injury. Keep your protective equipment in good condition.

WORK AREA SAFETY

Always keep your work area clean. Dirty work areas with such hazards as oil, debris, or water on the floor may cause someone to fall to the floor, into the machine, or onto other objects resulting in serious personal injury.

Make sure your work area is free of hazardous obstructions and be aware of protruding machine members.

Return tools and similar equipment to their proper storage place immediately after use. Keep work benches neat, orderly, and clean.

Report unsafe working conditions to your supervisor or safety department. Items such as: worn or broken flooring, ladders, and handrails, unstable or slippery platforms, or scaffolds must be reported and repaired before use. Do not use skids, workpieces, stock, machines, tote pans, and boxes as makeshift climbing aides.

TOOL SAFETY

Sharp edged cutting tools must be handled with gloves or a shop cloth. Inspect cutting tools before use and reject defective tools.

Remove hand tooling such as wrenches, measuring equipment, hammers, and other miscellaneous parts from the machine immediately after usage.

LIFTING AND CARRYING SAFETY

WARNING

Failure to follow instructions on this page may result in personal injury and/or damage to machine components.

Contact supervision if you have any questions or are not sure about the proper procedures for lifting and carrying.

Before lifting or carrying an object, determine the weight and size by referring to such things as tags, shipping data, labels, marked information, or manuals.

Use power hoists or other mechanical lifting and carrying equipment for heavy, bulky, or hard to handle objects. Use hookup methods recommended by your safety department and know the signals for safely directing a crane operator.

Never place any part of your body under a suspended load or move a suspended load over any part of another person's body. Before lifting, be certain that you have a safe spot for depositing the load. Never work on a component while it is hanging from a crane or other lifting mechanism.

If in doubt as to the size or type of lifting equipment, method, and procedures for lifting, contact Cincinnati Milacron before proceeding to lift the machine or its components.

Always inspect slings, chains, hoists, and other lifting devices prior to use. Do not use lifting devices found to be defective or questionable.

Never exceed the safety rated capacity of cranes, hoists, slings, eyebolts, and other lifting equipment. Follow standards and instructions applicable to any lifting equipment you use. (For example, ANSI Standard B18.15, available from The American National Standards Institute, Inc., 1430 Broadway, New York, New York 10018, contains information concerning safe lifting loads for different size eyebolts, for various angles of lift and application instructions for safe use of eyebolts.)

Before inserting an eyebolt, be certain that both the eyebolt and the hold have the same size and type threads. To attain safe working loads, at least 90% of the threaded portion of a standard forged eyebolt must be engaged.

INSTALLATION AND RELOCATION SAFETY

Before lifting the machine, consult the machine manual or Cincinnati Milacron for proper methods and procedures.

An electrician must read and understand the electrical schematics prior to connecting the machine to the power source. After connecting the machine, test all aspects of the electrical system for proper functioning. Always make sure the machine is grounded properly. Be certain that all exposed electrical systems are covered properly. Place all selector switches in their OFF or neutral (disengaged) position. The doors of the main electrical cabinet must be closed and the main disconnect switch must be in the OFF position after the power source connection is complete.

WARNING

Failure to follow instructions on this page may result in personal injury and/or damage to machine components.

Always lock the main disconnect device in the OFF position if the machine is left unattended. Never bypass or wire around safety devices.

When the machine is installed, be sure that the motors rotate in the proper indicated direction.

SETUP AND OPERATION SAFETY

Read and understand all the safety instructions before setting up, operating, or servicing this machine. Assign only qualified personnel, instructed in safety and all machine functions, to operate or service this machine.

Operators and maintenance personnel must carefully read, understand, and fully comply with all machine mounted warning and instruction plates. Do not paint over, alter, or deface these plates or remove them from the machine. Replace all plates which become illegible. Replacement plates can be purchased from Cincinnati Milacron.

Safety guards, shields, barriers, covers, and protective devices must be connected or in place before operating the machine.

Safety disengagements or interlocks provided on handwheels must be in place before operation.

When setting up or adjusting a workpiece or fixture, be certain it is a safe distance away from the cutting tool. Always retract the workpiece a safe distance from the cutting tool when loading and unloading.

The spindle must be stopped before adjusting the coolant discharge nozzle.

Never brake or slow down moving machinery with your hand or with some makeshift device. Never use machine power to remove a nut from any shaft. The spindle and slides must be stopped when measuring workpieces, changing tools, or removing chips and grit. Remove chips and grit with a chip rake or brush, not with your hands.

Keep all parts of your body off the machine table, table edge, out of the path of moving units, trip dogs, trip plungers, and out of the "machining area" during machining operations. Never lean on a machine or reach over or through a machine — you can become entangled in tooling and other moving elements or you may accidentally activate start buttons, feed controls, rapid traverse controls, power work holding control, or similar devices.

During operation, be attentive to the machining process. Excessive vibration, unusual sounds, etc., can indicate problems requiring your immediate attention. Watch for conditions such as packed chips or grit which can cause breakage of tooling or machine elements.

Shut off power to your machine when you leave the operating area or at the end of your work period; never leave a machine running unattended. Turn the master disconnect device to the OFF position before cleaning the machine at the end of the working day or when guards or covers are removed that expose hazardous areas.

MAINTENANCE SAFETY

WARNING

Failure to follow instructions on this page may result in personal injury and/or damage to machine components.

Do not attempt to perform maintenance on this machine until you read and understand all the safety instructions.

Assign only qualified service or maintenance personnel to perform maintenance and repair work on this machine. Consult the service manual before attempting any service or repair work and when in doubt contact Cincinnati Milacron. Use only Cincinnati Milacron replacement parts; others may impair the safety of the machine. Before performing maintenance or service work, Warning or Danger signs must be placed conspicuously about the machine. Before detaching counterweights or driving mechanisms, vertical sliding members must be blocked properly. See the Service Manual for proper dismantling procedures.

DANGER: HIGH VOLTAGE

Before working on any electrical circuits, turn the machine Main Disconnect Device "OFF" and lock it.

Unless expressly stated in applicable Cincinnati Milacron documentation or by the appropriate Cincinnati Milacron Field Service Representative, do NOT work with electrical power "ON". If such express statement or advice exists, working with electrical power "ON" should be performed by a Cincinnati Milacron Field Service Representative. The customer and subsequent transferees must determine that any other person performing work with electrical power "ON" is trained and technically qualified.

FAILURE TO FOLLOW THIS INSTRUCTION MAY RESULT IN DEATH OR SERIOUS PERSONAL SHOCK INJURY.

O-GS-2 (3/83)

Before removing or opening any electrical enclosure, cover, plate, or door, be sure that the main disconnect switch is in the OFF position. If any tool is required to remove a guard, cover, bracket, or any basic part of this machine, place the main disconnect switch in the OFF position, lock it in the OFF position. If possible, post a sign at the disconnect switch indicating that maintenance is being performed.

Whenever maintenance is to be performed in an area away from the disconnect and the disconnect is not locked, tag all start button stations with a "DO NOT START" tag. Adequate precautions, such as locks on circuit breakers, warning notices, or other equally effective means must be taken to prevent electrical equipment from being electrically activated when maintenance work is being performed.

Before attempting to adjust, repair, or perform maintenance on electrical circuits connected with yellow wires, first find the source of power, turn it off; and lock it in the OFF position. Machine tool interlock control circuits connected with yellow wires are powered from a source away from the machine and carry voltage even when the machine's main disconnect device is turned to the OFF position.

When removing electrical equipment, place number or labelled tags on those wires not marked. If wiring is replaced, be sure it is of the same type, length, size, and has the same load carrying capacity.

Close and securely fasten all guards, shields, covers, plates, or doors before power is reconnected.

An electrical technician must analyze the electrical system to determine the possible use of power retaining devices such as capacitors. Such power retaining devices must be disconnected, discharged or made safe before maintenance is performed.

Working space around electrical equipment must be clear of obstructions. Provide adequate illumination to allow for proper operation and maintenance.

WARNING

Failure to follow instructions on this page may result in personal injury and/or damage to machine components.

PATENT NOTICE

The machines and attachments illustrated and described in this booklet are manufactured under and protected by issued and pending United States and Foreign Patents.

• • •

The design and specifications of these machines are subject to change without notice.

A SUGGESTION

To assure this booklet being available when it is needed, we suggest that it be placed in the tool crib and issued by tool check only.

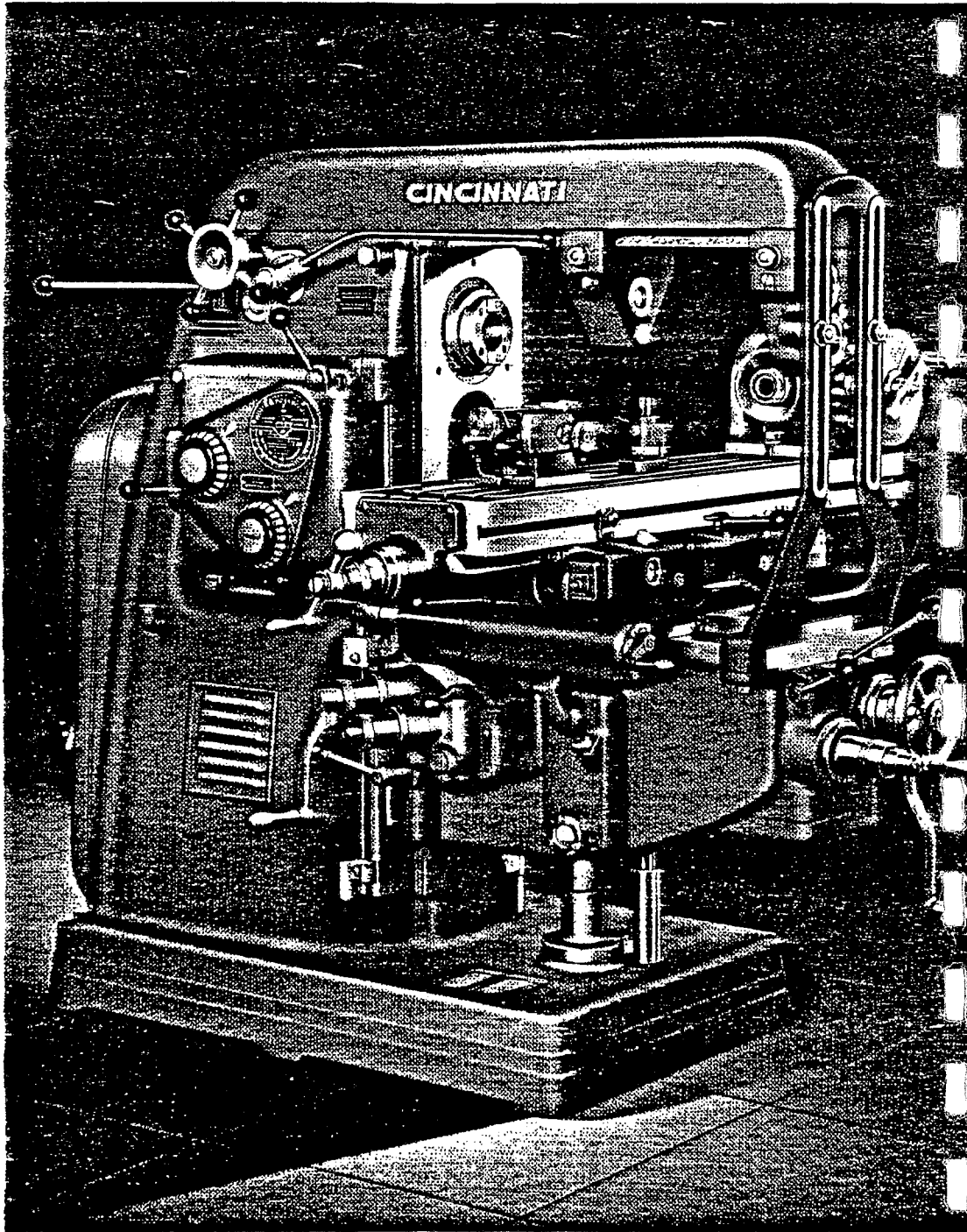

Cincinnati No. 2 Universal High Speed Dial Type Milling Machine

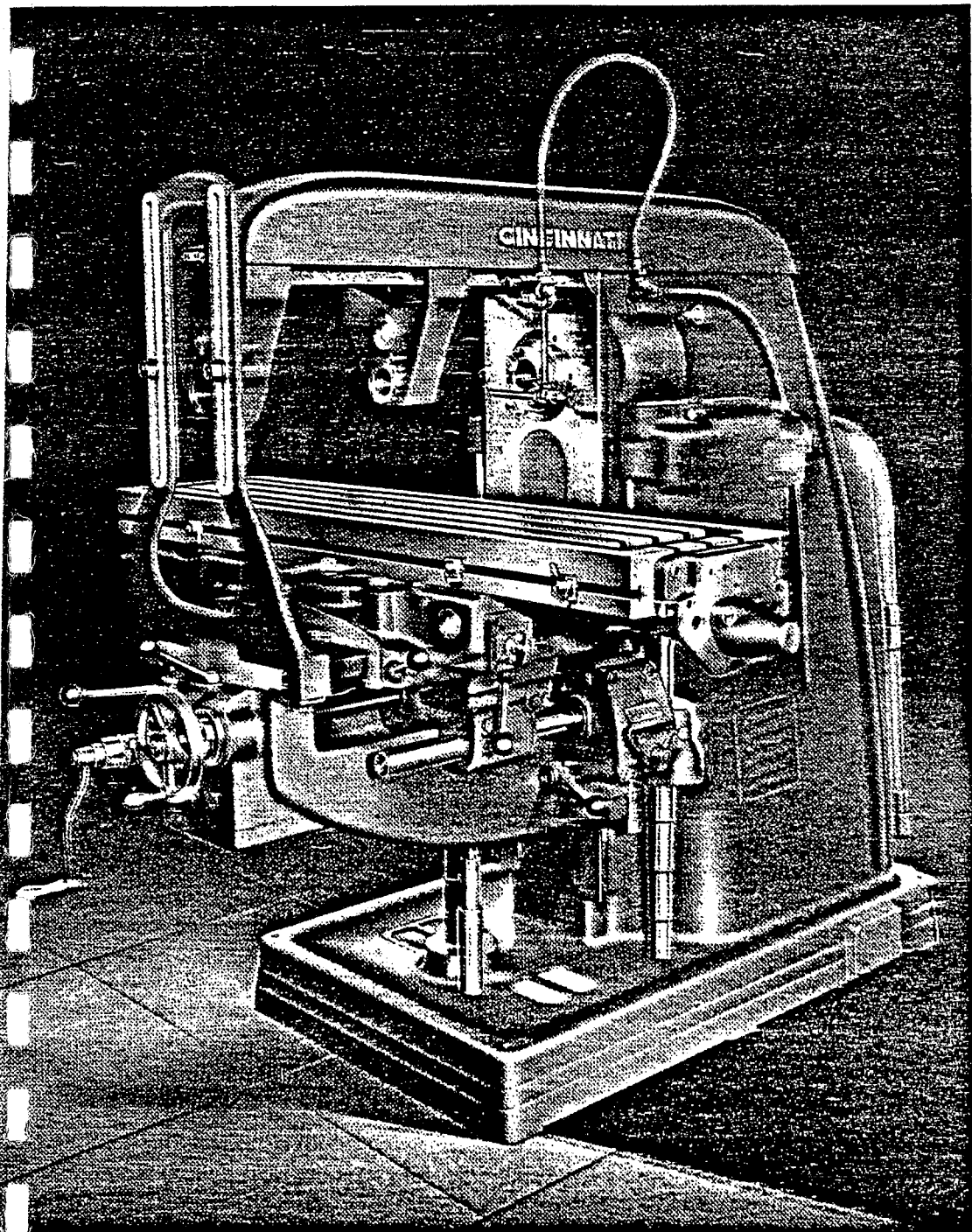

Cincinnati No. 3 Plain High Speed Dial Type Milling Machine

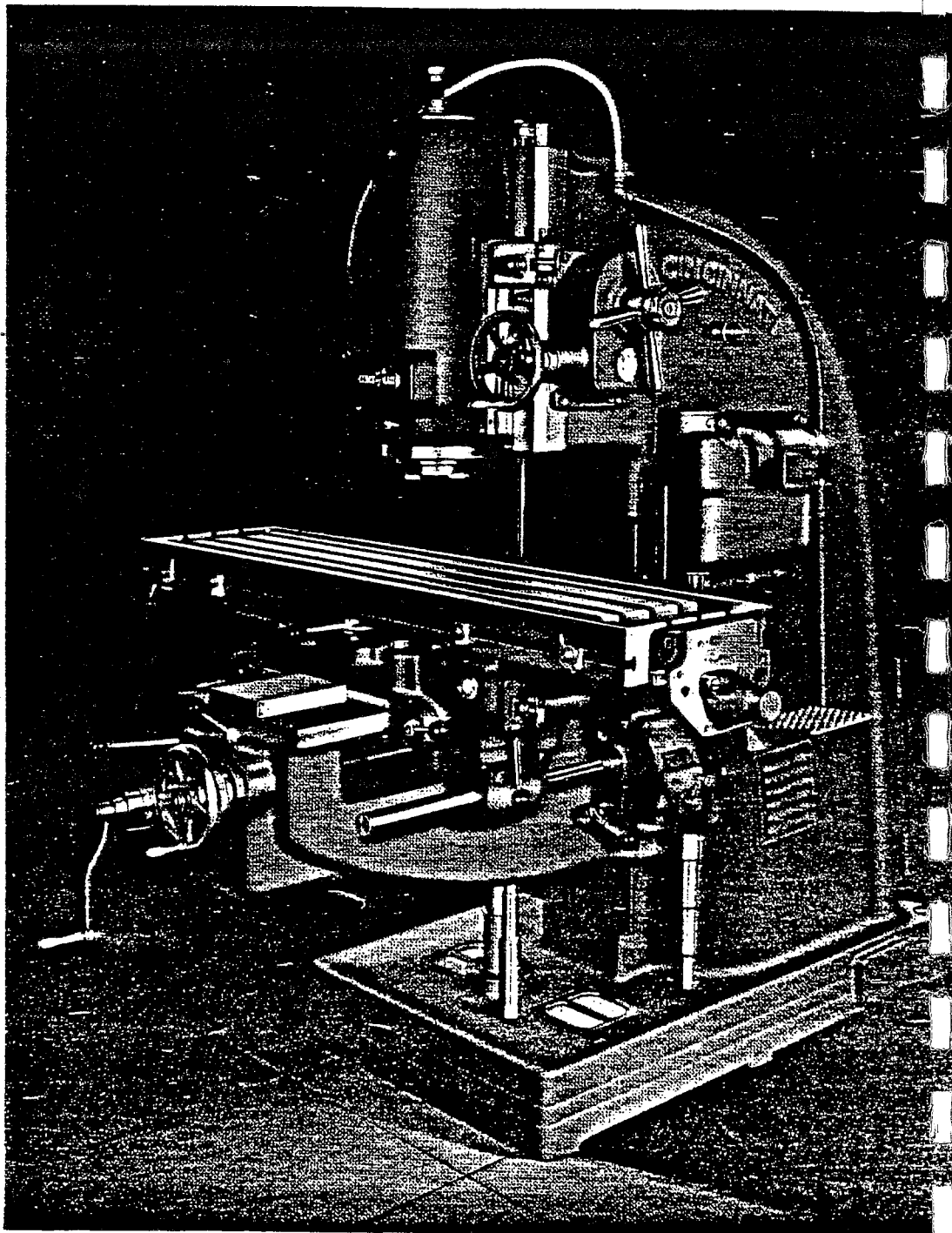

Cincinnati No. 3 Vertical High Speed Dial Type Milling Machine

CONTENTS

	Page
Specifications	9-15
Standard Equipment Supplied with the Machine	16
Installation	17-18
Starting the Machine for the First Time	19
Lubrication	20-21
Functional Diagram	22
Operating Instructions	23-29
Setting Up the Machine	30-34
Cutting Fluid	35
Cleaning the Coolant Reservoir	36
Adjustments	37-44
Safety Precautions	45
Dividing Head	46-57
The Wide Range Divider	58-60
Milling Cams	61
Backlash Eliminator	62-65
Accessories and Attachments	66-89
Method of Calculating Machining Time	90-93
Dividing Head Tables	95-121
Ordering Repair Parts	122
Alphabetical Index	124-128
List of Agents	128

SERIAL NUMBER

The serial number will be found stamped in two places: Horizontal Machines, on the face of the column near the spindle, and front of the table near the right hand end. Vertical Machines, top of the scraped bearing for the knee and front of the table near the right hand end.

MACHINE SPECIFICATIONS
(Model ER)

	MEDIUM SPEED AND HIGH SPEED DIAL TYPE MILLERS		
	No. 2	No. 3	No. 4
Table			
Working surface.....	52 $\frac{1}{2}$ x12 $\frac{1}{4}$	62 $\frac{1}{2}$ x15 $\frac{1}{4}$	78 $\frac{1}{2}$ x16 $\frac{1}{4}$
Size over all.....	52 $\frac{1}{2}$ x12 $\frac{1}{4}$	62 $\frac{1}{2}$ x15 $\frac{1}{4}$	78 $\frac{1}{2}$ x16 $\frac{1}{4}$
T-slots.....	Three- $\frac{1}{2}$	Three- $\frac{1}{2}$	Three- $\frac{1}{2}$
Distance between T-slots.....	2 $\frac{1}{8}$	3 $\frac{1}{4}$	3 $\frac{1}{4}$
Swing of table (Universal only).....	45°	47°	49°
Range			
Longitudinal travel.....	28	34	42
Cross travel { Plain and Universal.....	10	12	14
{ Vertical.....	12	16	16
Vertical travel { Plain.....	19	20	20
{ Universal.....	18	19	19
{ Vertical.....	13	16	16
Horizontal Machines Only			
Max. distance, center of spindle to top of table (Plain)...	19 $\frac{1}{8}$	20 $\frac{1}{8}$	20 $\frac{1}{8}$
Min. distance, center of spindle to top of table (Plain)...	0	0	0
Max. distance, center of spindle to top of table (Univ.)...	18 $\frac{1}{8}$	19 $\frac{1}{8}$	19 $\frac{1}{8}$
Min. distance, center of spindle to top of table (Univ.)...	0	0	0
Full width between column and braces.....	30 $\frac{1}{4}$	33 $\frac{1}{2}$	38 $\frac{1}{4}$
Center of spindle to bottom of overarm.....	6 $\frac{1}{8}$	7 $\frac{3}{8}$	7 $\frac{3}{8}$
Vertical Machines Only			
Max. distance, end of spindle to top of table.....	18	22	22
Throat distance, center of spindle to column.....	14	18	18
Standard Spindle End, No. 50			
Flange.....	5 $\frac{1}{8}$ diam.	5 $\frac{1}{8}$ diam.	5 $\frac{1}{8}$ diam.
Taper hole.....	{ 2 $\frac{1}{4}$ diameter large end 3 $\frac{1}{2}$ per foot	{ 2 $\frac{1}{4}$ diameter large end 3 $\frac{1}{2}$ per foot	{ 2 $\frac{1}{4}$ diameter large end 3 $\frac{1}{2}$ per foot
Net Weights, Pounds (Approximate)			
Medium Speed { Plain.....	6,250	8,380	9,050
{ Universal.....	6,600	9,000	10,000
{ Vertical.....	7,050	9,200	9,850
High Speed { Plain.....	6,350	8,480	9,150
{ Universal.....	6,700	9,100	10,100
{ Vertical.....	7,100	9,300	9,950

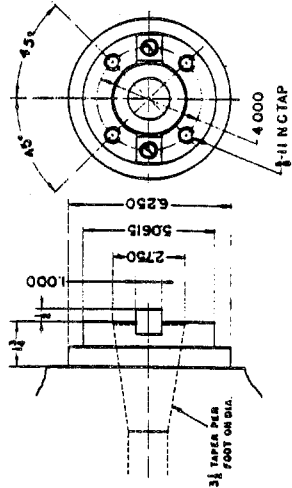
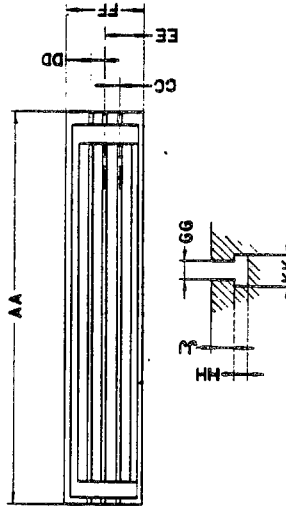
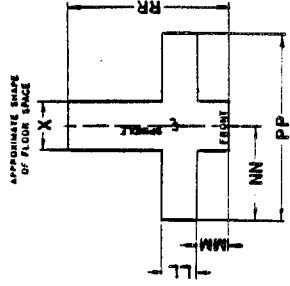
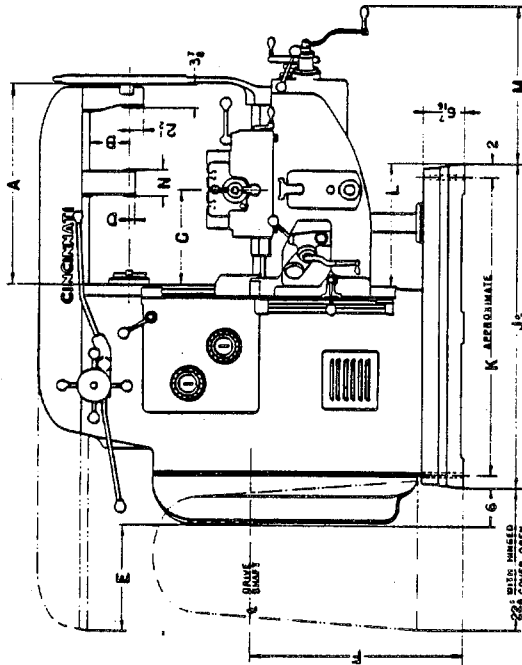
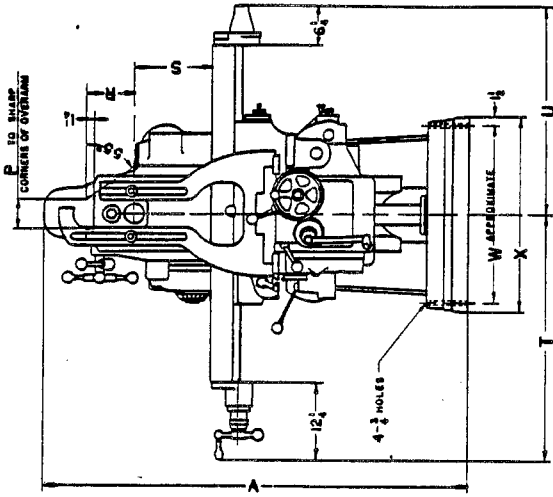

FLOOR PLAN

TABLE AND T-SLOT

SPINDLE NOSE

Figure 1
Dimensional Drawing—Plain Machines (See page 11 for table of dimensions)

PC-336

TABLE OF DIMENSIONS—PLAIN MACHINES

	Size of Machine		
	No. 2	No. 3	No. 4
A	$30\frac{1}{4}$	$33\frac{1}{2}$	$38\frac{1}{4}$
B	$6\frac{1}{8}$	$7\frac{3}{8}$	$7\frac{3}{8}$
C	Min.	$9\frac{1}{16}$	$10\frac{1}{16}$
	Max.	$19\frac{7}{8}$	$23\frac{5}{16}$
D	$7\frac{1}{8}$	$1\frac{1}{16}$	$1\frac{1}{16}$
E	$16\frac{1}{2}$	$18\frac{3}{4}$	$22\frac{1}{2}$
F	$32\frac{1}{16}$	$33\frac{1}{16}$	$33\frac{1}{16}$
J	$50\frac{1}{4}$	59	59
K	$46\frac{1}{4}$	55	55
L	19	$20\frac{3}{4}$	$20\frac{3}{4}$
M	$26\frac{7}{16}$	$27\frac{1}{2}$	$32\frac{5}{16}$
N	4	$4\frac{5}{16}$	$4\frac{5}{16}$
P	$4\frac{1}{2}$	6	6
R	$7\frac{3}{8}$	$8\frac{5}{8}$	$8\frac{5}{8}$
S	Min.	0	0
	Max.	$19\frac{3}{16}$	$20\frac{7}{16}$
T	Min.	$22\frac{1}{16}$	$23\frac{1}{4}$
	Max.	$50\frac{3}{16}$	$57\frac{3}{4}$
U	Min.	$20\frac{5}{8}$	$23\frac{1}{4}$
	Max.	$49\frac{1}{8}$	$57\frac{3}{4}$
V	$64\frac{1}{16}$	$70\frac{5}{16}$	$70\frac{1}{16}$
W	$27\frac{1}{2}$	$29\frac{1}{2}$	$29\frac{1}{2}$
X	$30\frac{1}{2}$	$32\frac{1}{2}$	$32\frac{1}{2}$
AA	$52\frac{1}{16}$	$62\frac{1}{2}$	$78\frac{1}{2}$
CC	$2\frac{5}{16}$	$3\frac{1}{4}$	$3\frac{1}{4}$
DD	$2\frac{5}{16}$	$3\frac{1}{4}$	$3\frac{1}{4}$
EE	6	$7\frac{1}{2}$	8
FF	$12\frac{1}{4}$	$15\frac{1}{4}$	$16\frac{1}{4}$
GG	$\frac{11}{16}$	$\frac{1}{16}$	$\frac{1}{16}$
HH	$\frac{31}{64}$	$\frac{5}{8}$	$\frac{5}{8}$
JJ	$\frac{7}{8}$	1	1
KK	$1\frac{1}{4}$	$1\frac{1}{16}$	$1\frac{1}{16}$
LL	$22\frac{1}{16}$	$27\frac{3}{4}$	$30\frac{7}{8}$
MM	$19\frac{9}{16}$	$17\frac{7}{16}$	$19\frac{1}{16}$
NN	$50\frac{9}{16}$	$57\frac{3}{4}$	$69\frac{3}{4}$
PP	$99\frac{1}{16}$	$115\frac{1}{2}$	$139\frac{1}{2}$
RR	$99\frac{1}{16}$	$111\frac{1}{4}$	$119\frac{7}{8}$

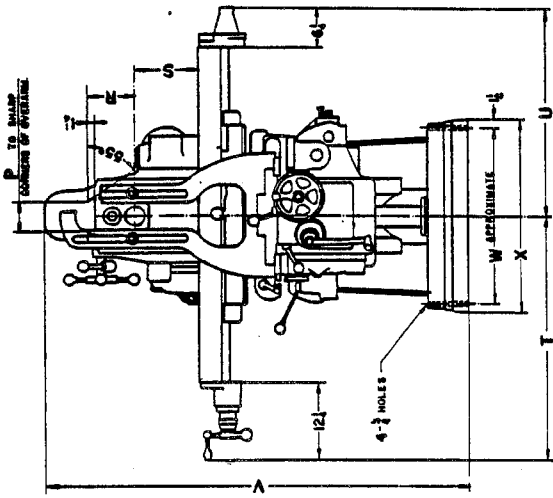

PC-317

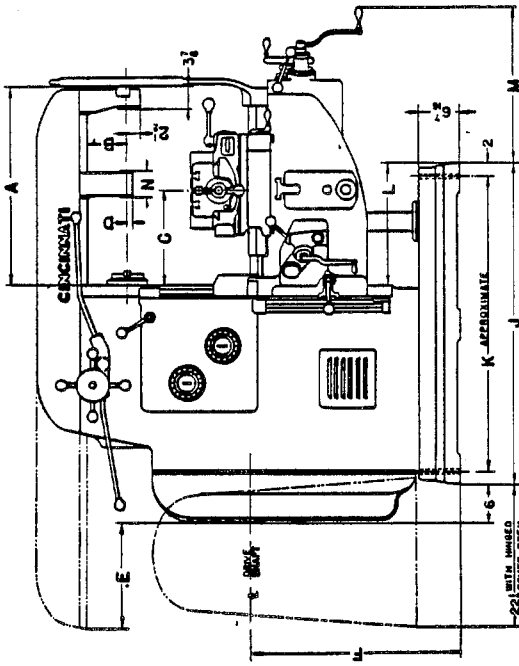

[12]

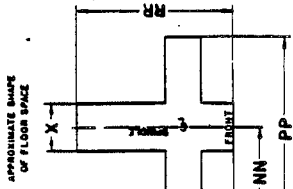

FLOOR PLAN

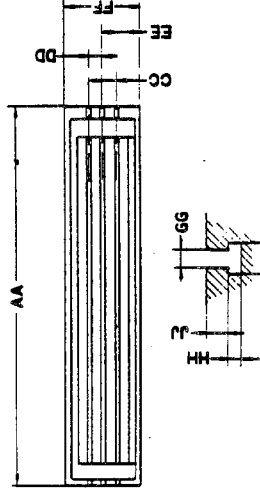
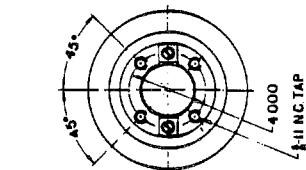

TABLE AND T-SLOT



SPINDLE NOSE

STANDARD FLANGED END WITH NO. 30 SERIES TAPER

3/16" TAPER PER FOOT ON DIA

PC-318

Figure 2 Dimensional Drawing—Universal Machines (See page 13 for table of dimensions)

TABLE OF DIMENSIONS—UNIVERSAL MACHINES

	Size of Machine		
	No. 2	No. 3	No. 4
A	30 $\frac{1}{4}$	33 $\frac{1}{2}$	38 $\frac{1}{4}$
B	6 $\frac{1}{8}$	7 $\frac{3}{8}$	7 $\frac{3}{8}$
C	Min.	11 $\frac{1}{16}$	11 $\frac{3}{16}$
	Max.	23 $\frac{5}{16}$	25 $\frac{7}{8}$
D	7 $\frac{7}{8}$	11 $\frac{1}{16}$	11 $\frac{1}{16}$
E	16 $\frac{1}{2}$	18 $\frac{3}{4}$	22 $\frac{1}{2}$
F	32 $\frac{7}{16}$	33 $\frac{11}{16}$	33 $\frac{11}{16}$
J	50 $\frac{1}{4}$	59	59
K	46 $\frac{1}{4}$	55	55
L	19	20 $\frac{3}{4}$	20 $\frac{3}{4}$
M	26 $\frac{7}{16}$	27 $\frac{1}{2}$	32 $\frac{5}{16}$
N	4	4 $\frac{5}{16}$	4 $\frac{5}{16}$
P	4 $\frac{1}{2}$	6	6
R	7 $\frac{3}{8}$	8 $\frac{5}{8}$	8 $\frac{5}{8}$
S	Min.	0	0
	Max.	18 $\frac{3}{16}$	19 $\frac{7}{16}$
T	Min.	22 $\frac{7}{16}$	23 $\frac{1}{4}$
	Max.	50 $\frac{15}{16}$	57 $\frac{3}{4}$
U	Min.	20 $\frac{1}{4}$	23 $\frac{1}{4}$
	Max.	48 $\frac{3}{4}$	57 $\frac{3}{4}$
V	64 $\frac{11}{16}$	70 $\frac{5}{16}$	70 $\frac{11}{16}$
W	27 $\frac{1}{2}$	29 $\frac{1}{2}$	29 $\frac{1}{2}$
X	30 $\frac{1}{2}$	32 $\frac{1}{2}$	32 $\frac{1}{2}$
AA	52 $\frac{11}{16}$	62 $\frac{1}{2}$	78 $\frac{1}{2}$
CC	2 $\frac{5}{16}$	3 $\frac{1}{4}$	3 $\frac{1}{4}$
DD	2 $\frac{1}{16}$	3 $\frac{1}{4}$	3 $\frac{1}{4}$
EE	6	7 $\frac{1}{2}$	8
FF	12 $\frac{1}{4}$	15 $\frac{1}{4}$	16 $\frac{1}{4}$
GG	1 $\frac{1}{16}$	1 $\frac{1}{16}$	1 $\frac{1}{16}$
HH	2 $\frac{1}{4}$	2 $\frac{5}{8}$	2 $\frac{5}{8}$
JJ	7 $\frac{7}{8}$	1	1
KK	1 $\frac{1}{4}$	1 $\frac{15}{32}$	1 $\frac{15}{32}$
LL	22 $\frac{5}{8}$	27 $\frac{1}{2}$	30 $\frac{3}{16}$
MM	19 $\frac{3}{16}$	17 $\frac{7}{16}$	19 $\frac{1}{16}$
NN	50 $\frac{11}{16}$	57 $\frac{3}{4}$	69 $\frac{3}{4}$
PP	99 $\frac{11}{16}$	115 $\frac{1}{2}$	139 $\frac{1}{2}$
RR	99 $\frac{1}{16}$	111 $\frac{1}{4}$	119 $\frac{7}{8}$

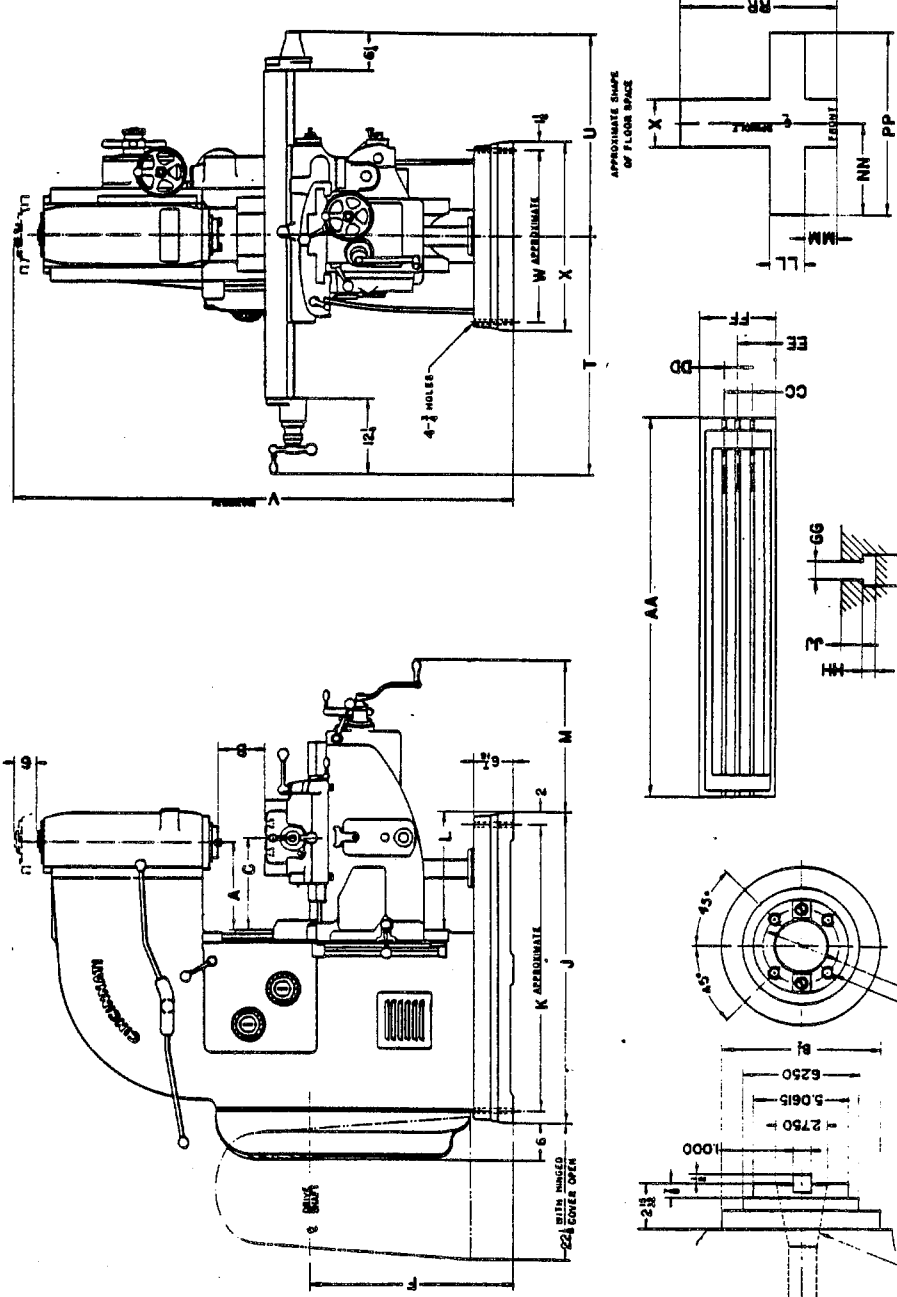

FLOOR PLAN

TABLE AND T-SLOT

SPINDLE NOSE

PC-118

Figure 3
 Dimensions of Machine
 See page 5 for details

TABLE OF DIMENSIONS—VERTICAL MACHINES

	Size of Machine			
	No. 2	No. 3	No. 4	
A	14	18	18	
B	Min.	0	0	
	*Max	$18\frac{3}{4}$	$22\frac{1}{8}$	$22\frac{1}{8}$
C	Min.	$9\frac{3}{16}$	$10\frac{1}{8}$	$11\frac{1}{4}$
	Max.	$21\frac{1}{2}$	$27\frac{1}{8}$	$27\frac{1}{2}$
F	$33\frac{1}{4}$	$38\frac{3}{8}$	$38\frac{3}{8}$	
J	$50\frac{1}{4}$	59	59	
K	$46\frac{1}{4}$	55	55	
L	19	$20\frac{3}{4}$	$20\frac{3}{4}$	
M	$26\frac{7}{16}$	$30\frac{3}{16}$	$30\frac{3}{16}$	
T	Min.	$22\frac{1}{16}$	$27\frac{1}{4}$	$27\frac{1}{4}$
	Max.	$50\frac{3}{16}$	$57\frac{3}{4}$	$69\frac{3}{4}$
U	Min.	$20\frac{5}{8}$	$23\frac{1}{4}$	$27\frac{1}{4}$
	Max	$49\frac{1}{8}$	$57\frac{3}{4}$	$69\frac{3}{4}$
V	$78\frac{1}{8}$	$85\frac{3}{4}$	$85\frac{3}{4}$	
W	$27\frac{1}{2}$	$29\frac{1}{2}$	$29\frac{1}{2}$	
X	$30\frac{1}{2}$	$32\frac{1}{2}$	$32\frac{1}{2}$	
AA	$52\frac{1}{16}$	$62\frac{1}{2}$	$78\frac{1}{2}$	
CC	$2\frac{3}{16}$	$3\frac{1}{4}$	$3\frac{1}{4}$	
DD	$2\frac{3}{16}$	$3\frac{1}{4}$	$3\frac{1}{4}$	
EE	6	$7\frac{1}{2}$	8	
FF	$12\frac{1}{4}$	$15\frac{1}{4}$	$16\frac{1}{4}$	
GG	$\frac{11}{16}$	$\frac{13}{16}$	$\frac{13}{16}$	
HH	$\frac{31}{64}$	$\frac{5}{8}$	$\frac{5}{8}$	
JJ	$\frac{7}{8}$	1	1	
KK	$1\frac{1}{4}$	$1\frac{1}{2}$	$1\frac{1}{2}$	
LL	$24\frac{9}{16}$	$31\frac{9}{16}$	$32\frac{1}{2}$	
MM	$17\frac{15}{16}$	$16\frac{7}{16}$	$15\frac{9}{16}$	
NN	$50\frac{9}{16}$	$57\frac{3}{4}$	$69\frac{3}{4}$	
PP	$99\frac{11}{16}$	$115\frac{1}{2}$	$139\frac{1}{2}$	
RR	$98\frac{3}{4}$	$111\frac{3}{8}$	$111\frac{3}{8}$	

*Note—Maximum dimension "B" is with head in extreme up position and knee in extreme down position.

STANDARD EQUIPMENT

Supplied with the Machine

Plain Machines:

Arbor Supports: No. 2 Millers—one Style "B" with $2\frac{1}{8}$ " adjustable arbor bushing and provided with lug for brace—one Style "A" with adjustable arbor bushing for pilot end arbors. Nos. 3 and 4 Millers—one Style "B" with $2\frac{1}{8}$ " adjustable arbor bushing without lug for brace—one style "B" with $2\frac{1}{8}$ " adjustable arbor bushing and provided with lug for brace.

Adjustable Arbor Tightening Rod.

Arbor Support Bushing Adapter M-01 (includes adjustable bushing, nut, washer, and screw) for Style "A" arbors and for Nos. 3 and 4 Machines only.

Wrenches.

Coolant Pump (Gear Driven).

Overarm Brace.

Universal Machines:

Arbor Supports: No. 2 Millers—one Style "B" with $2\frac{1}{8}$ " adjustable arbor bushing and provided with lug for brace—one Style "A" with adjustable arbor bushing for pilot end arbors. Nos. 3 and 4 Millers—one Style "B" with $2\frac{1}{8}$ " adjustable arbor bushing without lug for brace—one Style "B" with $2\frac{1}{8}$ " adjustable arbor bushing and provided with lug for brace.

Adjustable Arbor Tightening Rod.

Arbor Support Bushing Adapter M-01 (includes adjustable bushing, nut, washer and screw) for Style "A" arbors and for Nos. 3 and 4 Machines only.

Standard Universal Dividing Head Equipment, including tailstock with 2-point adjustable center; steady rest; one plate for indexing through 40 to 1 reduction—all numbers up to and including 60, all even numbers and those divisible by 5 up to 120, and many beyond; one plate for direct indexing; one center for headstock; and provision for connecting head to enclosed driving mechanism segment. Sizes (nominal swing): 10" for No. 2 Machine; 12" for No. 3 Machine; 14" for No. 4 Machine.

Enclosed Driving Mechanism Segment, including change gears for spiral milling, leads range from $2\frac{1}{2}$ " to 100" (only) for Standard Universal Dividing Heads.

Wrenches.

Coolant Pump (Gear Driven).

Overarm Brace.

Vertical Machines:

Adjustable Arbor Tightening Rod.

Wrenches.

Coolant Pump (Gear Driven).

INSTALLATION INSTRUCTIONS

Complete erecting instructions are listed on a separate sheet, entitled "General Installation Instructions", packed with the machine. They are repeated briefly in this booklet for your information.

Assembling the Table to the Machine. If the machine table has been removed for convenience in shipping, it may be replaced in the following manner:

1. Wash the bearings on the saddle and table perfectly clean. Cover the saddle with a liberal supply of oil.
2. Insert the table locking shoes in the front of the saddle and follow up with the two hexagon head set screws.
3. Insert table from the left side of the machine, as you stand in front of the machine.
4. Insert the table gib between the saddle and the table and adjust the gib screw so that the table will have no side play. It is safe to adjust the gib tightly so that four men cannot pull the table, and then back off the gib slightly until four men can pull it easily.
5. Insert the lead screw from the right of the machine, and turn the screw into the nut until the apron on the lead screw is tight against the table. Be sure the dowel pins in the apron match with the pin holes in the end of the table. Insert and tighten the four screws. (See Fig. 26, page 40)
6. Attach the left hand apron to the front end of the table. Adjust the adjusting nut on the lead screw to take up the end play in the lead screw. Tighten the hexagon head lock screw in the adjusting nut.
7. Place the clutch, dial, collar and spring, ball crank and screw in the end of the lead screw to keep the ball crank in place.

Note: The bored hole in the saddle paralleling the lead screw is provided for the drive shaft for the circular milling attachment. This drive shaft is supplied as regular equipment with the power feed Circular Milling Attachment only.

Lifting the Machine. The machine may be lifted by a crane with a rope or cable sling around the overarm. If a wire cable is used, be sure to protect the dovetail bearings with wood blocks. Tighten the overarm clamping bolts before lifting.

Foundation. Special foundations for CINCINNATI Dial Type Milling Machines are not required. Any substantial floor, wood or concrete, fairly flat, and sufficiently heavy to withstand the weight of the machine, will be satisfactory. See specifications page 9, for weights and dimensions.

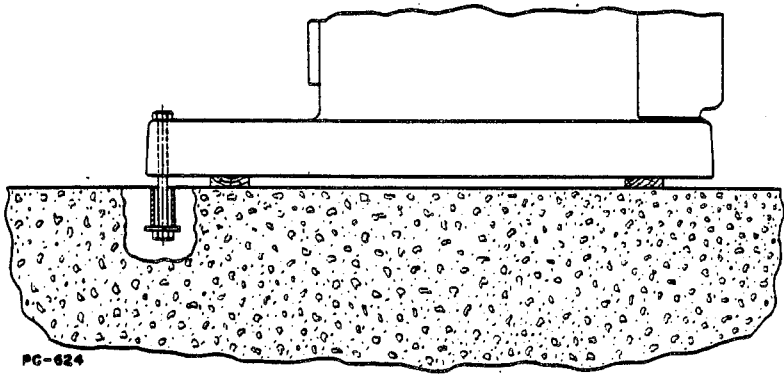

Figure 4
Bolting the Machine to a Concrete Floor

Bolting the Machine to the Floor. When preparing for this operation, notice that center distances of bolt holes, given on the data sheet accompanying the machine, are approximated. If the floor is concrete, drill the bolt holes about 6" in diameter. Insert the hold-down bolt through a 1½" pipe, as illustrated in Fig. 4, and fill the pipe with dry sand. Lower the machine on two 1" thick boards, and engage the nuts on two or three threads of the bolts. Fill the holes around the pipe with quick drying cement, thin enough to flow easily. When cement is dry, remove boards, level machine and tighten hold-down nuts.

Leveling. After the machine has been moved to its proper location, it must be carefully leveled. Use an accurate micrometer level for the operation. A carpenter's level or the bulb in a machinist's combination square is not good enough. Drive steel wedges under the corners of the base until the table is level in both directions. Then drive additional wedges under the base to evenly distribute the weight of the machine, and recheck for level. It is necessary, of course, that the machine table and leveling instrument be absolutely clean and free of burrs to obtain the most accurate results.

The sliding head of a vertical miller is balanced by counterweights inside the machine column. These weights are held in position during shipment by means of two screws, one on each side of the column, and identified by instruction tags tied to them. Remove the screws and plug the holes with the pipe plugs provided for that purpose.

STARTING THE MACHINE FOR THE FIRST TIME

After the machine has been properly installed, wash off the slushing oil and dirt accumulated in transit with naphtha or a similar solvent of grease. Then fill all oiling stations with the grade of lubricant specified (See page 21.)

Before assembling the V-belts or chain to the motor, turn it over by hand a few times to be sure that it rotates freely, and that no foreign materials have fallen into the motor during shipment or while being unpacked.

Start the motor only, and immediately notice the direction of rotation of the driving pulley at the rear of the machine. To start the motor with the hinged belt guard cover open, the safety switch, Fig. 32, page 45, must be held in contact by hand while the regular starting button is pushed. The motor must rotate clockwise, as indicated by the brass plate (Fig. 5) attached to the pulley. Lever "C", Fig. 15, page 30, should be in its disengaged position when the machine is received. The spindle will not rotate until this lever is moved to either its "Right" or "Left" engaged position. Run the machine for a half hour or so to insure a protective film of oil over all bearings, and apply oil frequently during this period. Do not fill the reservoirs while the machine is running.

Note in particular the saddle-table oil-shot lubrication system, station 7, Fig. 7. The oil level in this reservoir must be above the low limit at all times. If the oil is completely exhausted, air will get into the system, and it will be necessary to operate the pump several times to expel the air.

Pull the plunger out the full length of its stroke and allow it to return itself. *Do not push.*



Figure 5
Main Drive Pulley Must
Rotate in This Direction
Viewed From Rear of
Machine

Filling the Column Oil Reservoir. When necessary to fill the column oil reservoir, or add an appreciable amount, the best procedure is to remove the small rectangular cover attached to the "feed box" casting on the right hand side of the machine. (This is the rapid traverse clutch adjustment cover, page 39.) Oil may then be pumped or poured into the column rapidly. If poured from a container without a spout, a sheet metal chute can readily be fabricated to fit the opening. While one man is pouring or pumping the oil into the reservoir, another man should watch the oil level in the elbow, No. 10, on the left hand side of the machine. As soon as the oil reaches the bottom of the threads in the elbow, it is at the proper working level. *Use oil specified in the table, page 21.*

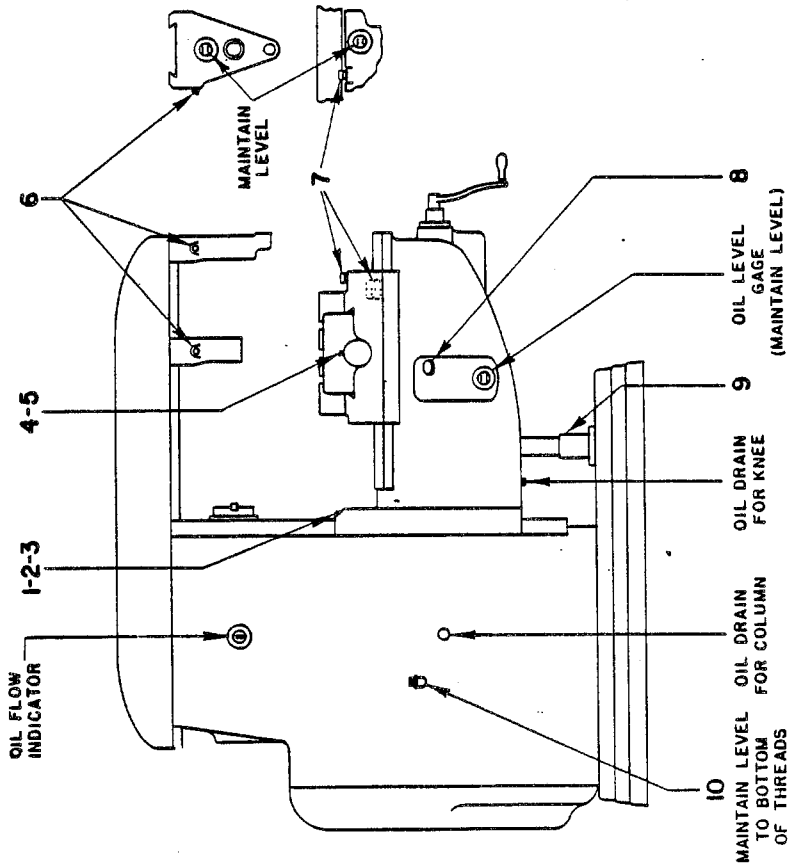

Figure 7
Lubrication Chart for Horizontal Machines

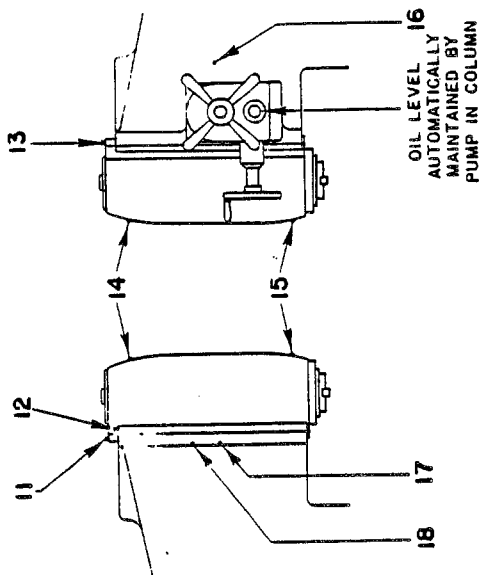

Figure 6
Lubrication Chart for Head of Vertical Machines
(Instructions for Part of Vertical Machine Not Shown are Same as for Horizontals—Fig. 7)

PC-100

LUBRICATING INSTRUCTIONS AND SPECIFICATIONS — All Styles of Dial Type Millers

When to Oil	Station Number	Parts Lubricated	Lubricating Instructions	Specifications of Lubricant
Once a Day	1, 2, 3, 4, 5, 11, 12, 13	Flat sliding bearings and lead screw bearings	Oil with bench oiler	P-31 Medium machine mineral oil. Viscosity 190 to 210 seconds Saybolt at 100° F.
Once a Week	14, 15, 16, 17, 18	Spindle and bevel gear bearings (Verticals only)	Apply one shot of grease with grease gun. Do not apply too much grease to stations 15 and 16, or bearings may overheat. Lubricate other stations (14, 17 and 18) liberally.	P-43 Medium sponge short fibre grease, Sodium soap base. (Such as Superla 2X Grease, Standard Oil Co. of Indiana)
When level recedes to low limit on gage	6	Arbor bearing collar	Oil feeds continuously. Keep level above low limit on gage <i>Automatic Lubrication.</i> 1/2 pint required	Same as Specification P-31 above Also see note.†
When level recedes to low limit on gage	7	Saddle parts and knee bearings of the saddle	Keep reservoir filled to line on gage. Pull plunger out full length of stroke, allow it to return itself. Do this six times twice daily. Do not push plunger	
When level recedes to low limit on gage	8	Knee parts	Keep knee reservoir filled to line on gage. Keep column filled to bottom of threads of filler elbow. Drain and refill with clean oil after first month of operation. Thereafter drain and refill, while machine is stopped, about twice a year, depending on operating conditions. <i>Automatic Lubrication.</i> Quantities listed below	
Twice a Year	10	All parts in column (except motor), including gear shifter bracket and feed box	Replace pipe plug in vertical screw base nut with grease fitting. Fill oil well with grease gun. Once a day, run knee to bottom of stroke to assure coating of oil on vertical screw. (Oil pot is in base)	P-50 Heavy, non-corrosive, sulphur, extreme pressure base. Viscosity 190 to 100 seconds Saybolt, at 100° F. (Such as Shell Oil Co. E. P. Table May Lubricant S. A. E. 90.)
Twice a Year See Note *	9	Vertical screw	Front bearing is accessible when door on rear of column is opened. Rear bearing is accessible when toucer on right hand side of column is removed	Depends upon type of motor. Cup grease for anti-friction and oil for sleeve bearings
Depends on make of motor and type of bearing construction		Motor bearings		

*Note: If power vertical feed is used continuously, raise knee to top of stroke once a day and apply specified lubricant to vertical screw with brush.

Quantities required	Column	Knee
Nos. 1 and 2 Horizontal	3 1/2 gals	1 1/4 gals
Nos. 3 and 4 Horizontal	4 1/2 gals	2 1/2 gals
Nos. 1 and 2 Vertical	1 1/4 gals	1 1/4 gals
Nos. 3 and 4 Vertical	1 1/2 gals	1 1/2 gals

†Note: If the machine is operating continuously at the higher range of speeds, use a lighter oil (about 150 seconds vis.) in Station 10. If operated continuously at the lower range of speeds, use a heavier oil (about 275 seconds vis.)

CINCINNATI DIAL TYPE MILLING MACHINE

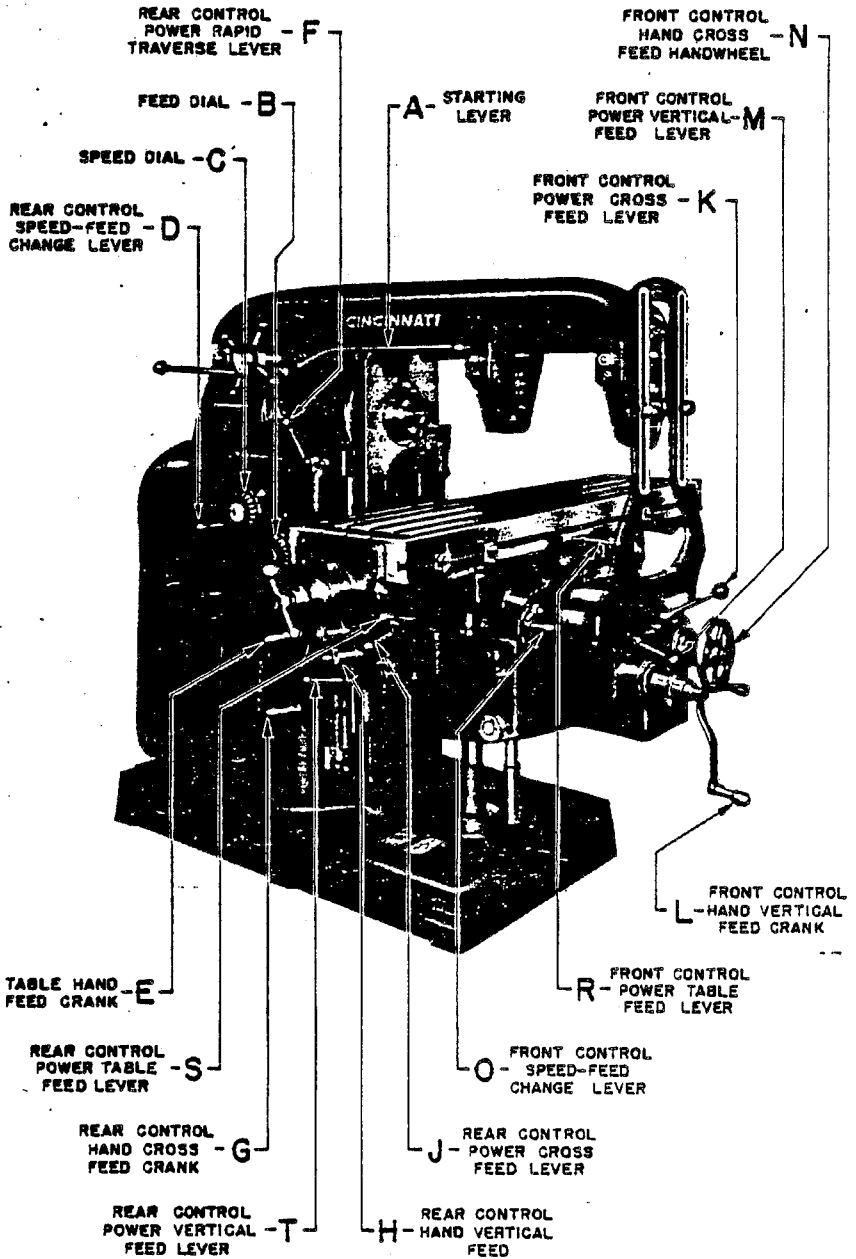

Figure 8
 Front View of Plain Dial Type Milling Machine
 Showing Operating Levers

OPERATING INSTRUCTIONS

(Refer to Figures 8, 9 and 10 for these Instructions)

Starting the Machine. Place the cross, vertical, and table feed levers ("K", "M" and "R", respectively) in their neutral or stop positions. (Fig. 10). Start the motor. *Note*—The hinged belt guard cover at the rear of the machine must be closed and latched before the push-button will start the motor. Push up starting lever "A" to start the rotation of the spindle. An automatic spindle brake is thrown into engagement when lever "A" is pulled down to stop the spindle.

Changing Spindle Speeds. Start the motor. With starting lever "A" in the stop position and the spindle stationary, move speed-feed control lever "O" to "SPEED". Note that dial "C" is now rotating. When the speed desired, shown on dial "C", registers with the arrow, release the control lever. Now pause a second or two and then push up starting lever "A". The spindle will rotate at the speed indicated by the dial and arrow. The short pause mentioned previously gives the gears time to fully engage, and thereby prevents clashing of the teeth

SPINDLE SPEEDS (r. p. m.)—HIGH SPEED MACHINES

Nos. 1&2	20	25	32	39	47	59	74	92	114	142	178	220	270	333	414	515	635	780	970	1200	1500
Nos. 3&4	18	22	27	34	41	51	63	78	97	122	152	188	230	286	357	445	550	675	840	1045	1300

SPINDLE SPEEDS (r. p. m.)—MEDIUM SPEED MACHINES

Nos. 1 and 2	20	26	32	40	47	60	74	92	116	141	179	222	262	331	414	500
Nos. 3 and 4	18	22	27	33	40	51	63	78	96	123	151	187	223	281	350	450

When working from the rear of the machine, the speed and feed index dials are controlled by lever "D". Note that control levers "D" and "O" are provided with safety pins to prevent them from being moved accidentally. On long run jobs, change speeds one full rotation of dial each day.

Hand Table Feed. Ball crank "E", Fig. 8, is for moving the table by hand when the power feed is disengaged. When the crank is rotated one turn in a clockwise direction the table moves to the right $\frac{1}{4}$ inch. The dial is graduated into 250 equal spaces, which is equivalent to .001" movement of the table for each space. All micrometer dials may be reset by merely pulling them out against a light spring pressure, and rotating them to the desired marking.

Hand Cross Feed. Hand wheel "N", Fig. 8, is for moving the saddle by hand across the top of the knee when working from the front of the machine, while crank "G" is for moving the saddle by hand when working from the rear. The crank is interchangeable from "G" to "H". One clockwise turn of the handwheel or crank moves the saddle $\frac{1}{4}$ inch towards the column. The dial is graduated into 250 spaces, which is equivalent to .001" movement of the saddle for each space.

Hand Vertical Feed. Crank "L", Figs. 8 and 9, is for moving the knee up or down when working from the front of the machine, while crank "H" is for moving the knee when working from the rear. One clockwise turn of either of these cranks moves the knee up $\frac{1}{10}$ inch. The dial is graduated into 100 equal spaces, which is equivalent to .001" movement of the knee for each space.

Power Table Feed Levers "R" and "S". Lever "R" is for engaging the power table feeds from the front of the machine, while lever "S" is for engaging the table feeds from the rear. They are both directional controls, that is, the table moves in the direction in which you move the lever.

Be certain to loosen the table clamping screws, Fig. 17, page 31, before engaging the power feed; and it is also advisable to tighten the saddle and knee clamping levers if using the table feed alone.

Power Cross Feed Levers "J" and "K". Lever "K" is for engaging the power cross feeds from the front of the machine, while lever "J" is for engaging the cross feed from the rear. They are both directional control levers; that is, the saddle moves in the direction in which you move the lever.

Loosen the saddle clamping lever, Fig. 16, page 30, before engaging the power cross feed; and it is also advisable to tighten the table clamping screws and knee clamping lever if using the cross feed alone.

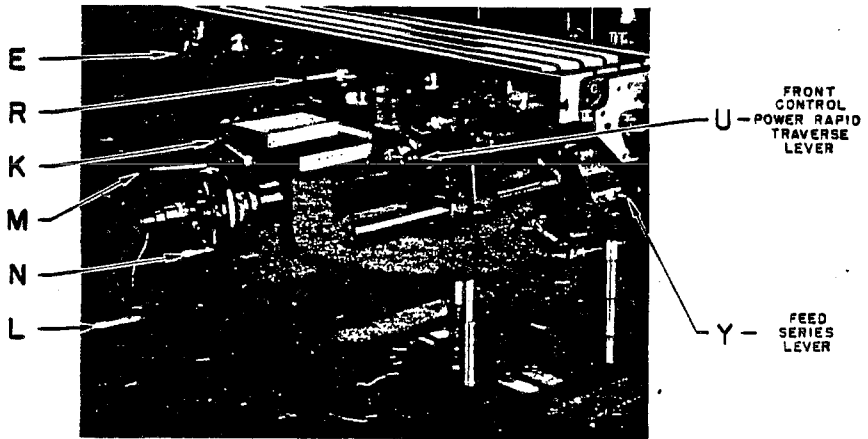

Figure 9
Right Hand View of Knee
Lever "Y" is on High Speed Machines Only

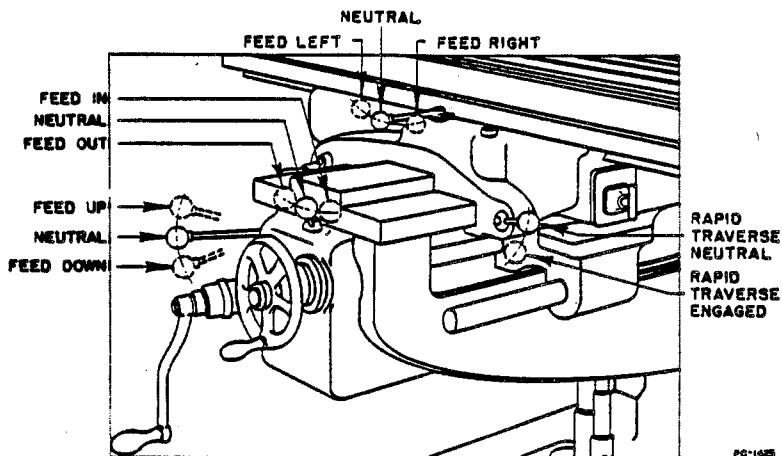

Figure 10

Engaged and Neutral Positions of Front Control Power Feed Levers

Power Vertical Feed Levers "M" and "T". Lever "M" is for engaging the power vertical feed from the front of the machine, while lever "T" is for engaging the vertical feed from the rear. They are both directional control levers; that is, if pulled up, the knee moves up; and if pushed down, the knee moves down.

Be certain to loosen the knee clamping lever, Fig. 16, before engaging the power vertical feed; and it is also advisable to tighten the table clamping screws, Fig. 17, and the saddle clamping lever, Fig. 16, if using this feed alone.

Feeds. The method of changing the feed rates, described below, is similar to the method of changing spindle speeds. If desired, any combination of feed motions, such as cross and table, may be engaged at the same time. The spindle must be running to obtain a feed movement. Reversing the direction of rotation of the spindle (explained on page 30) does not affect the direction of the feeds.

Changing Feeds. Start the motor. Starting lever "A" and the three feed engaging levers ("K", "M", and "R" Fig. 9) should be in their neutral or stop positions, and the feeds SHOULD NOT be changed while any of these levers are engaged. Move speed-feed control lever "O" to "FEED". Hold it in position until the feed desired, shown on dial "B", registers with the arrow, then release the lever. The proper feed gears are now in mesh to move the table at the feed rate indicated by the dial and arrow.

Notice that an auxiliary feed change lever is available for obtaining high feed rates on High Speed Machines. This lever, "Y" in Fig. 9, is located on the right hand side of the knee. When the lever is engaged in the stop at the left, the high series is engaged, and the feed rates are twice those shown on the feed dial. When engaged in the stop at the right, the low series is engaged, and the feed rates correspond to those shown on the dial.

STANDARD FEED RATES (Inches/Minute)
Medium Speed Machines (16 Feeds)

Dial "B" indicates the longitudinal and cross rates of travel. The vertical rate is .8 the indicated feed.

Table and Cross Feeds	1/2	5/8	3/4	1	1 1/8	1 1/4	2 1/8	2 1/4	3 5/8	4 5/8	5 3/4	7 5/8	9 7/8	12 3/8	15 3/8	20
-----------------------	-----	-----	-----	---	-------	-------	-------	-------	-------	-------	-------	-------	-------	--------	--------	----

STANDARD FEED RATES (Inches/Minute)*
High Speed Machines (32 Feeds)

Dial "B" indicates the low feed series for the table and cross traverse. The high feed series, which is twice the dial reading, is obtained by shifting lever "Y" (Fig. 9) to the left. The vertical rate of traverse is .8 the indicated feed with lever "Y" in the position shown, and 1.6 when it is shifted to the left.

Table and Cross Feeds, Low Series	1/2	5/8	3/4	1	1 1/8	1 1/4	2 1/8	2 1/4	3 5/8	4 5/8	5 3/4	7 5/8	9 7/8	12 3/8	15 3/8	20
Table and Cross Feeds, High Series	1	1 1/4	1 1/2	2	2 3/4	3 1/2	4 1/4	5 1/2	7 1/4	9 1/4	11 1/2	15 1/4	19 1/4	24 1/4	30 3/4	40

Power Rapid Traverse. The power rapid traverse, controlled from the front of the machine by the lever "U" (Fig. 9) and from the rear of the machine by lever "F" (Fig. 8), may be engaged at any time and for any direction of travel with the spindle either running or stationary. (Of course, the motor must be running.) The feed lever which will give the direction of travel desired must also be engaged at the same time that the rapid traverse lever is engaged.

For instance, suppose you want to use the *vertical* rapid traverse. Move the vertical feed lever up or down, according to the direction of travel desired, then hold the rapid traverse lever in its engaged position, (down). The sequence of engaging the levers is an important consideration in long life of the rapid traverse clutch—*always engage the feed lever first, especially when using the vertical rapid traverse.*

Releasing the rapid traverse lever instantly changes the rate of travel from rapid traverse to feed in the same direction.

When the machine is equipped with the standard feed series (listed on page 26) rapid traverse for the longitudinal and cross movements is at the rate of 100 inches a minute, and vertical at 80 inches a minute.

When the low feed series is engaged on High Speed machines (lever "Y", Fig. 9, to the right) the rapid traverse rates are 50 inches a minute longitudinal and cross, while the vertical rapid traverse is 40 inches a minute. When the machine is equipped with the special low feed series, i. e. $\frac{1}{2}$ of the standard rates tabulated herein, then all rapid traverse rates are divided by 2.

POWER FEED AND POWER RAPID TRAVERSE TO HEAD VERTICAL MACHINES

The power feed and rapid traverse attachment for the head of the vertical machines is a very handy device for tool room work. It is much more convenient than using the vertical travel of the knee for work requiring a short vertical feed, such as die making, end milling keyways, accurate boring, etc.

Refer to Fig. 13 for the operating instructions given on the following page.

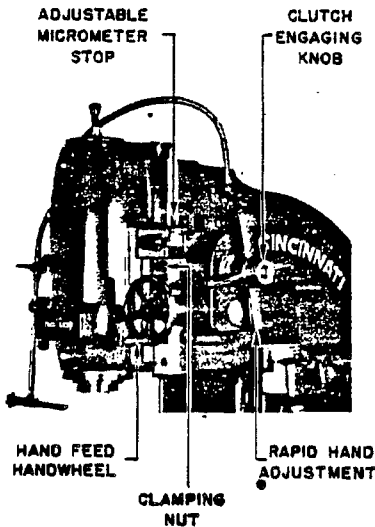

Figure 11
Standard Hand Feed to Vertical Head

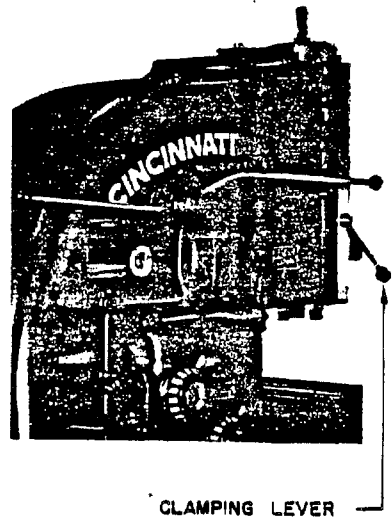

Figure 12
Left Hand Side of Vertical Head,
Showing Clamping Lever

Slow Hand Feed. Hand-wheel "Y" is for the slow hand feed of the head. With feed lever "X" in its neutral position (approximately horizontal) and lever "Q" at the high side of the eccentric, turn hand wheel "Y" in a clockwise direction to move the head down. One turn of the hand-wheel is equivalent to a head movement of .05". The dial is graduated into 50 equal spaces, which is equivalent to .001" for each space.

Rapid Hand Feed. Hand-wheel "W" is for the rapid movement of the head by hand. With levers "X" and "Q" in the positions noted above, turn hand-wheel "W" in a clockwise direction to move the head up. One turn of the hand-wheel moves the head 6".

Power Feed. The feed is taken directly from the feed box on the side of the machine, through a spur and bevel gear drive and then through a worm and worm wheel to the rack on the head. **Loosen nut "Z"** (Fig. 13) and the clamping lever on the left hand side of the head before engaging the power feed or before moving the head by hand. The head of the *high speed* verticals moves at a rate of approximately .6 *the dial reading*, and the head of the *medium speed* verticals moves at a rate of .5 *the dial reading*.

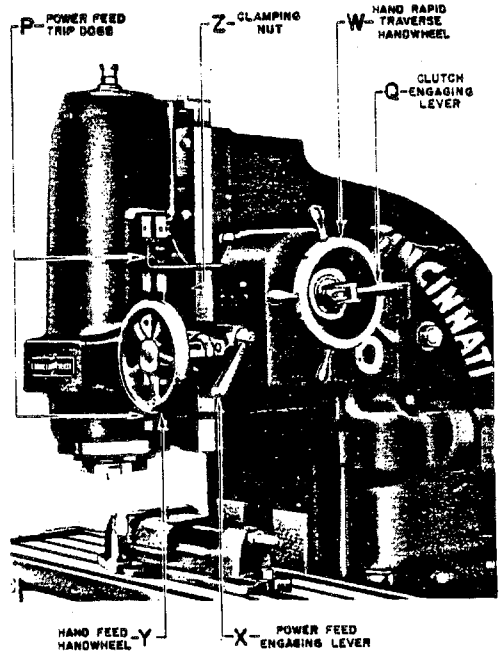

Figure 13
Vertical Head Arranged with Power Feed

POWER FEEDS TO SLIDING VERTICAL HEADS

*Feed Indicated by Feed Dial	1/2	5/8	3/4	1	1 1/8	1 1/4	1 1/2	1 3/4	2	2 1/4	2 1/2	2 3/4	3	3 1/4	3 1/2	3 3/4	4	4 1/4	4 1/2	4 3/4	5	5 1/4	5 1/2	5 3/4	6	6 1/4	6 1/2	6 3/4	7	7 1/4	7 1/2	7 3/4	8	8 1/4	8 1/2	8 3/4	9	9 1/4	9 1/2	9 3/4	10		
Actual Feeds to Head High Speed Machines	.3	.375	.45	.6	.825	1.05	1.28	1.65	2.18	2.78	3.45	4.58	5.93	7.43	9.23	12																											
Actual Feeds to Head Medium Speed Machines	1/4	3/8	1/2	5/8	3/4	7/8	1 1/8	1 1/4	1 1/2	1 3/4	2	2 1/4	2 1/2	2 3/4	3	3 1/4	3 1/2	3 3/4	4	4 1/4	4 1/2	4 3/4	5	5 1/4	5 1/2	5 3/4	6	6 1/4	6 1/2	6 3/4	7	7 1/4	7 1/2	7 3/4	8	8 1/4	8 1/2	8 3/4	9	9 1/4	9 1/2	9 3/4	10

*Note—If the machine has a special feed series of 1/4" to 10", feeds to head on medium speed machines are same as indicated on dial.

Lever "X" is a directional control lever for engaging the power feed to the head. To engage the feed, start the machine, move lever "Q" to the high side of the eccentric, and then move lever "X" in the direction you want the head to travel.

Power Rapid Traverse. The power rapid traverse is controlled by feed lever "X" and the regular rapid traverse lever (Fig. 9) in front of the saddle. Move the feed lever in the direction you want the head to move and then hold the quick traverse lever in its engaged position. The rapid movement of the head is at the rate of 44" a minute for the medium speed machine and 31" a minute for the high speed machine. See paragraph entitled "Four Position Turret Stop and Dial Indicator."

Clamping the Head in Position. Nut "Z" is for clamping the head in position. The lever on the left hand side of the head casting (Fig. 12) is a quick acting clamp which is convenient when using the feed to the head.

Trip Dogs. Dogs "P" disengage the power feed by striking a small plunger which is connected to lever "X". Do not remove the stop screws which limit the position for setting these dogs in an effort to obtain greater travel to the head.

Lever "Q" is for disengaging the worm drive when it is necessary to move the head with hand-wheel "W"

Four-Position Turret Stop and Dial Indicator. The downward power rapid traverse movement of the head should be disengaged before the turret stop screw contacts the plunger at the top of the indicator bracket. Failure to do so may result in a wreck, as the head may "coast" after tripping the feed plunger. The turret stop should be used as a feed trip only. After tripping, the head should be adjusted to final position by hand while noting the indicator reading.

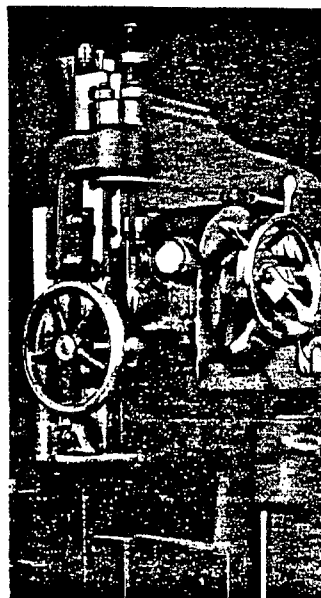

Figure 14
Four-position Turret Stop
and Dial Indicator

SETTING UP THE MACHINE

(Refer to Figs. 15, 16, 17 and 18)

Overarm, Supports and Braces. Loosen nuts "B-B" and move the overarm to the desired position by turning pilot wheel "A". If the cutter chatters an excessive amount during the cut, it is advisable to use the overarm braces to correct this fault.

Clamping Devices for Sliding Units. Screws "H", through intermediate shoes, clamp the table in position when tightened. Tighten these screws only when using the cross or vertical feed alone. Do not tighten them when using the table feed, or the table gib will wear in the spots at which the pressure from the screws is applied, and there is also much more liability of the bearings "scoring" due to the bearing pressures being concentrated.

Lever "L" is for clamping the saddle in position when using the table or vertical feed. Do not tighten this lever when using the cross feed, as there is danger of scoring the bearings in the same manner as described in the preceding paragraph.

Clamp the knee in position when using the table or cross feed by tightening lever "F". Do not tighten this lever when using the vertical feed, as there is danger of scoring the column bearings.

Reversing the Direction of Rotation of the Spindle. The direction of rotation of the spindle must be the same as the "hand" of the cutter; that is, the rotation must be clockwise for a "right hand" cutter, and counter-clockwise for a "left hand" cutter. The direction of rotation is controlled by lever "C", as shown by the spindle reverse plate near it. Do not try to move the reverse lever while the spindle is in motion.

Note that "RIGHT" and "LEFT" on the spindle reverse plate indicates the direction of rotation of the spindle when viewed from the rear of the machine.

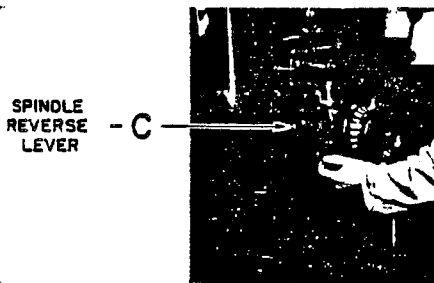

Figure 15

View showing Spindle Reverse Lever on Gear Shifter Bracket. Lever "C" is Locked in Neutral Position When Machine is Shipped

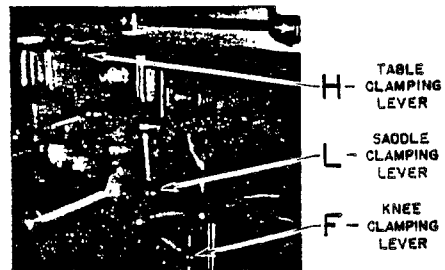

Figure 16

Right Hand View of Knee of Medium Speed Machine

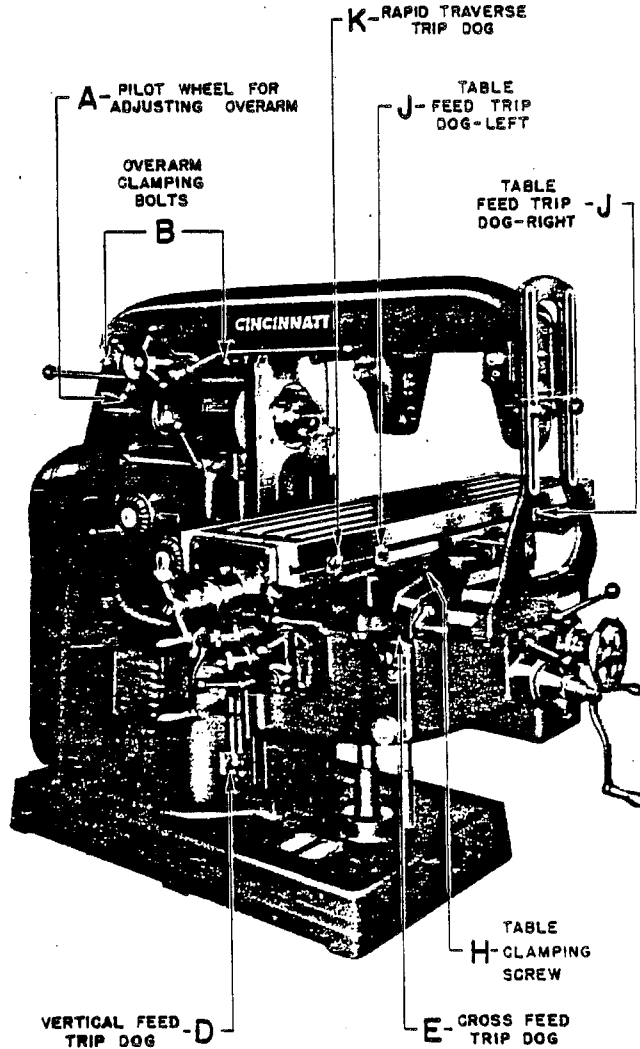

Figure 17
Front View of No. 2 Dial Type Horizontal Miller

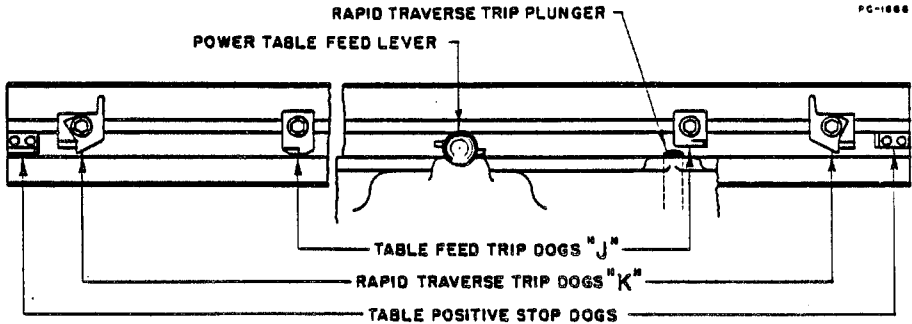

Figure 18
Table Dogs, Plain and Vertical Machines.
Long Dog must be to the Left of the Table
Feed Lever, Short Dog to the Right

Trip Dogs. Dogs "J" are for automatically stopping the table feed at the end of the cut or at any desired point in the table travel, while dogs "K" (plain and vertical machines only) automatically trip the table rapid traverse. Do not remove the stop dogs which limit the position for setting the trip dogs. These stop dogs are used as a safety measure to prevent the trip dog being set beyond the actual range of the table. If the job requires a greater travel than the machine allows, it must be milled on a larger machine with greater range.

Dogs "E" are for automatically stopping the cross feed at any desired point in the cross travel. Safety dogs prevent them from being set beyond the actual cross range of the machine.

Dogs "D" are for automatically stopping the vertical feed at any desired point in the vertical travel. Do not remove the stop screws which limit the position for setting these dogs.

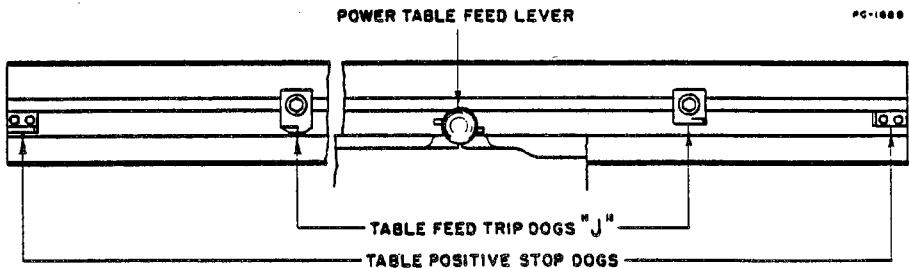

Figure 19
Table Dogs—Universal Machines

Setting Up the Fixture and Cutters. Clamp the fixture in the center of the table, or as near the center as operating conditions will permit, to avoid as much as possible the excessive overhang of the table which causes wear on the ends of the table gib and saddle bearings. If you are using a lathe dog for holding the work, do not under any conditions use the T-slots of the table for tightening the dog screw. When these T-slots become marred, the work or fixture which is located from them will not line up properly, with the result that a new table must be purchased or the old one re-planed to obtain accurate work.

When using a cutter on an arbor, the cutter must fit accurately and the arbor must run true between dead centers to obtain the best finish on the work and freedom from chatter. The cutter must be a snug fit on the arbor for the same reason. The ends of the spacing collar and arbor nut must be perfectly clean before assembling, because dirt particles between the collars will spring the arbor when the nut is tightened. Always use as short an arbor as possible, and space the cutter as near to the spindle as operating conditions will permit.

When placing a face mill on the spindle, the best method is to place the mill on a block of wood resting on the table, and then raise the table until the face mill will slip over the spindle nose without undue exertion. Tighten each face mill screw a fraction of a turn until they are all tight.

Cast Iron and Steel Set-Ups. When milling a material which does not require coolant, all strainers should be protected with the covers provided for them to keep fine chips and particles of metal out of the coolant system. If the machine is to be run with such a set-up for a long period of time, it is advisable to pump the coolant out of the reservoir. However, *do not run the standard gear pump without coolant* in the base, as the gears depend upon the coolant for lubrication. The pump driving gear, visible when the door on the rear of the column is opened, may be slid out of engagement with the pump. (Fig. 32, page 45).



Figure 20
Setting the Spindle
Speed Calculator

Speed Calculator. The size and kind of cutter, work material, cutting speed, and cutter R.P.M. are all calibrated on the calculator. By properly setting two discs, you can quickly determine the correct cutter speed. Three factors must be known:

1. Cutter diameter; for example, assume 3".
2. Cutter material; assume High Speed Steel.
3. Work material; assume SAE-1045 steel.

To set the calculator, proceed in the following manner:

1. Rotate the red disc until the cutter diameter (3") registers with the small arrow above the upper window.
2. Rotate the black disc to bring the cutter material (High Speed Steel) in the lower window.
3. Now follow left and downward from the work material (SAE-1045 steel) shown on the black disc, to read on the red scale the recommended cutter R.P.M., which is about 80 to 97 R.P.M.

Choose the spindle speed available on the machine nearest to—or within—this range, taking into consideration, of course, the hardness of the work piece and the general conditions of the cut. In the case of the CINCINNATI No. 2 High Speed Dial Type Milling Machine, for example, the spindle speeds available in this neighborhood are 74 and 92 R.P.M., thus where the cutting conditions are normal (as we may assume in the present case), the 92 R.P.M. speed should be selected, while if the work piece has been given a hardening or toughening heat treatment, or conditions are otherwise unfavorable, the next lower speed (74 R. P. M.) should be chosen.

The cutting speed or peripheral speed of the cutter for the recommended R.P.M. may be found if desired by reading directly from the red scale to the black scale. Thus, for the above example, with the same setting as in Fig. 20, opposite 92 R.P.M. will be found 72 feet per minute, while opposite 74 R.P.M. will be found 58 feet per minute.

CUTTING FLUIDS

Several types of cutting fluids are available for milling operations, but only two are considered here; (1) Cimcool, a product of The Cincinnati Milling Machine Co. and (2) soluble oil, sold by most oil companies. Cimcool is recommended because of certain outstanding advantages, particularly in cleanliness and sterility, and absence of vapors, hot chips and slippery film.

Good results will be obtained by following the suggestions outlined in the next three paragraphs.

Cast iron. Ordinarily, cast iron may be milled dry. If the cutter is small and the cut is relatively deep, as when T-slotting or rounding out keyways, an air blast from the compressed air line will keep the cutter sufficiently cool and will also clear out chips.

Brass, soft bronze, and aluminum—milled dry. If the part deforms from the heat of machining, or is too hot to handle, cutting fluids may be used. Use one part of Cimcool or soluble oil to forty parts of water.

Steel, malleable iron, wrought iron, and hard bronze—A mixture of one part of Cimcool in forty parts of water is suitable for most milling operations, although a richer mix up to one part of Cimcool in twenty parts of water may be used for hard steel. Soluble oil may be used in richness varying from one part in ten parts of water for hard steel to one part in forty parts of water for malleable iron.

CLEANING THE COOLANT RESERVOIR AND COOLANT STRAINER

The coolant reservoir in the base of the machine should be cleaned out occasionally to maintain the full capacity for coolant; and to prevent grit from circulating with the coolant and thereby wearing out the pump gears too rapidly. Remove the cover over the cleanout opening at the side of the base, Fig. 21. With the aid of a small scraper, similar to the soot scraper for the old-fashioned coal range, scrape out the sludge.

The coolant strainer should be cleaned about once a week to assure a free flow of coolant. Loosen the coupling next to the pump and lift out the suction line and strainer. Wash the strainer in kerosene or naphtha, and blow it out with an air hose.

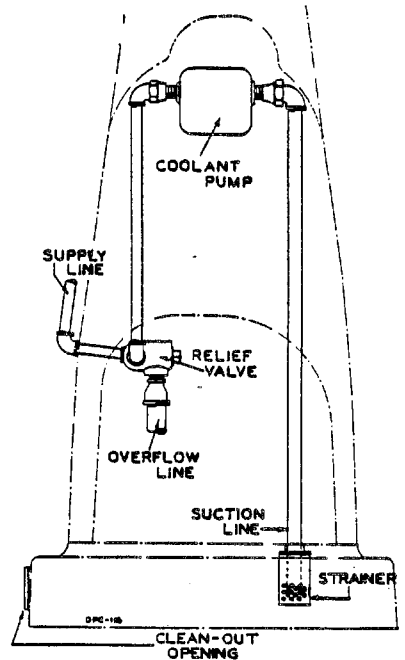

Figure 21
Coolant Pump, Relief Valve,
and Strainer

ADJUSTMENTS

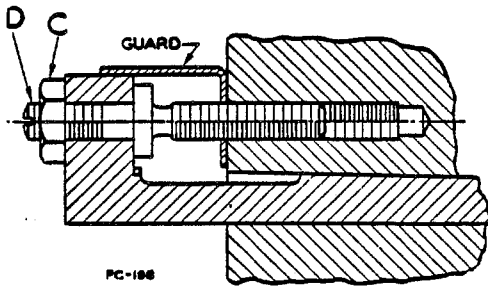

Figure 22
Section Through Head Type Gib
with Guard

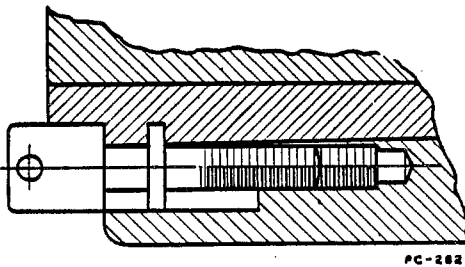

Figure 23
Section Through Headless
Type Gib

Adjusting the Gibs. Two types of gibs, shown in Figs. 22 and 23, are used to take up the wear between the sliding units. The amount and method of adjustment, however, are about the same for each type. Adjust the gib inward (the screws have right hand threads) and try the movement of the unit with the hand crank.

When adjustment of the gibs is necessary, they should never be drawn up so tightly as to prohibit free movement of the particular unit by means of the hand crank. Tight adjustment squeezes out the oil film and causes scoring and untimely wear. Clean the bearings of the sliding units occasionally to avoid undue wear on the ends of the gibs.

Be sure to retighten nut "C" when adjusting head type gibs.

Adjusting the Tension in the V-Belts

1. Open the hinged cover on the rear of the machine. (Fig. 32, page 45)
2. Adjust the hinged motor base downward by loosening the lower nut and tightening the top nut on the adjusting screw at the right. A good general rule for proper tension: when struck with the hand, belts are tight but springy.
3. Tighten the adjusting nuts securely.
4. A few words on the care of V-belts: Keep oil and grease away from them. Never apply belt dressing. Be sure pulleys are in line; adjustable motor rails are provided for this purpose.

Adjusting the Driving Clutch. The clutch for these machines is self-compensating within certain limits, thereby eliminating the necessity for adjustment until the wear exceeds these limits. Nut "B", (Fig. 24), regulates the allowance for the self-compensating effect, or wear; which is about .020" when the clutch is new or after it is adjusted.

The position of nut "A" determines the force transmitted by the spring to the clutch plates, and therefore determines the load which the clutch will carry. Nut "A" is set by our assemblers to obtain the full capacity of the spring; therefore it should not be moved within the life of the clutch.

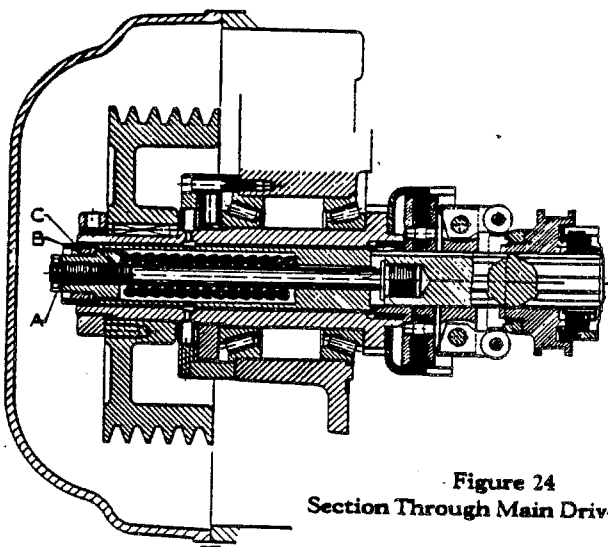

Figure 24
Section Through Main Drive Clutch

To make the adjustment to insure proper clutch engagement, proceed as follows:

1. Start the motor, fully engage the starting lever, stop the motor.
2. Open the door over the pulley bracket unit.
3. Remove the cotter pin through nut "B".
4. Turn nut "B" in a clockwise direction as far as it will go (touches nut "A"), then back it away about two notches.
5. Replace the cotter pin.

The clutch may be worn to such an extent that nut "B" can not be turned in a clockwise direction, as stated in step No. 4. If this condition exists, do not try to force it; just back it away the required amount. If, after making the adjustment, the spindle rotates slowly with the starting lever in the stop position, nut "B" has been backed away too far, allowing the

clutch plates to contact with the clutch finger holder in the stop position. When the clutch is properly adjusted, spring sleeve "C" will move out about .020" when the starting lever is pushed up.

Because of the hydraulic clutch engaging device, there is no longer the "feel" of correct adjustment as present in a mechanical design. Therefore, be sure the adjustment is made carefully and accurately. Any other procedure may ruin the clutch.

Adjusting the Rapid Traverse Clutch. If the rapid traverse clutch is slipping, it must be adjusted before undue wear takes place. Proceed in the following manner:

1. Remove the small brass cover "D" which is held to the feed box by four $\frac{1}{4}$ " hex head cap screws, Fig. 25. (These instructions are also engraved on this cover).
2. Loosen screw "A".
3. Pull out lock pin "B" and turn adjusting yoke "C" towards the plates. (The threads are right hand).
4. See that lock pin "B" is engaged in one of the holes. Tighten screw "A". Try pin "B" to be sure that it moves freely in and out of the locating hole.
5. Replace cover "D".

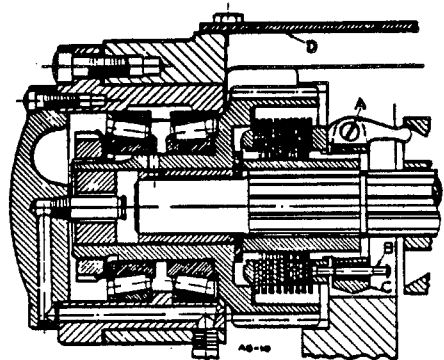

Figure 25
Section Through Rapid Traverse
Clutch

Rapid Traverse Plunger Too High. Evidence of extreme wear of the rapid traverse clutch may be evident in the amount the plunger extends out of the saddle. (It moves in conjunction with the movement of the rapid traverse lever). If this plunger is so high that the rapid traverse dog will not clear, the clutch should be adjusted as explained in the preceding paragraph.

Adjusting the Table Feed Screw Bearings. The table feed screws of these millers are provided with adjustable tapered roller bearings at each end. When adjustment is necessary, adjust the right hand bearing only.

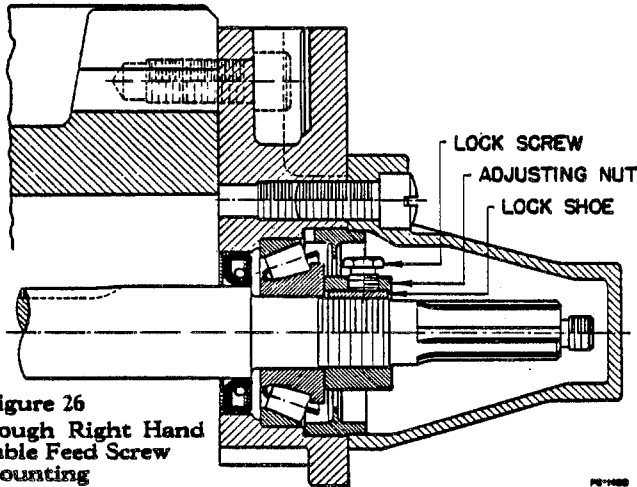

Figure 26
Section Through Right Hand
End of Table Feed Screw
Mounting

1. Remove the cone shaped cover over the end of the table feed screw at the right hand end of the table.
2. Loosen the hex head screw through the adjusting nut, and tap the screw and nut to loosen the lock shoe.
3. Tighten the adjusting nut with a face spanner wrench, and then back away about 1/16 turn or less.
4. Re-tighten the hex head screw and replace the cover.

Turn the table feed ball-crank with the power feed disengaged and try to determine by the "feel" whether the bearings have been adjusted correctly. They should not be adjusted so tightly as to make it difficult to move the table, but on the other hand, there should not be a noticeable amount of "play" in the bearings. It is important, of course, to see that the table gib is loose enough so that the table can be easily moved in order to differentiate between a tight lead screw bearing and a tight gib bearing.

When the "play" is caused by a worn lead screw and nut, it is necessary to replace these parts in order to obtain accurate work.

Adjusting the Cross Feed Screw Bearings.

1. Remove the screw at the end of the cross feed screw, and remove the cross feed hand wheel (Fig. 27).
2. Remove the screw plug through the diameter of the cross feed dial.

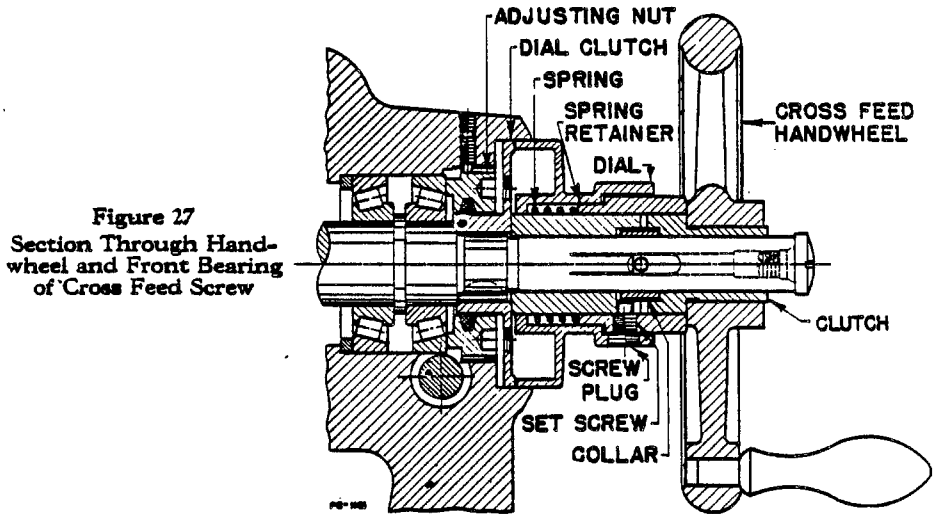

Figure 27
Section Through Hand-wheel and Front Bearing of Cross Feed Screw

3. Turn the dial until a set screw is visible through the pipe plug hole. Remove this screw.
4. Slip the dial, spring retainer and spring off the clutch.
5. Knock out the taper pin through the clutch, remove the collar screw from the oblong slot, and remove the clutch and collar.
6. Insert eye bolts into the two threaded holes in the dial clutch, and remove it by pulling straight out.
7. The adjusting nut is now visible. However, before it can be adjusted, two dog point locking screws must be removed. These screws, one on top of the other, will be found in the knee casting near the dial.
8. With a face spanner wrench, adjust the bearing nut until tight, and then back away one slot.
9. Replace the parts in the reverse order in which they were removed.

Turn the cross feed hand wheel with the power feed disengaged and try to determine by the "feel" whether the bearings have been adjusted correctly, as explained under "Adjusting the Lead Screw Bearings."

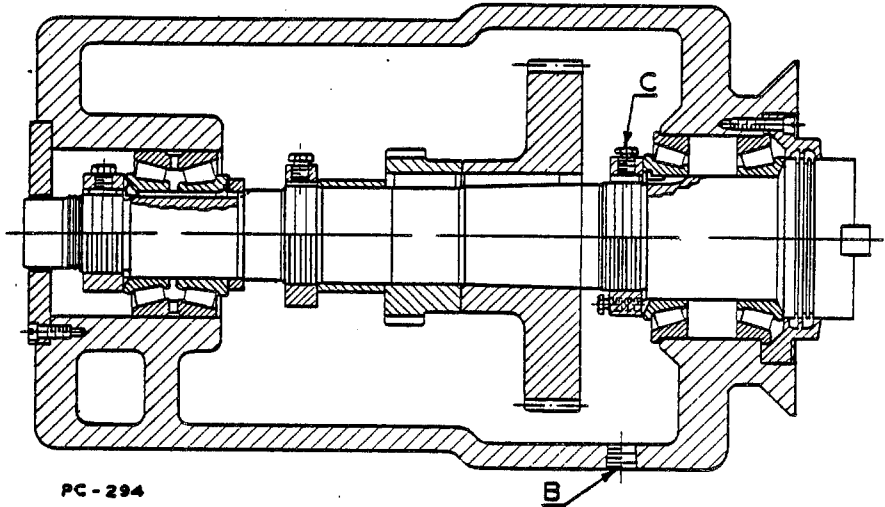

Figure 28
Section Through Spindle of Horizontal Machine

Adjusting the Spindle Bearings

1. Shift the spindle reverse lever to its middle position.
2. Remove two keys in face of spindle. Clamp a rectangular rod, about 10 or 12 inches long, in the key slots.
3. Horizontal Machines—remove pipe plug "B" at the side of the column (Fig. 28).
Vertical machines—remove the small rectangular plate in front of the vertical head.
4. Loosen hex head screw "C" and tap the socket wrench to loosen the shoe in the locknut.
5. With the socket wrench in position, turn the spindle counter-clockwise about a revolution and then clockwise until the bearings are drawn up snug. (Important—see last paragraph on end play).
6. Re-tighten hex head screw "C" and remove the wrench.
7. Now rotate the spindle several times by hand to properly seat the bearings.
8. Replace the pipe plug and remove the rod from the face of the spindle.

Adjustment of the front bearings only is sufficient in all cases and the rear bearings should not require attention.

Machines which are used for general purpose work should have about .001" end play in the spindle bearings. Machines for high speed work exclusively,

such as those for high speed carbide milling, should have about .002" end play in the spindle bearings. These readings are taken with the bearings cold.

This "end play" can be measured by indicating the end of the spindle nose with a $\frac{1}{10000}$ indicator and lightly tapping the spindle from the front to the rear and reading the indicator dial. The temperature of the spindle when run continuously at its highest speed for four hours, should not exceed 145° F. when properly adjusted. Test the temperature with a thermometer inserted into one of the screw holes in the spindle cap.

Speed Gears Fail to Shift. If the speed gears do not shift, the difficulty may usually be traced to dirt in the oil or a poor grade of oil, causing the relief valve plunger to stick and hold the ball off its seat.

CLEAN-OUT
FOR RELIEF - A
VALVE

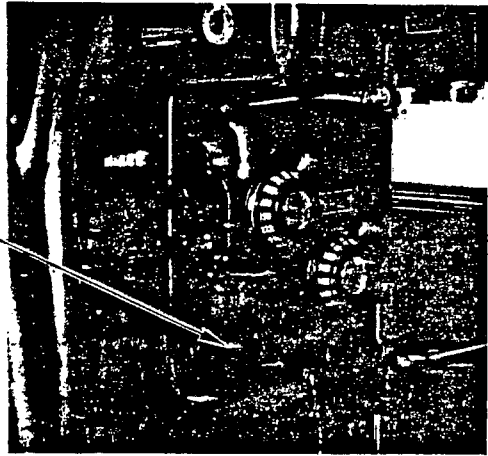

Figure 29
Gear Shifter Bracket

Ordinarily, this condition can be easily corrected by removing screw "A", Fig. 29, while the motor is stopped, and blowing a strong blast of air in the hole. If this does not help, it may be necessary to adjust the pressure of the oil pump in the column (see next page) or to remove the gear shifter bracket. Instructions for removing this unit are given in "Service Manual and Repair Parts Catalog for CINCINNATI Dial Type Milling Machines", a copy of which was sent with the machine. Only experienced maintenance men should do this job.

Setting the Oil Pressure of Pump in Column. This adjustment should not be required at any time, except perhaps to correct a previous mis-adjustment.

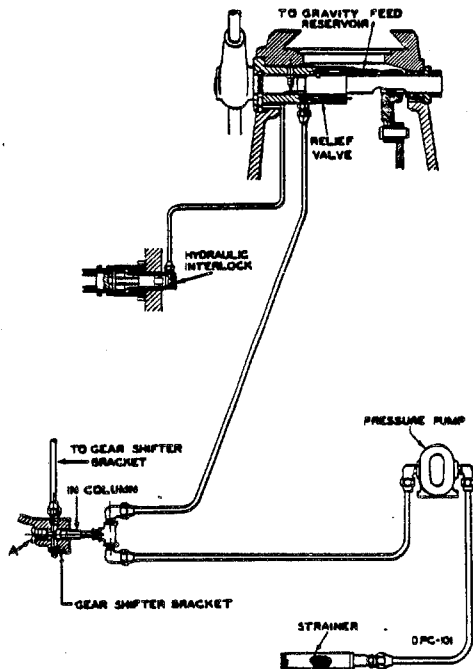

Figure 30
Oil Pump and Piping in Column

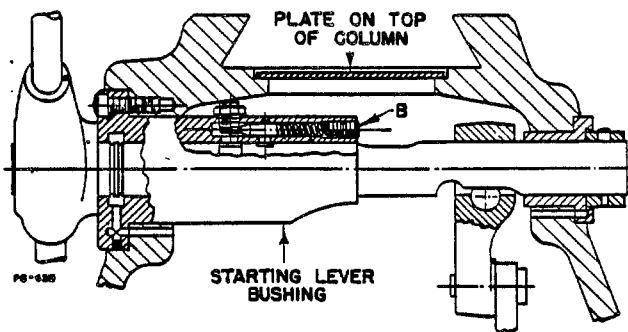

Figure 31
Section Through Relief Valve and
Starting Lever Bushing

1. Remove screw plug "A", Fig. 30, at bottom of gear shifter bracket. Screw at least a 500 lb. hydraulic gage in this connection. This is a $\frac{3}{4}$ -16 R. H. tapped hole and requires a special fitting, or drill and tap $\frac{1}{4}$ " pipe thread through plug "A" for gage.
2. Pull overarm forward to uncover plate on top of column, Fig. 31. Remove this plate.
3. Remove first of two $\frac{3}{8}$ " hollow headless set screws in the end of starting lever bushing at "B", Fig. 31.
4. Turn second screw at "B" in to increase gage pressure. It should be 290 lbs. to 310 lbs. Replace locking screw.

SAFETY PRECAUTIONS

The table and vertical traverse dog slots are provided with stop dogs and screws, respectively, which limit the position for setting the trip dogs. Do not remove these stops or the trip dogs in an effort to obtain more travel, as serious damage to the machine may result. If the job requires a greater range than the safety stops and dogs allow, it must be milled on a machine with greater table travel.

Safety dogs for the cross traverse are pinned in place, making it impossible to exceed the cross traverse.

If the spindle speed decreases when the table starts to feed the work into the cutter, the motor or clutch is at fault. Have the motor inspected and repaired, if necessary, by an experienced repair man. Then again note the action of the spindle when cutting. If it still slows down a noticeable amount, adjust the driving clutch as described on page 38. To avoid possible damage to the clutch or motor, make these corrections as soon as you notice the spindle speed decreasing under load.

The clutches on all hand cranks are provided with releasing devices to keep them out of engagement while they are not in use. Do not remove the device for the sake of keeping the crank in engagement, as it may result in serious injury to yourself or some other operator.

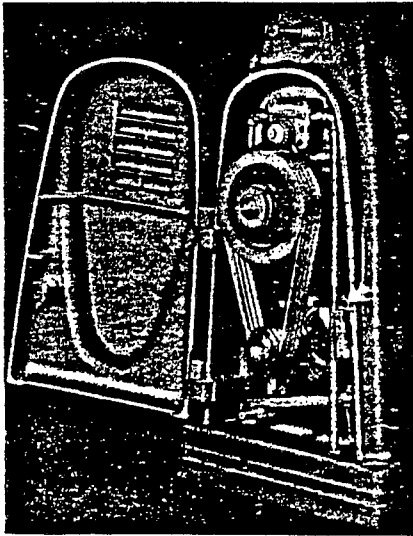

Figure 32

Hinged Cover Open to Show Belt Tension Adjustment, Safety Switch and Gear Driven Coolant Pump.

Do not try to reverse the direction of rotation of the spindle while it is in motion.

If you should decide to inspect the V-belts or the motor, and forget to shut off the electric current at the push-button station, the motor will stop as soon as the hinged cover at the rear of the machine is opened. The contact switch just above the latch bracket on the column, (indicated by arrow, Fig. 32) compensates for such an oversight by automatically breaking the circuit. When again starting the machine, it will be necessary, of course, to latch the cover and push the starting button.

DIVIDING HEAD

Cincinnati Dividing and Spiral Milling Heads are used extensively in milling spiral and helical gears, constant velocity drum cams, etc. The manner of transmitting motion to the spindle in the head is the same for both types, but the construction of the main castings are entirely different. The Dividing Head is designed so that its spindle can be swiveled vertically, while the spindle of the Spiral Milling Head is rigidly fixed in a one-piece housing to provide an attachment suitable for heavy and continuous helical milling. Change gears are the same for both types of heads and therefore the tables and instructions in this booklet apply to both types, *but the driving mechanism units (Figure 37) are not interchangeable from one to the other.*

The spindle of the Dividing Head is housed in a swivel block, allowing it to be swiveled to any angle from 5° below the horizontal to 50° beyond the vertical. This arrangement permits bevel gears of any pitch angle to be milled, and many other types of work requiring concentrically spaced slots or holes at an angle to the center line of the work piece.

The tailstock centers may be swiveled, and also raised or lowered, for taper work. The center-bar is reversible, to bring either the large or the small center point into working position.

There are a few oil cups in the Dividing Head. Be sure to apply oil periodically.

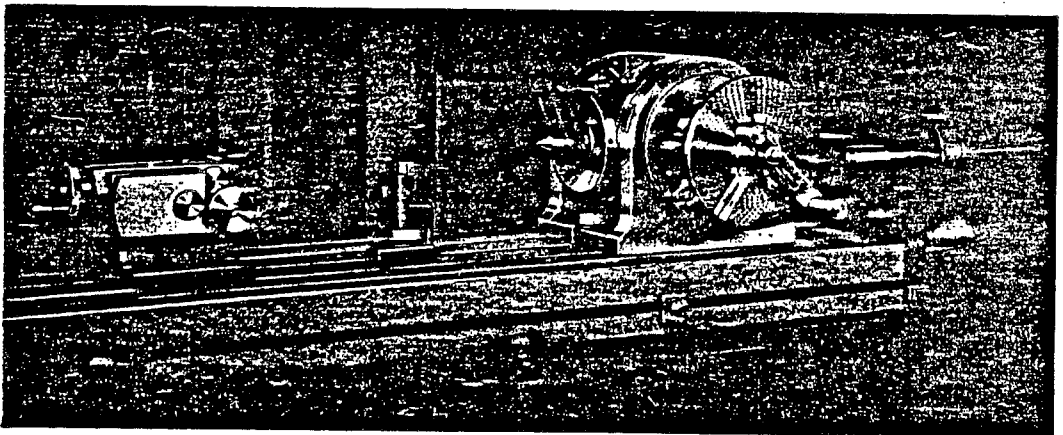

Figure 33
12" Dividing Head, Tailstock, Steadyrest and Driving Mechanism

DIVIDING HEAD

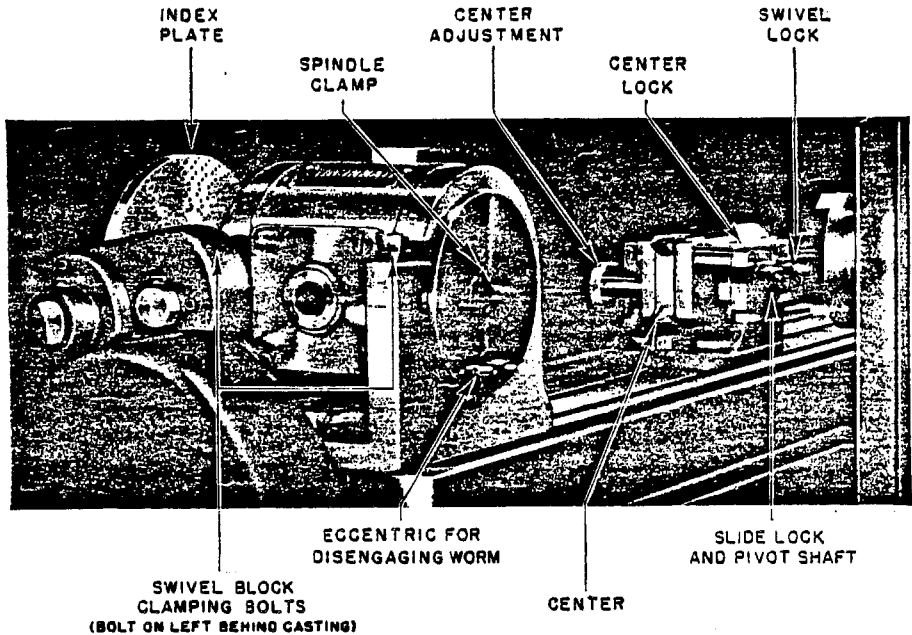

Figure 34
Rear View of the 10" Dividing Head and Tailstock

Because of the splined shaft drive, the Dividing Head headstock need not be placed flush with the end of the table when set up with the driving mechanism on the Nos. 3 and 4 machines. (See Fig. 33 for example). The 12" and 14" heads, on the No. 3 machines, may be connected to the driving mechanism a maximum of 10 $\frac{1}{4}$ " from the end of the table. On the No. 4 machines, the 12" and 14" heads may be power driven while clamped as much as 14 $\frac{1}{4}$ " from the end of the table.

SPECIFICATIONS FOR DIVIDING HEADS

	Size	Actual Swing	Taper Hole in Spindle	Overall Length of Tailstock	Overall Length of Head	Distance from End of Spindle to Table when Spindle is Vertical	Approx. Weight	
							Dividing Head	Tailstock
Dividing Heads.	10"	10 $\frac{3}{8}$ "	10 B&S	6 $\frac{4}{8}$ "	13 $\frac{1}{8}$ "	10 $\frac{7}{8}$ "	140 lbs.	39 lbs.
	12"	12 $\frac{1}{2}$ "	11 B&S	7 $\frac{1}{8}$ "	15 $\frac{1}{8}$ "	12 $\frac{1}{4}$ "	225 lbs.	52 lbs.
	14"	14 $\frac{1}{2}$ "	11 B&S	7 $\frac{1}{8}$ "	15 $\frac{1}{8}$ "	13 $\frac{1}{4}$ "	233 lbs.	55 lbs.
Ratio	40 to 1							
Holes Drilled in Index Plate . . .	One side— 24, 25, 28, 30, 34, 37, 38, 39, 41, 42, 43 Other side— 46, 47, 49, 51, 53, 54, 57, 58, 59, 62, 66							

The Sector. Index plates on all CINCINNATI Dividing Heads, Spiral Milling Heads and similar equipment have a sector for convenience in indexing. Fig. 35 shows the sector set for 220 divisions, which requires that, for each division, the index pin move over a series of twelve holes (spaces) in the 66-hole circle. The hole in which the index pointer rests, should not be counted when setting the sector. This factor is sometimes the source of a mistake in setting up dividing head work, and must not be overlooked.

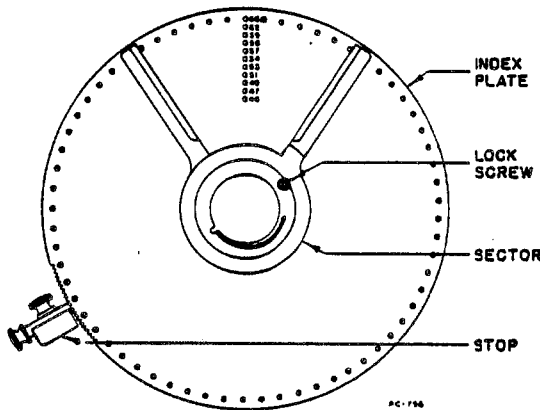

Figure 35
Dividing Head Sector Set for 220 Divisions

After the sector is spaced for the desired number of holes and tightened with the lock screw, no further counting of holes is necessary. Merely withdraw the index pin from the hole next to the left hand arm of the sector, relocate it in the hole next to the right hand arm, and then swivel the sector to again bring the left hand arm against the pin. The Dividing Head spindle and work will then have rotated $1/220$ revolution (for the set-up illustrated).

Example: Suppose you want the proper setting for a 21-tooth gear. Consulting the "Index Tables" you will find that for 21 divisions you must use the 42 hole circle. Set the index plate so that the side which has the 42 hole circle faces the index pin. Set the pin in any hole in that circle and space the sector for 38 spaces. Then for each of the 21 divisions, rotate the index pin through one revolution of the crank, plus the spacing of the sector, or 38 spaces.

Index Plate Stop. The index plate stop, Fig. 35, engages notches in the index plate, preventing it from rotating. If the Head is connected to the driving mechanism for a spiral or helical milling job, the index plate, sector, and crank rotate as a unit. For such a set-up, *the stop must be disengaged from the plate.* In other words, the stop should be engaged only when the Dividing Head is not connected to the power drive, as when milling spur

gears, bolt heads, etc. The stop serves as a safety precaution in preventing mistakes which would occur if the index plate itself were moved slightly while indexing.

The index plate stop may also be used as a guide to accurately reset work which has been removed from the Dividing Head for purposes of inspection. First reset the work in approximate relation with the cutter. Then withdraw the index plate stop, and with the index pin engaged, rotate the crank a sufficient amount to accurately position the work. Re-engage the stop in the notches on the rim of the plate. Two inches of the circumference of the plate is notched, and the notches have a pitch of .060". Therefore, a movement of one notch on the index plate is equivalent to $\frac{1}{18460}$ of a revolution of the work.

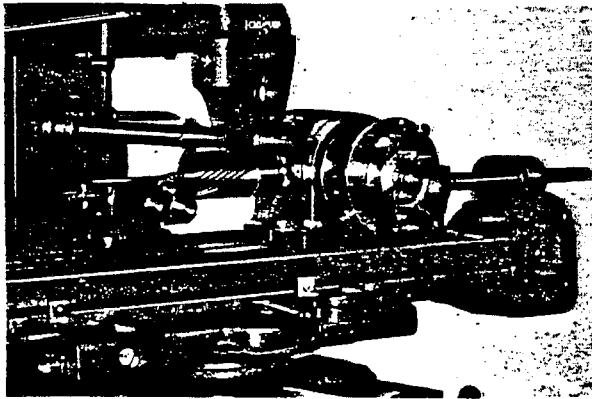

Figure 36
Dividing Head Set-Up for Milling Helical Gears

Setting Up the Dividing Head and Driving Mechanism. The instructions outlined for this set-up should be followed in the order in which they are listed.

1. Clean the table of the milling machine and the bottom of the dividing head and tailstock.
2. Clamp the dividing head headstock in the center slot of the table, in a suitable position for the length of the work. (On No. 2 Machines only, the rear of the headstock must be approximately flush with the right hand end of the table).

3. Test the dividing head spindle with a test bar and indicator to see that it is parallel with the table.
4. Clamp the tailstock in the proper position, depending upon the length of the work.
5. Line up the tailstock center with the headstock center.
6. Line up the cutter central with the dividing head or tailstock center.
Note.—When milling extremely steep helical angles, older Spiral Milling Attachments on Nos. 3 and 4 Dial Type Millers require 1" parallel blocks between the attachment housing and machine column to bring the cutter out to the center of the work.
7. Lock the saddle in position.
8. Swing the table to the correct angle. (Universal machine only.) If a Spiral Milling Attachment is being used on a plain machine, swing it to the correct angle.
9. Lock the housing in position. (Universal machine only.)
10. Withdraw the index plate stop (Fig. 35). The index plate must be free to revolve with the index pin. **Note**—The stop engaging the notches in the rim of the index plate should be engaged only when the Dividing Head is used without the driving mechanism.

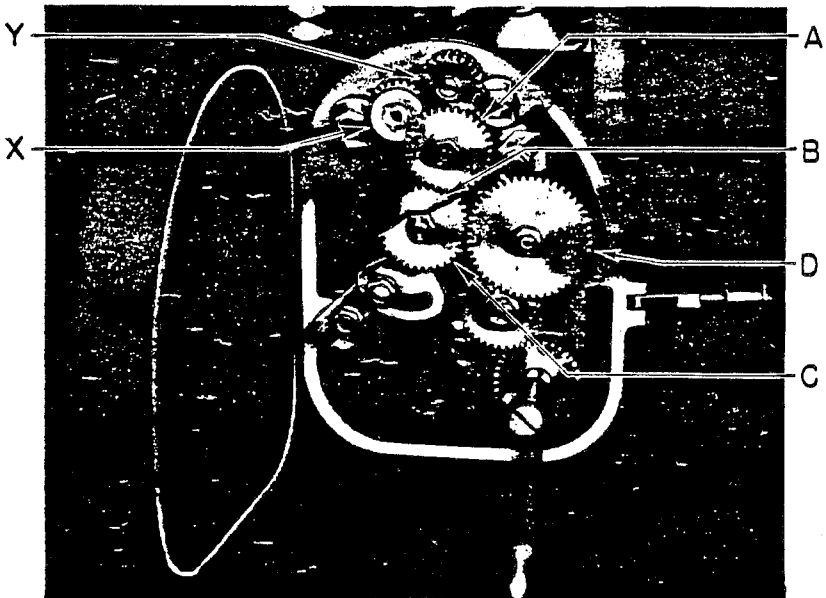

Figure 37
Dividing Head Driving Mechanism

11. Set up the change gears.
12. Set the index plate and sector for the proper spacing.
13. Oil the dividing head and change gears thoroughly.

Note a: With the Driving Mechanism connected to the Dividing Head, especially when the Head is equipped with a Wide Range Divider, (page 58) we do not recommend the use of the power rapid traverse to the table.

Note b: Be sure to set the table stop dog to the *left* of the arrow. See instructions "Setting Up the Driving Mechanism the First Time", page 80.

How to Select the Proper Change Gears. Suppose you want to cut a helix of $15\frac{1}{4}$ " lead. Consult the "Table of Leads" and find the lead which is nearest $15\frac{1}{4}$ —in this case 15.256. The change gears for this lead, 51, 18, 21 and 39, may be used, because the lead obtained is close enough to the lead desired for practical purposes.

You will notice that gear "C" is not listed for some leads. In such cases only one intermediate gear (B) is required, and a collar replaces gear "C"

Setting Up the Change Gear Segment. Remove the cone-shaped cover on the apron at the right-hand end of the table (Fig. 26, page 40). Then place the change gear segment on the apron, screw half-nuts on the two studs, and tighten them securely. Place the change gears in the positions indicated for the desired lead, being careful not to get gears B and C interchanged. The "hand" of the lead is fixed by gears X and Y, as shown in the table below.

After the set-up has been completed, move the table by means of the hand feed crank, to be sure that the entire mechanism operates freely, before engaging the power feed. Remove the hand crank and keep the cover closed while the machine is in operation.

	Right-Hand Helix	Left-Hand Helix
Dividing Head	Remove gear Y Reverse gear X	Gears X and Y, as shown in Fig. 37
12" and 16" Spiral Head	Gears X and Y, as shown in Fig. 37	Remove gear Y Reverse gear X

Calculating the Change Gears Required for a Given Lead. Many leads can be obtained other than those listed in the table. They were omitted because the difference was too small for ordinary requirements, but if you do not find a lead in the table which is close enough to meet your needs, the following formula will enable you to calculate all the possibilities.

$$\frac{\text{Lead}}{10} = \frac{\text{Driven}}{\text{Drivers}} = \frac{A \times C}{B \times D}$$

Suppose you want a lead of 35.789",

$$\frac{35.789}{10} = 3.5789, \quad \frac{51 \times 36}{27 \times 19} = 3.579$$

Gear A = 51 Teeth

Gear B = 27 Teeth

Gear C = 36 Teeth

Gear D = 19 Teeth

Standard change gears furnished with enclosed driving mechanism:

1 — 17 teeth	2 — 24 teeth	1 — 42 teeth
1 — 18 teeth	1 — 27 teeth	1 — 45 teeth
1 — 19 teeth	1 — 30 teeth	1 — 48 teeth
1 — 20 teeth	1 — 33 teeth	1 — 51 teeth
1 — 21 teeth	1 — 36 teeth	1 — 55 teeth
1 — 22 teeth	1 — 39 teeth	1 — 60 teeth

A few gear combinations can not be used (and, consequently, are not tabulated) because of interferences. For example, lead 36.090, gears 48-19-30-21.

Emergency Conversion to Short Leads. With the standard driving mechanism illustrated in Figure 37, leads lower than those listed in the tables, pages 100 to 116, can be obtained, using hand feed only (rotating the index crank at the side of the head). To change the gearing for low leads, remove gear "D". A 34 tooth gear is now exposed, meshing with the 34 tooth gear on the lead screw (directly below gear "D"). Remove these two 34 tooth gears, and replace them with the standard 51 tooth change gear on the lead screw and the standard 17 tooth change gear on the stud for gear "D". Instead of a 1 to 1 ratio, we now have a speed-up of 3 to 1. Leads for the change gear combinations listed are now divided by 3. **Caution:** Some of the change gear combinations are not obtainable because of interference with the segment.

This set-up should be used only for occasional jobs. If leads shorter than $2\frac{1}{2}$ " are cut often, we recommend the Long and Short Lead Attachment. Of course, this attachment can be installed only at our factory, as extra parts must be assembled into the saddle of the machine.

Leads Near the Low Range. When cutting leads within the low range of the Dividing Head driving mechanism, certain precautions should be observed. If, for example, the gears are set up for a 10" lead, the ratio of the change gears is 1 to 1, and the table feed (lead) screw rotates 40 revolutions to one revolution of the dividing head spindle.

For leads greater than 10", the dividing head spindle runs slower in relation to the speed of the lead screw. Example: 20" lead, table feed screw rotates 80 revolutions, while the dividing head spindle rotates one revolution. This requires a change gear set-up which *reduces* the speed from the lead screw to the dividing head, resulting in a mechanical advantage in transmitting power.

For leads shorter than 10", the dividing head spindle runs faster in relation to the speed of the lead screw. Example: 5" lead, table feed screw rotates 20 revolutions, while the dividing head spindle rotates one revolution. The change gear set-up for these low leads *increases* the speed from the lead screw to the dividing head, resulting in a mechanical disadvantage in transmitting power. The slow speed of the lead screw causes a "wind-up", which may produce a slightly jerky motion when milling short leads on large diameters of work. Therefore, conditions should be as nearly correct as possible when cutting short leads, particularly those from 2½" to 5". These conditions may be summarized in a few words. (a) the table gib should be correctly adjusted (not too tight), (b) the change gears should have a slight amount of back-lash, (c) the table ways and lead screw should be well oiled, (d) the table feed screw should rotate freely. Also, it might be noted that with a relatively high table feed, say 5¾" per minute, a greater proportion of power is available at the dividing head.

When all contributing factors are correct, the machine will pull a reasonable cut with a set-up for the lowest lead of 2½". If the cut should be unnecessarily heavy, then it is advisable to feed by hand. This may be done by allowing the table feed engaging lever to remain in neutral position and driving the dividing head and table by hand through the index crank in front of the index plate. With a short lead set-up hand feed is very easy, as the mechanical advantage is then in favor of the operator.

If leads lower than 5" must be cut often, we recommend our short lead mechanism. (It may be applied to Universal machines only.) Then leads as low as .010" may be cut by power.

Rapid Traverse and High Feed Rates. When the driving mechanism is set up for low leads, *do not* engage the table rapid traverse, or use high feed rates of 11" or 16" per minute. Such rapid rates of table traverse drive the dividing head too fast, resulting in rapid wear or perhaps "freezing" of the dividing head spindle in the block, as they are fitted very closely to obtain accuracy in spacing.

How to Calculate the Angle for Setting the Spiral Milling Attachment. Suppose you want to mill a lead of $7\frac{1}{2}$ " on a 3" diameter *work-piece. The angle for swiveling the attachment is not shown for this combination, but it can be calculated very easily from the following formula:

$$\text{Tangent of angle} = \frac{3.1416 \times \text{diameter}}{\text{lead}}$$

$$\text{In the above example, Tan. angle} = \frac{3.1416 \times 3}{7.5} = 1.2566$$

$$\text{Angle} = 51\frac{1}{2}^\circ \text{ (See table, page 121.)}$$

How to Calculate Indexing with the Side Plate. (Standard Dividing Head). In case a particular circle of holes on the index plate becomes worn through constant use, you may be able to use some other circle of holes and get the same result. The following set of rules and example illustrate the procedure to follow in obtaining the maximum number of settings for any condition of indexing. Since the ratio between the worm and worm-wheel in the Cincinnati Dividing Head is 40 to 1, then:

1. Divide 40 by the number of divisions required. The result gives the number of turns or fraction of a turn of the index pointer.
2. If a fraction of a turn is required, the denominator (the lower part of the fraction) represents the circle to use, while the numerator represents the number of spaces in the circle over which the index pin must pass.
3. Reduce the fraction to its lowest terms, and multiply both parts of the fraction by the same number until the denominator equals the number of holes in any circle.

Standard Dividing Head Plate—Number of holes for indexing: 24, 25, 28, 30, 34, 37, 38, 39, 41, 42 and 43 on one side; 46, 47, 49, 51, 53, 54, 57, 58, 59, 62 and 66 on other side.

Example

Suppose you want to calculate all the indexing circles for 3 divisions

$$\frac{40}{3} = 13 \frac{1}{3} \text{ turns of the index pointer.}$$

*Note: Use pitch diameter in calculating helix angle for helical and spiral gears, worms, etc.

One-third of a turn could be obtained by rotating the index pin over one space in a 3 division circle—(Rule 2). Since we do not have a 3 hole circle, we must use one into which the number of holes can be evenly divided by 3. For instance, 8 spaces in the 24 hole circle, ($8/24 = 1/3$), 10 spaces in the 30 hole circle ($10/30 = 1/3$), etc. One-third of a turn can be obtained in any of the following circles:

$\frac{1}{3} \times 8 = \frac{8}{24}$	or	8 spaces in the 24 hole circle.
$\frac{1}{3} \times 10 = \frac{10}{30}$	" 10	" " " " 30 " "
$\frac{1}{3} \times 13 = \frac{13}{39}$	" 13	" " " " 39 " "
$\frac{1}{3} \times 14 = \frac{14}{42}$	" 14	" " " " 42 " "
$\frac{1}{3} \times 17 = \frac{17}{51}$	" 17	" " " " 51 " "
$\frac{1}{3} \times 18 = \frac{18}{54}$	" 18	" " " " 54 " "
$\frac{1}{3} \times 19 = \frac{19}{57}$	" 19	" " " " 57 " "
$\frac{1}{3} \times 22 = \frac{22}{66}$	" 22	" " " " 66 " "

Example

Suppose you want to calculate all the indexing circles for 56 divisions.

$\frac{40}{56} = \frac{5}{7}$ of a turn of the index crank.

$\frac{5}{7} \times 4 = \frac{20}{28}$	or	20 spaces in the 28 hole circle.
$\frac{5}{7} \times 6 = \frac{30}{42}$	" 30	" " " " 42 " "
$\frac{5}{7} \times 7 = \frac{35}{49}$	" 35	" " " " 49 " "

Angular Indexing. Tables for angular indexing with the standard and high number index plates are not tabulated in this book because they are little used as compared to numerical divisions. However, angular spacing can readily be calculated, keeping in mind that one complete turn of the index crank = 9° , one space in the 30 hole circle = $18'$, and one space in the 54 hole circle = $10'$. The tabulation at the right shows the angular movement of the Dividing Head spindle for a movement of the index crank of one space in the various hole circles.

Circle	One Space	Circle	One Space
24	22' 30"	46	11' 44"
25	21' 36"	47	11' 29"
28	19' 17"	49	11' 1"
30	18' 0"	51	10' 35"
34	15' 53"	53	10' 11"
37	14' 36"	54	10' 0"
38	14' 13"	57	9' 28"
39	13' 51"	58	9' 19"
41	13' 10"	59	9' 9"
42	12' 51"	62	8' 43"
43	12' 33"	66	8' 11"

Plain Indexing with the Front Plate. Direct indexing is often used for making the divisions listed in the following table because it is faster than indexing with the side plate through the 40 to 1 worm reduction. To change the dividing head into plain index centers, turn the eccentric for disengaging the worm (Fig. 38) through half a turn. The worm is then disengaged and indexing is accomplished by turning the spindle by hand.

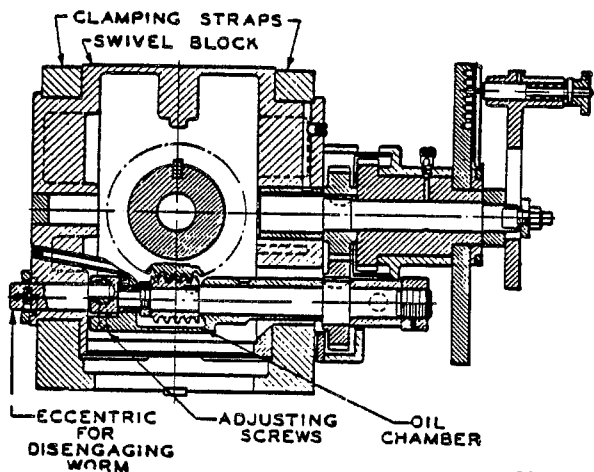

Figure 38
Section Through Dividing Head
Showing Worm

PC-267

The front plate (Fig. 39) is drilled with three circles of holes: 24, 30, and 36. It will index any number which divides evenly into any one of these numbers of holes in a circle. When changing from plain indexing back to universal indexing through the side plate, it is important that the front index pin be locked in its "out" position.

Indexing with the Front Plate

Divisions	Circles	Spaces	Divisions	Circles	Spaces	
2	24	12	8	24	3	
	30	15	9	36	4	
	36	18	10	30	3	
3	24	8	12	24	2	
	30	10		36	3	
	36	12		30	2	
4	24	6	15	30	2	
	36	9	18	36	2	
	5	30	6	24	24	1
30				30	1	
36				36	1	
6	24	4	36	36	1	
	30	5		36	36	1
	36	6				

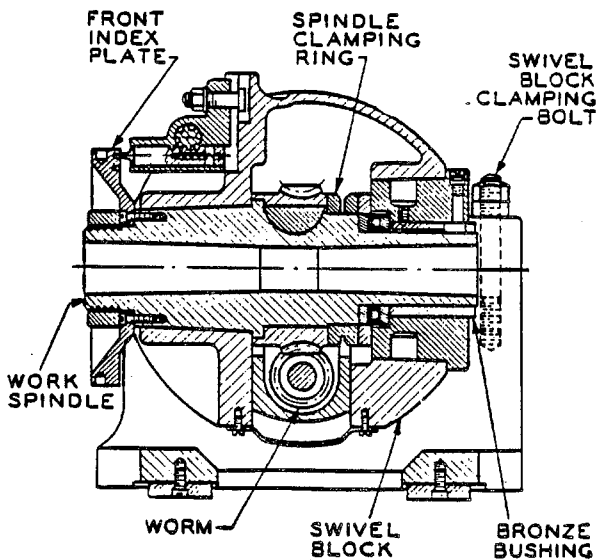

Figure 39
Section Through Dividing Head
Showing Front Plate

Clamping the Dividing Head Spindle in Place. The spindle should be clamped in place (except when milling helices) during heavy cutting operations to relieve all strains on the worm, worm-wheel, and index pin. (Fig. 40.) Screw "A" forces wedge "B" into split ring "C", firmly clamping the spindle in place. Be sure to unclamp the spindle before turning the index crank or engaging the table feed while the head is set up for milling helices.

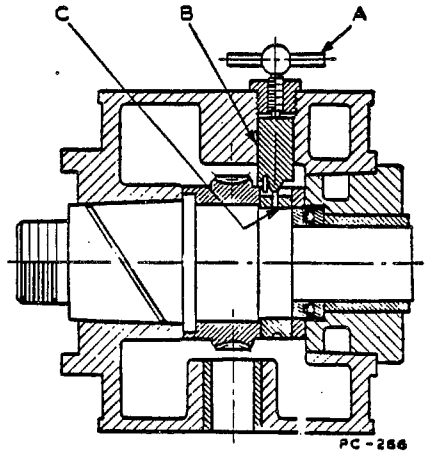

Figure 40
Section Through Dividing Head
Showing Spindle Clamp

Adjusting the Dividing Head Worm. Wear between the worm and worm-wheel may be eliminated in the following manner:

1. See that the worm is engaged with the worm-wheel (Fig. 38).
2. Remove the back-lash from the worm by tightening the locknut on the end of the worm shaft (Fig. 38).
3. Remove the cover from the bottom of the swivel block (Fig. 41).
4. Release fillister head screws "A-A", turn both set screws "B-B" the same amount in a counter-clockwise direction, and then retighten screws "A-A".
5. Turn the dividing head spindle by hand to see that it rotates freely with no evidence of back lash, and then replace the cover.

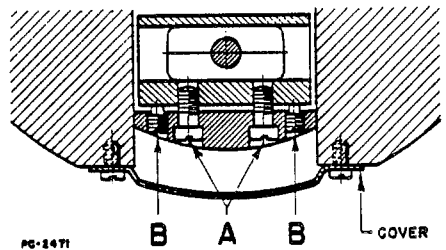

Figure 41
Section Through Worm Adjustment

THE WIDE RANGE DIVIDER

The Wide Range Divider applied to a Cincinnati Universal Dividing Head enables you to obtain divisions from 2 up to 400,000. It consists of large index plate "A", sector and crank "B", together with a small index plate "C", and sector and crank "D". The mechanism is so arranged that crank "D" operates through reduction gearing of 100 to 1 ratio enclosed in housing "G". The ratio between the worm shaft and the spindles is 40 to 1.

Set up for indexing in the conventional manner. The divisions given in the table (page 95) can be obtained by utilizing crank "B" only in combination with the proper hole circle on the large plate. (Large plate drilled on both sides and contains 11 circles of holes on each side). The index pin in crank "B" can be swiveled to any hole circle. When indexing in this conventional manner, the operation is exactly the same as it is on the regular Cincinnati Dividing Heads.

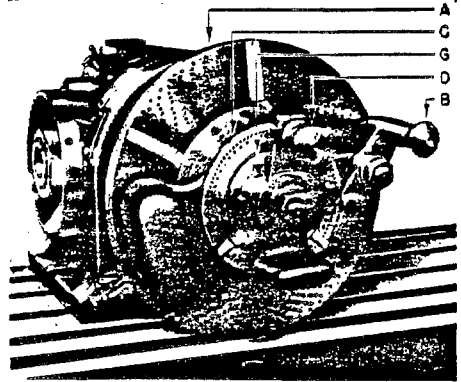

Figure 42
Wide Range Divider

How to use the Wide Range Divider. Any whole number of divisions, up to and including 60, and hundreds of others, can be obtained with the large plate only, and the setting may be read directly from the table, page 95. If the number of divisions required is not listed in the table, calculate the setting in the following manner.

Set-up

- *1. Divide 400,000 by the number of divisions desired, for example 67. The result gives you a whole number quotient and a fraction— $5970\frac{10}{67}$.
2. Adjust cranks "B" and "D" to the 100-hole circle on their respective plates.
3. Set the sector on large index plate "A" for 59 spaces on the 100-hole circle, 59 being the first two whole numbers of the quotient obtained.
4. Set the sector on the small index plate "C" for 70 spaces on the 100-hole circle, 70 being the last two whole numbers of the quotient obtained.

***Note:** Should the quotient be a five-digit number, the first number represents the number of full turns of crank "B". (No five-digit quotient appears when making divisions higher than 40, and furthermore, calculations are unnecessary for any number less than 61.)

Operation

5. Index crank "B" an amount equal to the sector setting, namely—59 spaces.
6. Then index crank "D" an amount equal to the sector setting, namely—70 spaces. (Both cranks are moved in the same direction.)

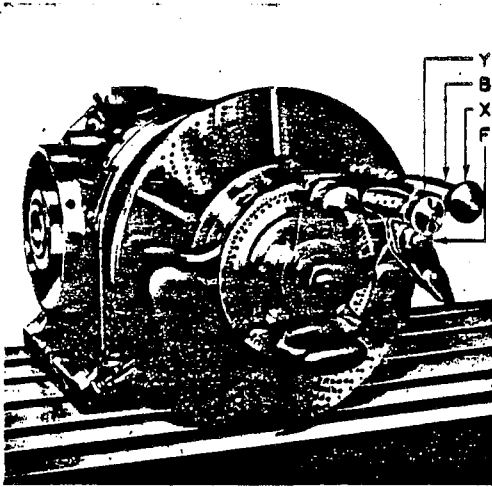

Figure 43

When indexing in the conventional manner (divisions tabulated on page 95), index crank "B" may be changed to a different circle of holes, as from "X" to "Y", by merely loosening nut "F"

7. Compensate for fraction 10/67 by adding one space to the index movement of the small crank "D" at intervals equal to the nearest whole number obtained by dividing 1 by 10/67. The result of this division is 7. Therefore, every seventh division, index 71 spaces on the small plate "C" instead of 70. In this way you pick up the fractional remainder, and the maximum error is equal to only .0000942" on a 12" diameter circle (the movement of one space in the 100-hole circle on the small plate.)

Angular Spaced Divisions. If the divisions are spaced in degrees, minutes, and seconds, the procedure in calculating the setting is very similar to that outlined above, except that for sake of convenience, use the 54-hole circle on both plates. Complete tables are listed on pages 98 and 99.

Using crank B on the large plate (Figs. 42 and 43):

- (a) One complete turn is equivalent to 9 degrees.
- (b) Six spaces in the 54-hole circle equals 1 degree.
- (c) One space in the 54-hole circle equals 10 minutes.

Using crank D on the small plate:

- (a) One complete turn of crank "D" equals 5 minutes and 24 seconds
- (b) Ten spaces in 54-hole circle equals 1 minute.
- (c) One space in 54-hole circle equals 6 seconds.

Example. Indexing an Angle of 3 Degrees, 20 Minutes, 12 Seconds.

Set-up

1. Consulting the "Degree" table on page 98, set the sector on index plate "A" (Fig. 42) for 18 spaces on the 54-hole circle.
2. Consulting the "Fractions of a Degree" table on page 99, set sector "G" on plate "C" for 40 spaces on the 54-hole circle.

Operation

1. Index large crank "B" (Fig. 42) an amount equal to the sector setting, namely 18 spaces.
2. Index small crank "D" three turns (see table) plus the sector setting, namely 40 spaces. (Both cranks are moved in the same direction.)

Adjusting the Index Pin on the Small Plate. The index pin in the crank for the small plate is eccentric to provide a method of adjusting the pin from the 100-hole to the 54-hole circle, and vice-versa. Merely loosen screw E, (Fig. 44), rotate the pin to the desired circle of holes, and then retighten the screw.

Reversing the Large Index Plate (Wide Range Divider). If the set-up requires the reversal of the large index plate, the operation may be accomplished in the following manner:

1. Remove nut "A" and the washer behind it. (Fig. 44).
2. Slip differential unit "B" off the shaft.
3. Sector "C" is now free and may be removed.
4. Remove four screws "D", reverse the plate, and reassemble the parts.

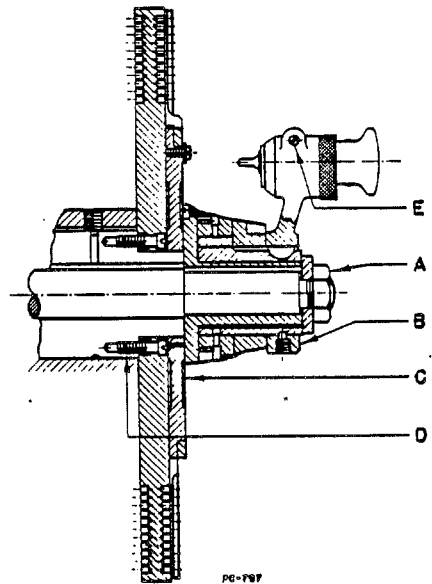

Figure 44
Section Through Differential
Mechanism

MILLING CAMS

Rise and fall cams having a relatively narrow face may be machined by using the type of set-up indicated in Figure 45. The cutter may be supported in any type of swiveling head, such as a Universal Spiral Milling Attachment or Heavy Vertical Attachment. Almost any cam lead can be machined, and by trying different machine leads, the angle to which the dividing head must be set can be changed to suit conditions. All you need in addition to this instruction book is a table of sine functions.

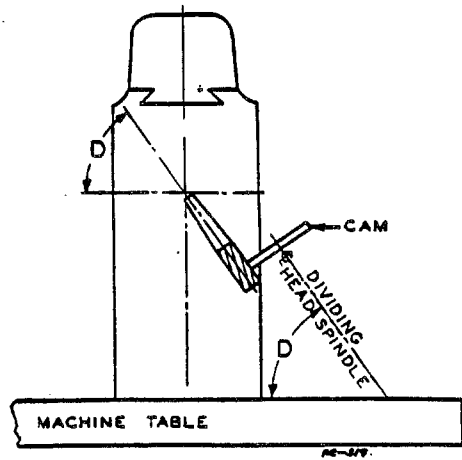

Figure 45
Diagrammatic Sketch of Dividing Head Set Up for Milling Cams

Formula: $\frac{\text{Lead of Cam}}{\text{Lead of Table}} = \text{Sine of Angle "D"}$

Examples:

- Suppose you want to mill a cam having a .500" lead. Assume change gears are set up for 2.5" table lead.

$$\frac{\text{Lead of Cam}}{\text{Lead of Table}} = \frac{.5}{2.5} = .200; \text{ sine of angle "D"}$$

$$\text{"D"} = 11 \text{ degrees, } 33 \text{ min.}$$

- Suppose you want to mill a lead of 6.005".
 - Assume change gears are set up for 8" table lead

$$\frac{\text{Lead of Cam}}{\text{Lead of Table}} = \frac{6.005}{8} = .7506; \text{ Angle "D"} = 48 \text{ degrees, } 39 \text{ min.}$$

- Assume change gears are set up for 9.935" table lead, instead of 8", as in example 2a, then

$$\frac{6.005}{9.935} = .6044; \text{ and Angle "D"} = 37 \text{ degrees, } 11 \text{ min.}$$

BACKLASH ELIMINATOR

There are two distinct methods of milling: (a) conventional, or up-milling, Fig. 46, and (b) climb or down-milling, Fig. 47. The forces created in up-milling tend to lift the part up into the cutter and spring the cutter down into the work. In down milling, the cutter has a tendency to spring away from the work and at the same time, push the work down against its supporting surface. In up-milling, the thickness of the chip increases uniformly from zero at the bottom (beginning) of the cut to a maximum

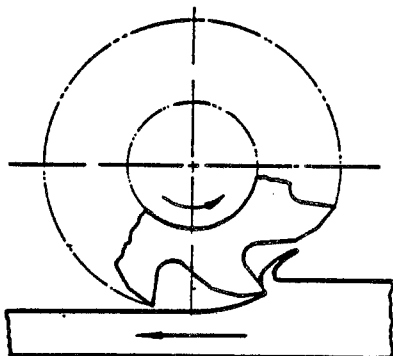

PC-334

Figure 46
Conventional, or Up-Milling

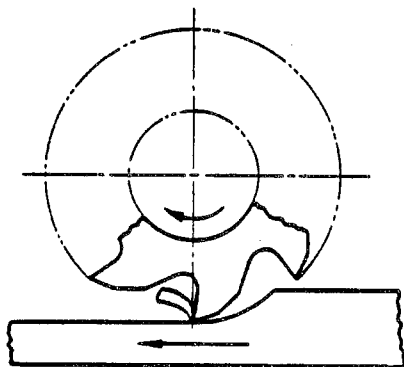

Figure 47
Climb, or Down-Milling

at the top of the cut, while in down-milling, the chip thickness decreases uniformly from a maximum at the top (beginning) of the cut to zero at the bottom (end) of the cut (Figs. 46-47). Although the majority of milling operations can be done either way, down-milling produces the better results on thin parts which are difficult to hold; exceptionally wide cuts; or thin deep cuts as when sawing slots.

The backlash eliminator device, shown diagrammatically in Fig. 48, is required for down-milling operations, and may be purchased at extra cost with the machine. It is entirely within the saddle beneath the table, the only indication being knob "G" at the front of the saddle casting (Fig. 49).

When the machine is equipped with a backlash eliminator, either down-milling or up-milling operations can be handled. During up-milling cuts or when rapid traversing, the backlash eliminator is automatically released. However, in down-milling, as soon as the cutter contacts the work, the backlash between the nut and the lead screw is automatically taken up.

The following description applies specifically to the backlash eliminator for plain and vertical machines, although the theory applies equally well to universal machines. The device consists essentially of two nuts, "A" and "B", freely mounted on the table lead screw. The crown teeth on gear "E" mesh with the gear teeth on nuts "A" and "B". Therefore, when one nut rotates, the other nut will also rotate but in the opposite direction. The spur gear teeth on gear "E" mesh with rack "D".

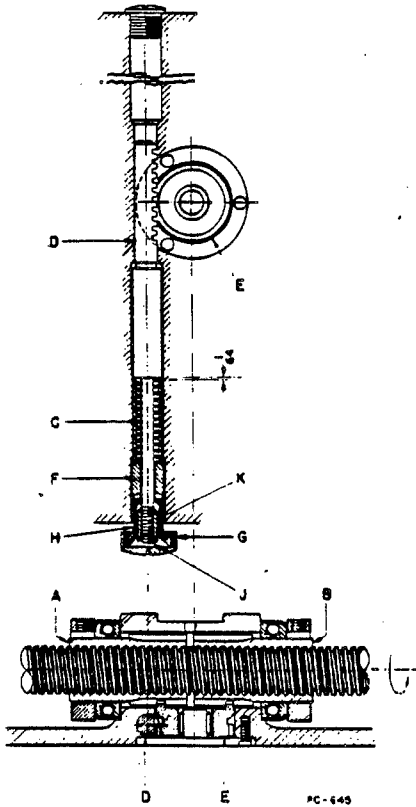

Figure 48
Backlash Eliminator for
Nos. 3 and 4 Universal
and all
Plain and Vertical Machines

Spring "C", contained within sleeve "F", tends to push in rack "D", rotating crown gear "E" and nuts "A" and "B" a sufficient amount to eliminate the backlash. Threaded sleeve "F" serves two purposes: (a) to provide adjustment, and (b) to provide a stop for the outward movement of the rack.

Operation of Backlash Eliminator (All machines except No. 2 Universal). Suppose we consider in detail the table movement to the right. Actually, the same discussion may be applied to either direction of travel. When the lead screw (it has a right hand thread) rotates in the direction indicated in the illustration, the table moves to the right. The resulting thrust and friction on nut "B" causes it to rotate in the same direction as the lead screw, thereby rotating nut "A" in the opposite direction, which, in turn, pushes plunger "D" out against sleeve "C" and relieves the spring pressure.

If an up-milling cut is being taken or if the table is rapidly traversed to the right, obviously the reaction on nut "B" is the same as explained above, and no change will take place in the position of nuts "A" and "B".

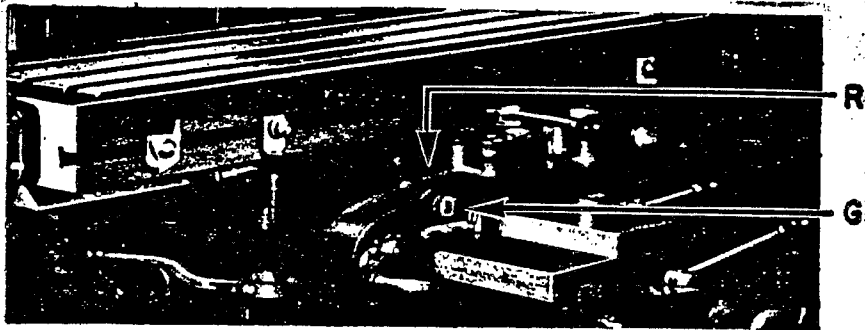

Figure 49
Front View of Saddle, Showing Backlash Engaging Knob

On the other hand, if the cutter is rotating with the feed of the table, as in "Down Milling", as soon as the cutter engages the work, the thrust will shift from nut "B" to nut "A". The frictional torque between nut "A" and the lead screw is thereby increased, and consequently, nuts "A" and "B" will rotate in the direction which will preload the ball bearings. This action immediately eliminates the backlash between the screw and the nut. As soon as the "Down Milling" load is removed, nuts "A" and "B" are brought back to the initial conditions by the thrust of the table which now acts on nut "B".

Adjusting the Backlash Eliminator (All machines except No. 2 Universal). There should be no need to adjust the backlash eliminator unless previously mis-adjusted or dismantled. If necessary to adjust the device proceed in the following manner, with the machine stopped.

1. Adjust the table feed screw bearings, page 40.
2. Loosen set screw "R", Figure 49.
3. Remove cap "G", screw "H", lock screw "J", and nut "K", Fig. 48.
4. Push in rack "D". While holding it in position, adjust sleeve "F" until tight against the shoulder of the rack, then back it away about $1\frac{1}{2}$ revolutions or slightly less.
5. Retighten screw "R".
6. Replace parts "K", "J", "H", and "G".

Properly adjusted, rack "D" should move out about $\frac{1}{64}$ " when the table feed or rapid traverse is engaged in either direction. This can be observed by removing cap "G" and engaging the table feed and rapid traverse levers. Also, with the backlash device engaged, the table should move snugly with the hand crank.

Engaging and Disengaging the Backlash Eliminator (All machines except No. 2 Universal). To engage, turn knurled cap clockwise (right) as far as it will go; to disengage, turn cap counterclockwise (left).

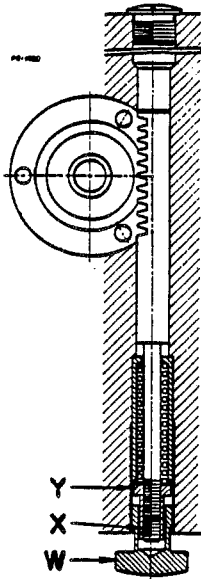

Figure 50
Backlash Eliminator for
No. 2 Universal Machines only

Backlash Eliminator (No. 2 Universal Machines). Because of basic design characteristics, the backlash device for No. 2 Universal Machines is slightly different than the one described in the preceding paragraphs. Note that the rack operates on the right-hand rather than the left-hand side of the crown gear. This results in movements exactly opposite to those of the rack in plain machines.

Adjusting the Backlash Eliminator (No. 2 Universal Machines).

1. Adjust the table feed screw bearings, page 40.
2. Remove knurled cap "W", Figure 50.
3. Remove socket head screw "X".
4. Tighten nut "Y" all the way, then back off about 1½ revolutions.
5. Replace socket head screw to lock nut in place.
6. Replace knurled cap.

Engaging and Disengaging the Backlash Eliminator (No. 2 Universal Machines). Whether engaging or disengaging the backlash device, turn knurled cap "W" as far as it will go. To engage, turn knurled cap counter-clockwise (left); to disengage, turn cap clockwise (right).

ACCESSORIES AND ATTACHMENTS

ARBORS—"50" Spindle Series

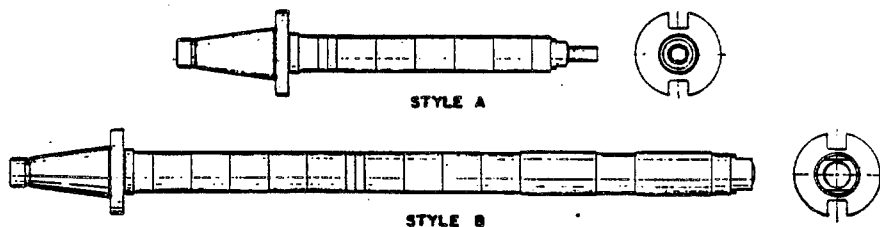

Figure 51—Conventional Milling Machine Arbors

Catalog Number	Diameter	Style	Usable Length of Cutter Space	Diameter of Bearing Collar	Keyway		Code Name
					Width	Depth	
* 50- $\frac{3}{8}$ A10	$\frac{3}{8}$	A	10	None			TENAR
*50-1 A12	1	A	12	None	$\frac{1}{4}$	$\frac{1}{8}$	ARTWA
50-1 A15	1	A	15	None	$\frac{1}{4}$	$\frac{1}{8}$	ARBAA
50-1 A18-4	1	A	18	$2\frac{1}{8}$	$\frac{1}{4}$	$\frac{1}{8}$	ATARB
50-1 B24-4	1	B	24	$2\frac{1}{8}$	$\frac{1}{4}$	$\frac{1}{8}$	ARBFA
*50-1 $\frac{1}{4}$ A12	$1\frac{1}{4}$	A	12	None	$\frac{1}{4}$	$\frac{1}{8}$	ARBCO
50-1 $\frac{1}{4}$ A15	$1\frac{1}{4}$	A	15	None	$\frac{1}{4}$	$\frac{1}{8}$	AROGU
50-1 $\frac{1}{4}$ A18-4	$1\frac{1}{4}$	A	18	$2\frac{1}{8}$	$\frac{1}{4}$	$\frac{1}{8}$	ARBURU
50-1 $\frac{1}{4}$ B18-4	$1\frac{1}{4}$	B	18	$2\frac{1}{8}$	$\frac{1}{4}$	$\frac{1}{8}$	BETAR
50-1 $\frac{1}{4}$ B24-4	$1\frac{1}{4}$	B	24	$2\frac{1}{8}$	$\frac{1}{4}$	$\frac{1}{8}$	ONARB
50-1 $\frac{1}{2}$ B18-4	$1\frac{1}{2}$	B	18	$2\frac{1}{8}$	$\frac{3}{8}$	$\frac{1}{8}$	HAFAR
50-1 $\frac{1}{2}$ B24-4	$1\frac{1}{2}$	B	24	$2\frac{1}{8}$	$\frac{3}{8}$	$\frac{1}{8}$	FORRA
50-1 $\frac{1}{2}$ B30-4	$1\frac{1}{2}$	B	30	$2\frac{1}{8}$	$\frac{3}{8}$	$\frac{1}{8}$	ARBTY
50-1 $\frac{1}{2}$ B36-4	$1\frac{1}{2}$	B	36	$2\frac{1}{8}$	$\frac{3}{8}$	$\frac{1}{8}$	ARCOB
**50-2 B24-5	2	B	24	$2\frac{3}{4}$	$\frac{1}{2}$	$\frac{1}{8}$	ARJYN
**50-2 B30-5	2	B	30	$2\frac{3}{4}$	$\frac{1}{2}$	$\frac{1}{8}$	TUBAR
**50-2 B36-5	2	B	36	$2\frac{3}{4}$	$\frac{1}{2}$	$\frac{1}{8}$	ARCOD

**Includes two suitable bushings for $2\frac{3}{4}$ " diameter bearing collars.

*Arbors 50- $\frac{3}{8}$ A10, 50-1A12, 50-1 $\frac{1}{4}$ A12 require the use of arbor support bushing adapter (Catalog Number 50-M-01) when used on Nos. 3 and 4 Machines.

SHELL END MILL ARBORS—Style C

Catalog Number	Diameter Range of End Mills	Stud Diameter	Code Name
50- $\frac{1}{2}$ C $\frac{3}{8}$	$1\frac{1}{4}$ — $1\frac{1}{2}$	$\frac{1}{2}$	SHEMA
50- $\frac{3}{4}$ C $\frac{3}{8}$	$1\frac{3}{4}$ —2	$\frac{3}{4}$	SEMCO
50-1 C $\frac{7}{8}$	$2\frac{1}{4}$ — $2\frac{1}{2}$ — $2\frac{3}{4}$	1	SHEPU
50-1 $\frac{1}{4}$ C $\frac{7}{8}$	3— $3\frac{1}{2}$	$1\frac{1}{4}$	SHEHI
50-1 $\frac{1}{2}$ C $\frac{7}{8}$	4— $4\frac{1}{2}$ —5	$1\frac{1}{2}$	SHEBY
50-2 C $\frac{7}{8}$	$5\frac{1}{2}$ —6	2	SEMOR

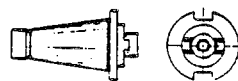

STYLE C

Figure 52
Shell End Mill Arbor

Chrome nickel heat-treated screws for holding shell end mill on arbor are furnished with all arbors. Wrenches are furnished with arbors 50-1 $\frac{1}{4}$ C $\frac{7}{8}$, 50-1 $\frac{1}{2}$ C $\frac{7}{8}$ and 50-2C $\frac{7}{8}$.

Always Order Arbors by the Code Name and Catalog Number

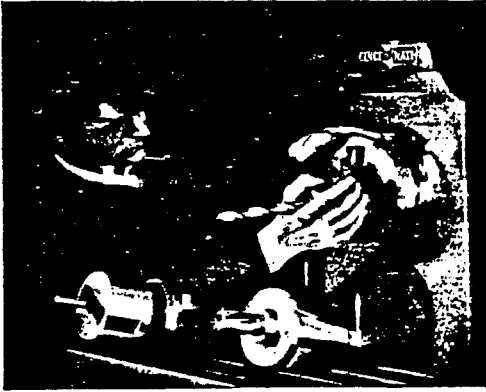

QUICK CHANGE ADAPTER

Catalog No. NS-H5

Code Word—ADACO

Complete attachment consists of: Nut, Slotted Key, Stop Lug, Spanner Wrench, Screw for Slotted Key, Ring, Four Screws, and Socket Wrench.

Figure 53

With the Quick Change Adapter, Cutters May be Changed in a Few Seconds

QUICK CHANGE COLLETS
(Include Draw-in Bolt)

Catalog Number	Inside Taper	Code Name
50NS—FEB 7	No. 7 B. & S.	COQUI
50NS—FEB 9	No. 9 B. & S.	COSEM
50NS—FEB 10	No. 10 B. & S.	COSBE
50NS—FEB 11	No. 11 B. & S.	COTTO
50NS—FEM 2	No. 2 Morse	CORIC
50NS—FEM 3	No. 3 Morse	COROB
50NS—FEM 4	No. 4 Morse	CODDE

QUICK CHANGE SHELL END MILL ARBORS

Catalog Number	Diameter Range of End Mills	Stud Diam.	Code Name
50- 1/2 FC 1/2	1 1/4—1 1/2	1/2	ARABB
50- 3/4 FC 3/4	1 3/4—2	3/4	ARDUI
50-1 FC 1	2 1/4—2 1/2—2 3/4	1	ARSHE
50-1 1/4 FC 1 1/4	3—3 1/2	1 1/4	ARTTA
50-1 1/2 FC 1 1/2	4—4 1/2—5	1 1/2	ARICK
50-2 FC 2	5 1/2—6	2	AREMI

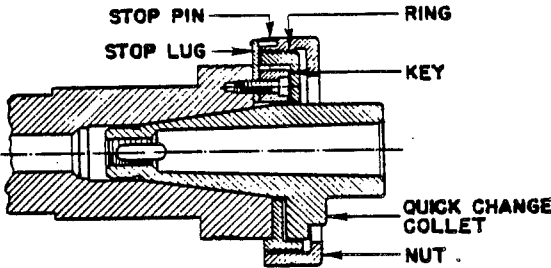

SECTION A-B

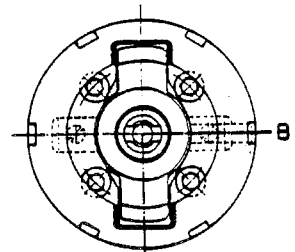

PC-1088

Figure 54

Section Through Quick Change Adapter

Instructions for Mounting Quick Change Adapter on Spindle Nose

Note—Right-hand, left-hand, and clockwise are referred to as when facing the spindle nose.

1. Rotate the spindle until the driving keys line up parallel with the table. Remove the right-hand key, and insert in its place the special key and stop lug, with the long end of the stop lug extending beyond the circumference of the spindle. (See sketch, Fig. 54.)

2. Assemble the nut on the ring by screwing these two parts together. The rear face of the ring (with the 1" wide slots) should be approximately flush with the rear face of the nut, and at the same time the key openings in these two parts should match.
3. Place the ring and nut as assembled in step No. 2 on the face of the machine spindle, with the stop pin directly below the stop lug. The nut can now be turned from this position in a clockwise direction only.
4. Now fasten the assembly, as described in step No. 3, to the spindle nose with the four hollow hexagon head screws which are furnished with the complete adapter. In order to accomplish this, turn the nut as required so that the screws can be inserted.
5. The quick change adapter is now ready for use. The operations are as follows:
 - a. Turn the adapter nut counter-clockwise until the stop pin hits the stop lug.
 - b. Insert the quick change arbor or collet, as the case may be.
 - c. Turn the nut clockwise and fasten with a spanner wrench.

QUICK CHANGE FACE MILL ARBOR

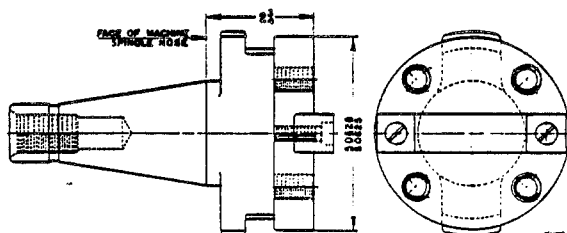

Figure 55
Sketch of quick change face mill arbor. For face mills 7" to 12" diameter.

Catalog No. 50-51 1/8 FC
Code Name. ARFAC

COLLET ADAPTER

Reducing No. 50 to No. 40 Spindle Series

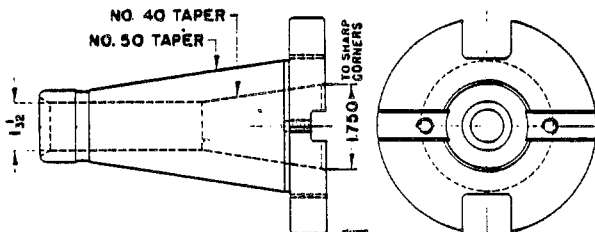

Figure 56

Arbors and cutters having No. 40 series standard taper shanks may be used on Dial Types with the above adapter.

Outside Taper. No. 50 Milling Machine Standard

Inside Taper. No. 40 Milling Machine Standard

Catalog No. 50-NS-40

Code Name — COAFD

HIGH NUMBER INDEXING ATTACHMENT

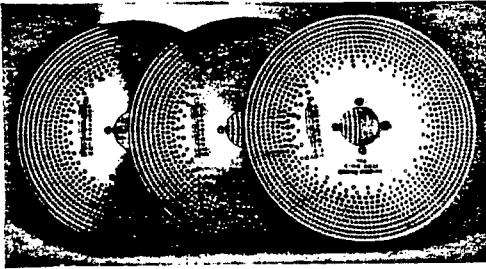

Figure 57
High Number Indexing Attachment

This attachment, shown in Figure 57, consists of three plates, drilled on both sides. These plates are interchangeable with the standard index plate on the side of the head. Those for the standard Dividing Head may also be applied to Spiral Milling Heads and Gear Cutting Attachments.

High Number Index Plates are also available for the Wide Range Divider. These are recommended only where the compensating feature is objectionable for numbers below 200.

The index table shown on pages 96-97, apply to the High Number Indexing Attachment Plates tabulated below.

Number of Holes Drilled in Each Side of High Number Index Plates

For Standard Dividing Head					
Part No. 10525		Part No. 10526		Part No. 10527	
For Wide Range Divider					
Part No. 113505		Part No. 113506		Part No. 113507	
Side A	Side B	Side C	Side D	Side E	Side F
189	199	197	193	191	187
177	183	181	179	175	173
171	169	167	163	161	159
147	157	153	151	149	143
129	141	139	137	133	131
117	127	123	121	119	113
99	111	109	107	103	101
91	97	93	89	87	83
69	81	79	77	73	71
48	67	46	44	42	38
30	36	34	32	26	28

COMPENSATING DOG AND DRIVER

The Compensating Dog and Driver, Fig. 58, may be used with CINCINNATI Dividing Heads and Gear Cutting Heads. With these driving elements, greater accuracy will be obtained on taper work. The tail of the dog has a close fitting roller, which, in turn, fits into the slot of the driver. As the work is indexed, the roller slides on the tail of the dog a sufficient amount to compensate for the varying difference in the distance from the center of the work to the point of driving contact. The dog has a capacity range from $\frac{1}{4}$ " to $2\frac{3}{4}$ " diameter.

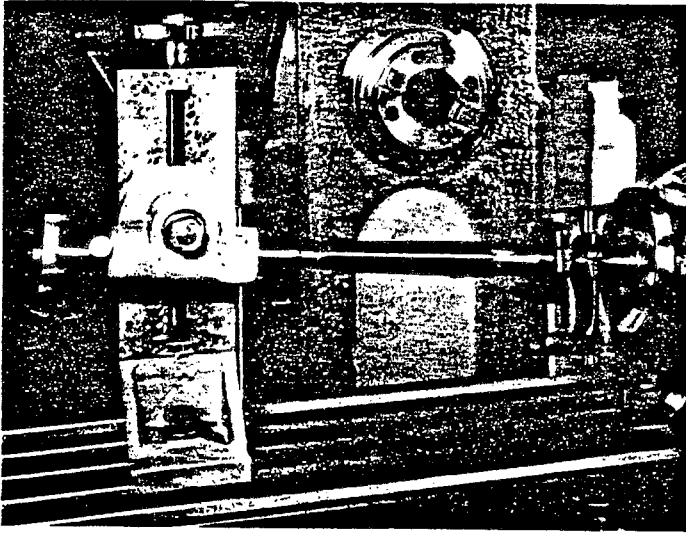

Figure 58
High Tailstock (Left) and Compensating Milling Machine Dog and Driver

HIGH TAILSTOCK

If the work has a steep angle taper and is relatively long, the High Tailstock illustrated in Fig. 58 may be used to advantage. The bracket carrying the center is graduated, and can be set at the same angle as the work.

Maximum distance, table to center point— $11\frac{1}{2}$ "

Minimum distance, table to center point— $3\frac{1}{2}$ "

RAISING BLOCKS

Raising blocks, one of which is illustrated in Fig. 59, may be placed under the Dividing Head and Tailstock to obtain an increase in range. These blocks are flat, parallel, and of equal height, (supplied only in matched pairs) and give the head and tailstock a substantial support.

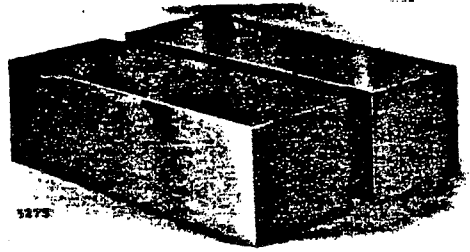

Figure 59
Raising Block

SPECIFICATIONS

Size Head	Height of Blocks	Width T-Slots	Headstock Block		Tailstock Block	
			Length	Width	Length	Width
12"	2 1/2"	3/8"	12 3/8"	9 1/4"	6 5/8"	6 1/8"
14"	2"	3/8"	12 3/8"	9 1/4"	6 5/8"	6 1/8"

ANGLE PLATE

Angle Plates, illustrated in Fig. 60, are convenient for many types of set-ups involving a Dividing Head or small fixture placed off-center or at an angle to the table T-slots. The T-slots are standard size and at right angles to each other.

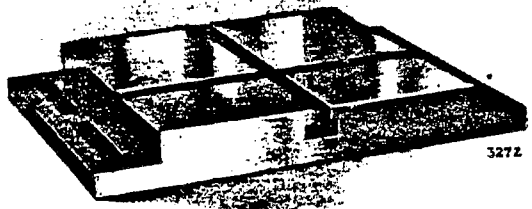
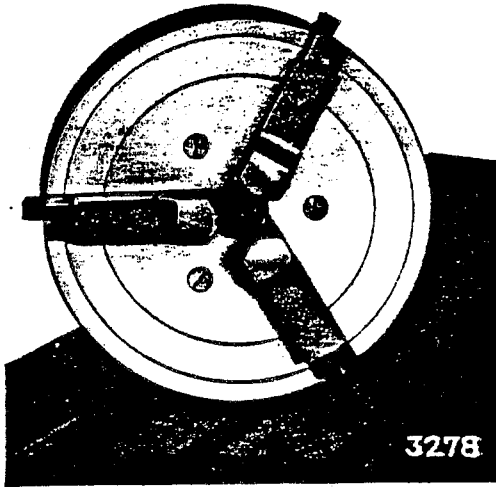

Figure 60
Angle Plate

SPECIFICATIONS

Size Head	Height of Plate	Width T-Slot	Working Surface	Size Over All
12"	2 1/8"	3/8"	12 1/2" x 12 3/8"	12 1/2" x 16 3/8"
14"	2 1/8"	3/8"	12 1/2" x 12 3/8"	12 1/2" x 16 3/8"



CHUCK

Many Dividing Head jobs can be more conveniently held in a chuck than between centers. To facilitate this class of work, the 3-Jaw Universal Chuck, illustrated in Fig. 61, may be obtained. It has a threaded flange for mounting it on the spindle nose of the head.

Figure 61
Dividing Head Chuck

SPECIFICATIONS

Size Head	Size Chuck	Capacity	Outside Diameter	Thread
10" Dividing	6"	$\left. \begin{array}{l} \frac{1}{4}" \text{ to } 2\frac{3}{4}" \\ \text{outside grip} \\ \frac{1}{4}" \text{ to } 3\frac{1}{2}" \\ \text{inside grip} \end{array} \right\}$	6 $\frac{1}{4}"$	2" —8 thd.
12" and 14" Dividing, 12" Spiral	9"	$\frac{1}{4}" \text{ to } 3\frac{1}{8}"$	9 $\frac{5}{8}"$	2 $\frac{1}{2}"$ —6 thd.
16" Spiral	9"	$\frac{1}{4}" \text{ to } 3\frac{1}{8}"$	9 $\frac{5}{8}"$	3 $\frac{3}{4}"$ —4 thd.

Mounting a Chuck on the Dividing Head. Before mounting a chuck on the Dividing Head spindle, remove the front index plate, Fig. 39, page 56. This step is necessary to be sure that the chuck adapter has a square fit on the spindle.

SPIRAL MILLING HEAD (and Gear Cutting Attachment)

The Spiral Milling Head is shown in Figure 62. When the bracket for connecting the driving mechanism (shown at the extreme right) is omitted, the head is known as the "Gear Cutting Attachment". Of course, the type of work-piece milled on the latter attachment is limited to those requiring indexing only, such as spur gears. These heads are suitable for heavy and continuous gear cutting.

The driving mechanism for the Spiral Milling Head is similar to, but not exactly the same as the one for the Dividing Head, Figure 37, page 50. In other words, driving mechanism brackets are not interchangeable between Dividing Heads and Spiral Milling Heads.

All index and lead tables in this booklet apply to the Spiral Milling Head. The index tables only (pages 95-97) apply to the Gear Cutting Attachment.

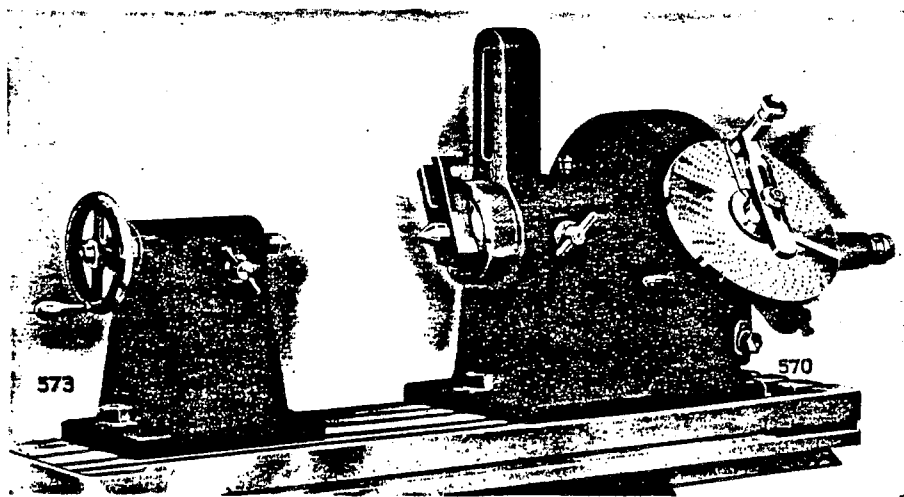

Figure 62
Spiral Milling Head

Specifications for Spiral Milling Heads and Gear Cutting Attachments

Size of Head	Actual Swing	Taper Hole in Spindle	Overall Length of Tailstock	Overall Length of Head
12"	12 $\frac{1}{2}$ "	11 B&S	9 $\frac{3}{8}$ "	15 $\frac{5}{8}$ "
16"	16 $\frac{1}{2}$ "	12 B&S	9 $\frac{3}{8}$ "	16 $\frac{5}{8}$ "

UNIVERSAL SPIRAL MILLING ATTACHMENT

This attachment is used for helical milling in two cases:

1. If the machine is a plain miller, obviously the table can not be swiveled to bring the work piece to the correct helix angle with the cutter. It then becomes necessary to swivel the cutter. This angular setting is obtained by means of the auxiliary Universal Spiral Milling Attachment. (Fig. 63).
2. The table of a universal miller can not be swiveled more than 45° . If the helix angle exceeds this range, the attachment at the right must be used, since it allows the cutter to be swiveled through a complete circle.

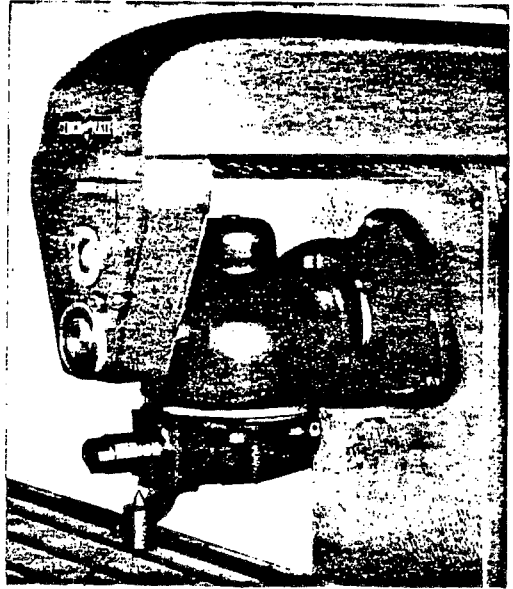

Figure 63
Universal Spiral Milling Attachment

The Universal Spiral Milling Attachment may also be employed for a wide variety of other types of work, such as vertical milling with a shell end mill, rounding out keyways, milling angular surfaces, etc. The attachment spindle runs at the same speed as the machine spindle.

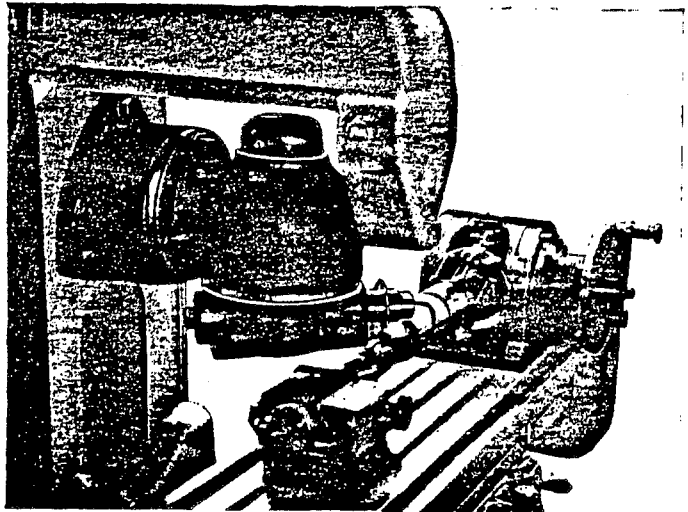

Figure 64
Universal Spiral Milling Attachment and Dividing Head Set Up for Milling the Helical Gear Teeth on a Cam Shaft

HIGH SPEED UNIVERSAL MILLING ATTACHMENTS

Two views of the High Speed Universal Milling Attachment are shown in Figs. 65 and 66. These attachments are for comparatively light work, and are not suitable for face milling operations.

Specifications

Attachment spindle speed:

On Medium Speed Machines,
speed dial reading $\times 3\frac{1}{2}$

On High Speed Machines,
speed dial reading $\times 1\frac{1}{2}$

Swivel range:

Parallel to face of machine
column; 360°

Right angles to face of machine
column; 90°

Taper holes for cutter:

Attachment spindle; No. 40
National Standard

Quill spindle; No. 7 B. & S.

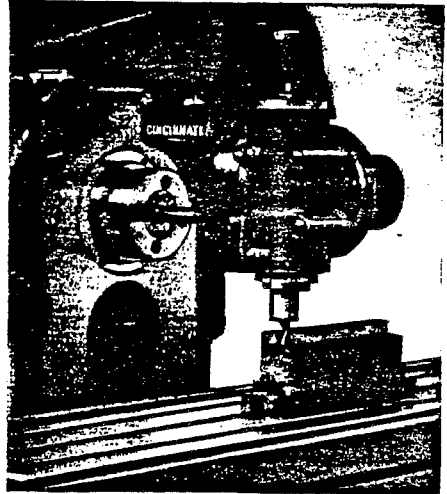

Figure 65
High Speed Universal
Milling Attachment

The standard attachment is shown in Fig. 65, while the attachment equipped with quill device is shown in Fig. 66.

If the attachment is equipped with a quill device, and it is desirable to remove it so that cutters can be inserted in the attachment spindle, proceed in the following manner:

1. Loosen the Allen head set screw in the periphery of hand quill feed knob. Tap the screw lightly to loosen the lock shoe beneath it.
2. In the top end of the knob is an adjusting nut. With a spanner wrench, remove this nut.
3. A slotted adjusting nut is now visible. Remove this nut and its lock washer.

4. Grasp the cutter shank end of the quill and pull it down through the attachment. Replace lock nut and washer, so that they will not be lost. To protect ball bearings, also replace lock nut in hand feed knob.
5. Through the body of the attachment, near the quill nut assembly, you will find a set screw. Remove this set screw.
6. Screw the remainder of the quill device out of the body of the attachment.
7. Now fit the dust cover in place, and lock it with the set screw.
8. Assemble two driving keys in the attachment spindle.
9. Remove the plate on the attachment housing at the rear end of the spindle. It is held in position with four screws.
10. Drive draw-in bolt centering bush into rear end of spindle.
11. Replace cap.

Lubrication. The Universal High Speed Milling Attachment must be lubricated daily while in use. In the grease nipple for the lower spindle bearing, use only medium sponge short fibre grease, sodium soap base. (Same as for stations 15 and 16 on vertical machines—pages 20 and 21.) There are three other grease nipples on the attachment proper, and one oil button in the hand quill feed knob. Periodically apply cup grease and machine oil, respectively.

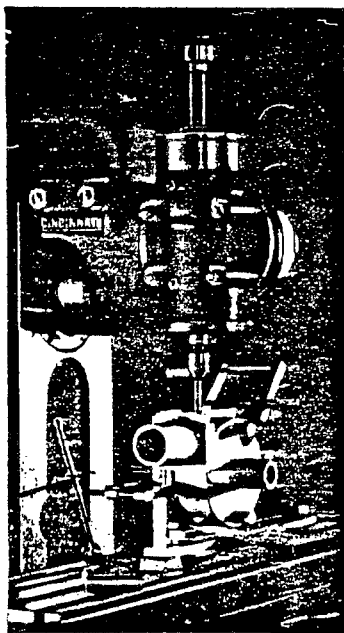

Figure 66
High Speed Universal Milling
Attachment Equipped with
Quill Device

MOTOR DRIVEN UNIVERSAL MILLING OVERARM ATTACHMENT

The Motor Driven Universal Milling Overarm Attachment is illustrated in Fig. 67. It is mounted on a special overarm, and driven by an individual motor, leaving the machine spindle free and usable at any time. Rather heavy cuts, including face milling operations, may be handled with this attachment.

Specifications

Attachment spindle speeds:

100, 130, 180, 245, 310, 435,
580, 740, 1030.

Swivel range:

360° both directions.

Taper hole for cutters:

Attachment spindle, No. 50
National Standard

Quill spindle (extra cost), No.
7 B. & S.

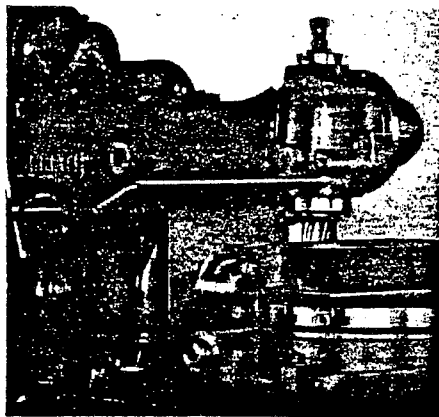

Figure 67
**Motor Driven Universal Milling
Overarm Attachment**

This attachment may also be equipped with a hand feed quill device, similar to the one illustrated in Fig. 66. If the attachment is so equipped, and it becomes desirable to remove the device, proceed in the following manner:

1. Remove the cap on top of the housing. It is held in position by several screws. Lift the cap and quill assembly through the top of the attachment.
2. A bushing and dust ring are furnished as extra parts. Assemble these parts, and replace the cap.
3. From the bottom of the spindle, remove the adapter which is held to it by screws.

The attachment is now ready to be used without the hand feed quill device.

PLAIN AND SWIVEL VISES

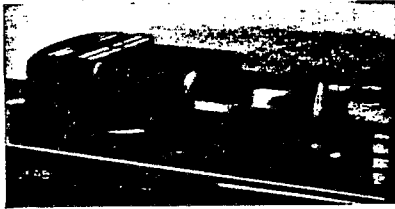

Figure 68
Plain Vise

The plain vise is illustrated in Fig. 68. With the exception of a swivel plate under the body, swivel vises are the same as plain vises. When ordering a vise, give width of T-slot in the table of the machine on which it is to be used.

SPECIFICATIONS FOR PLAIN AND SWIVEL VISES

Size	Depth Jaws	Width Jaws	Jaws Open	Overall Height		Net Weight, Lbs.	
				Plain	Swivel	Plain	Swivel
No. 3	1 5/8"	6 1/8"	4"	4 1/4"	6"	59	79
No. 5	2 1/2"	8 5/8"	7"	5 7/8"	8"	159	204

ALL STEEL VISE



Figure 69
All-Steel Vise

The CINCINNATI All-Steel Vise very effectively and conveniently holds heavy work, easily withstanding the most severe duty imposed on it by the machine. It can be set lengthwise or crosswise on the table. Screw holder "H", Fig. 69, and movable jaw "M" can be quickly set to give approximately the correct opening of the jaws. Plate "A" is hardened to withstand the pressure from the clamping screw. There are four clamping lugs on the solid jaw and one movable clamp "G". Jaw "M" can be swiveled, thus adapting it to the irregularities in rough castings or forgings. The jaws are serrated and hardened, assuring a firm grip on the work piece.

SPECIFICATIONS FOR ALL-STEEL VISE

Size.	Distance from Table to Top of Vise Jaws	Net Weight	Shipping Weight	Code Word
10" x 10" x 2"	4"	80 lbs.	110 lbs.	BYVIS

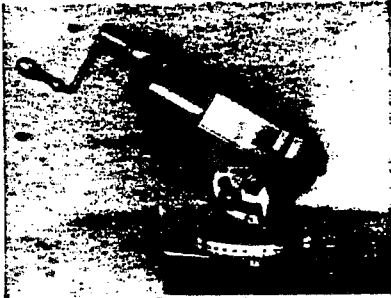

Figure 70
Toolmaker's Universal Vise

TOOL MAKER'S UNIVERSAL VISE

For general tool room work. Can be swiveled in vertical plane up to and including 90 degrees—360 degrees in a horizontal plane. Maximum opening $3\frac{1}{2}$ " ; depth of jaws $1\frac{5}{8}$ " ; width of jaws $6\frac{1}{8}$ " ; net weight 75 pounds.

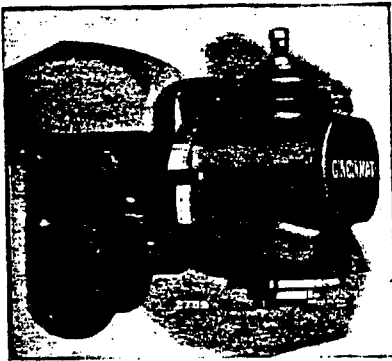

Figure 71
Heavy Vertical Milling Attachment

HEAVY VERTICAL ATTACHMENT

Ideal for face milling where there is not enough work to keep a Vertical Milling Machine busy. Spindle speeds same as machine. Spindle nose same as machine spindle nose. Swivel range 90° total (45° either way from the vertical). Lubricate with good grade of cup grease.

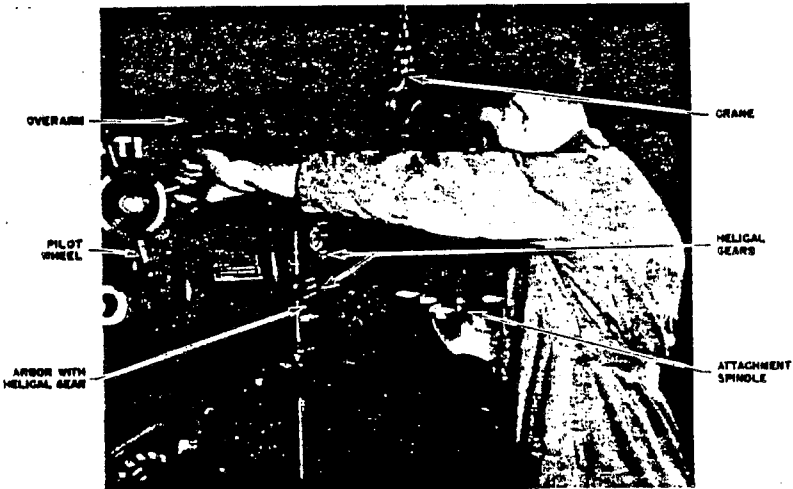

Figure 72
Mounting the Heavy Vertical Milling Attachment on the Machine.

The attachment is clamped to the end of the overarm to facilitate sliding it into mesh with the helical driving gear, using the pilot wheel. Overarm clamps are loose. To mesh gears, turn attachment spindle with one hand.

ENCLOSED DRIVING MECHANISM

The standard Enclosed Driving Mechanism, Fig. 73, may be used on Plain and Vertical Machines. If it is purchased for machines already in use, the table travel will be reduced by about $\frac{3}{4}$ " when the mechanism is set up. To avoid a possible collision of the Driving Mechanism housing with the handle of the lubrication pump, the stop dog must be set as indicated below.

Setting Up the Driving Mechanism the First Time. When a new Driving Mechanism is set up on a used Plain or Vertical Machine the first time,

run the table by hand to its extreme left position after the gear housing is in place. Then set the trip dog to trip the feed just before the housing contacts the oil pump handle (the housing of a universal machine). Stamp an arrow on the table to the right of the dog. Thereafter, when setting up a job requiring the Driving Mechanism, *set the stop dog to the left of the arrow*. An instrument plate containing this caution is supplied with the Driving Mechanism.

This procedure must also be followed the first time a new Circular Milling Attachment Driving Mechanism is set up on a used machine.

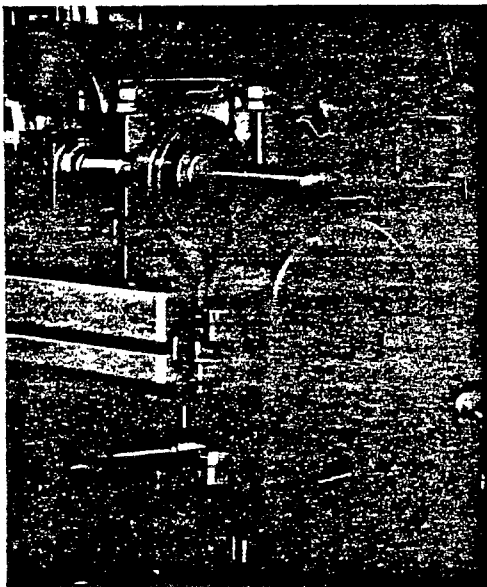

Figure 73
Enclosed Driving Mechanism

SHORT AND LONG LEAD ATTACHMENT

May be obtained at extra cost for Dial Type Universal only. Complimentary parts must be built into the machine at the factory. Has a lead range of .010" to 1000", with no more than the usual number of change gears. Complete instructions are contained in a separate booklet "Long and Short Lead Attachment for CINCINNATI Dial Type Milling Machines", a copy of which accompanies each machine equipped with this attachment.

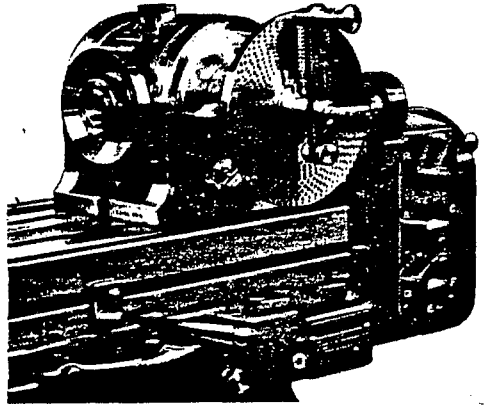

Figure 74
Long and Short Lead Attachment for
Dial Type Milling Machines

MOTOR DRIVEN COOLANT PUMP

An outline drawing of the motor driven coolant pump for CINCINNATI Dial Type Milling Machines is illustrated here. It may easily be installed on the machine (Model ER machines only). Because of its independent control, this type of pump is sometimes desirable when it is necessary to use coolant to wash chips from the fixture or table while the machine is stationary.

The pump is a centrifugal type, mounted on the pad at the side of the base, and connected directly to the coolant reservoir. It is driven by a $\frac{1}{4}$ h. p. motor. Included with the pump are the motor, manual starter, screws for attaching the pump bracket to the machine base, pipe fittings and pipe.

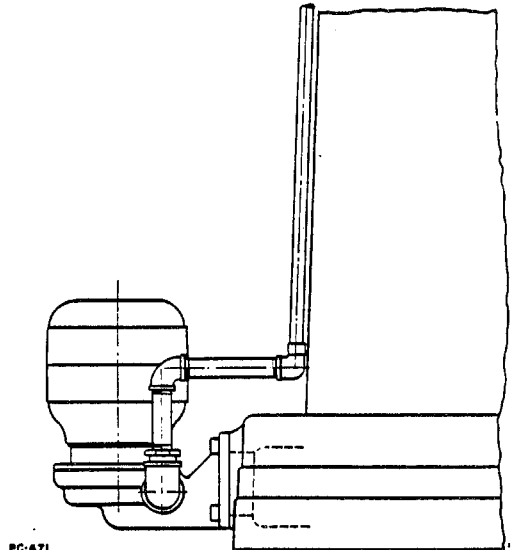

Figure 75
Motor Driven Coolant Pump

RACK MILLING ATTACHMENT

In addition to cutting rack teeth, narrow slotting or side milling cutters may be mounted on the Rack Milling Attachment spindle for milling operations which can be more conveniently handled by using the machine cross feed. A vise designed especially for long rectangular work is included with the attachment.

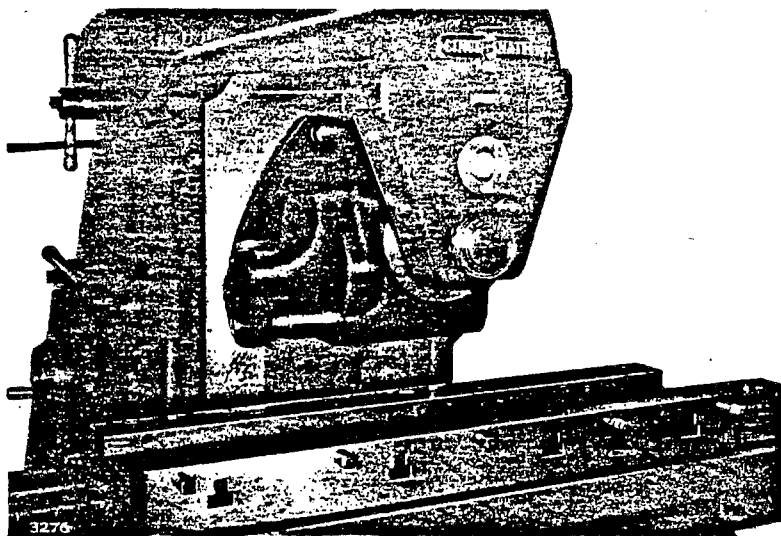

Figure 76
Rack Milling Attachment and Vise Mounted on Machine

SPECIFICATIONS

Size of attachment (diameter of cutter spindle)	1 1/4"
Distance, face of column to center-line of attachment spindle	10 1/2"
Distance, center of machine spindle to center of attachment spindle	3 1/4"
Distance, center of spindle to bottom of attachment	1 7/32"
Maximum diameter of cutters that can be used	4 3/4"
Attachment spindle speed	Same as Machine Spindle Speed
Overall length of cutters that can be used	1 3/4"
Net weight, lbs., about	420
Code Name	RAHIP

RACK INDEXING ATTACHMENT

This attachment, used chiefly in conjunction with the Rack Milling Attachment, is connected to the feed screw at the end of the machine table. It consists of an indexing and locking plate with change gears. Different combinations of gears permit the machine table to be accurately moved in increments, corresponding to the pitch of the rack, by making either a half turn or one complete turn of the plate. For those combinations requiring one complete turn, provision is made to close one of the slots, thus guarding against error.

LIST OF CHANGE GEARS: 28, 35, 42, 44, 49, 56, 63, 70, 77, 84, 88, 91, 98
 Furnished with Rack Indexing Attachment and 105 teeth.

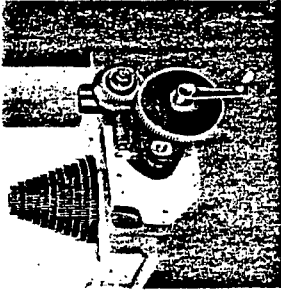

Figure 77
 Rack Indexing Attachment with Change Gears.

TABLE FOR CUTTING RACKS

	4	5	6	7	8	9	10	11	12	13	14	15	16	18	20	22	24	26	28	30	32	
Diametral Pitch																						
Gear on Index Plate	88	88	88	88	88	88	88	88	88	88	88	88	44	88	88	88	88	88	88	88	88	44
Gear on Crankshaft	28	35	42	49	56	63	70	77	84	91	98	105	56	63	70	77	84	91	98	105	56	
Turns of Index Plate	1	1	1	1	1	1	1	1	1	1	1	1	1	1/2	1/2	1/2	1/2	1/2	1/2	1/2	1/2	1/2
Circular Pitch																						
Gear on Index Plate	84	77	70	63	56	56	98	98	56	84	56	70	70	56	84	56	42	56	56	56	28	28
Gear on Crank Shaft	28	28	28	28	28	28	28	56	35	56	42	56	49	42	70	56	84	98	56	56	56	
Turns of Index Plate	1	1	1	1	1	1	1	1	1	1	1	1	1	1	1/2	1	1	1	1	1	1	1/2

CIRCULAR MILLING ATTACHMENTS

Figure 78
20" Circular
Milling
Attachment
Arranged
for Power
Feed

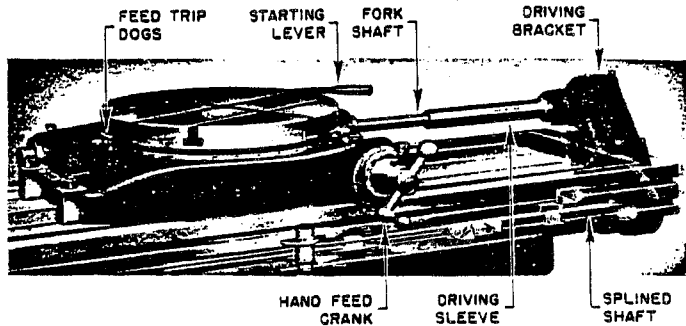

Circular Milling Attachments are built in three sizes, 16", 20", and 24" diameter tables. The 24" size is not recommended for use on Dial Type Milling Machines. The attachment shown in the illustration, Fig. 78, is a 20" size, equipped with power feed. Hand feed attachments are essentially the same except that the driving bracket at the right-hand end of the milling machine table is not supplied.

To set up the Circular Milling Attachment with power feed mechanism, proceed in the following manner. Caution: Also see instructions, "Setting Up Driving Mechanisms for the First Time", page 80.

1. Clean the milling machine table and the bottom of the circular milling attachment.
2. Mount the attachment in the center slot of the table about midway between the ends.
3. Remove the cone-shaped cover at the right-hand end of the table.
4. Remove the hexagon head screw from the end of the spline shaft bearing in the power driving bracket. (Also remove the spline shaft if it has been left in the driving bracket from previous use.)
5. Assemble the driving bracket to the right-hand end of the table with the screws provided, and at the same time slip the driving sleeve from the bracket over the fork shaft from the attachment (or vice-versa if the shaft and sleeve are reversed).
6. Insert the splined shaft in its bearing and push it through until the shoulder rests against the end of the bearing. The other end of the shaft is then engaged in the driving gear. Try by hand to see that it turns without binding.
7. Replace the hexagon head screw in the end of the spline shaft bearing to keep the spline shaft in position.
8. The attachment is now ready to use, either with hand feed or power feed rotary motion. For conventional circular milling, the machine feed levers must be in neutral position (see page 25) and the machine table should be locked in position with the table clamping screws provided for this purpose. (See page 31). For milling scrolls or cams, disregard these two requirements.

Starting and stopping the attachment should always be performed by means of the lever at the rear of the attachment housing. This is labeled "Starting Lever".

To obtain *power rapid traverse* to the circular table, engage the conventional machine rapid traverse lever and then engage the attachment starting lever.

The actual feed rate obtained with the circular milling attachment depends upon two factors, one, diameter of work and two, table feed setting. For example, if the machine feed dial indicates $3\frac{5}{8}$ " per minute, you probably will not be obtaining this feed rate on the work unless the diameter happens to be exactly right.

The tables on pages 88 and 89 list the actual feeds obtained, corresponding to the indicated feed and the diameter of the work to be milled. The tables should be used in this manner—Suppose you have a 20" attachment on the machine with an 8" diameter work piece, and you desire to use a feed of about $4\frac{1}{2}$ " per minute. Under 8" diameter follow down the 20" column until you come to 4.7 and then follow to the left and you will see that you should set the table feed for $3\frac{7}{8}$ " per minute.

Adjustment for the 20" and 24" Attachment. Cincinnati Circular Milling Attachments are provided with means of adjustment for wear between the worm and the worm-wheel.

If this adjustment is necessary on the 20" and 24" sizes, proceed as follows:

1. Remove the hand crank and micrometer dial.
2. Take up the end play of the worm by tightening the adjusting nut. (The worm of the 20" and 24" attachments is provided with ball thrust bearings for absorbing the end thrust when making heavy cuts with power feed.)
3. Replace the micrometer dial and hand crank.
4. Loosen the two hex head screws "A-A" from the bottom of the housing. (Fig. 79)
5. Turn the eccentric bush "B" until there is no play between the worm and worm-wheel. (The sleeve "C" and the worm-wheel are bolted to the circular table and move as a unit in a straight line when the eccentric bush "B" is turned.)
6. Retighten screws "A-A".

Do not make the adjustment so tight as to prohibit free movement of the circular table with the hand crank.

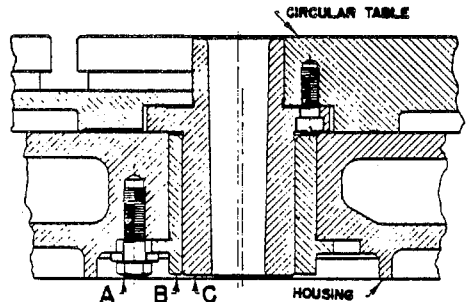

Figure 79
Section Through Eccentric
Adjusting Bush

Adjustment for 16" Attachment. To adjust for wear between the worm and worm-wheel of the 16" attachment proceed as follows:

1. Loosen screw "B" (Fig. 80).
2. Move lever "A" to the left beyond the upper pin hole, fully engaging the worm with the worm-wheel.
3. Tighten screw "B".
4. Loosen screw "C" and turn lever "A" to the right until the pin falls into the upper hole.
5. Retighten screw "C".

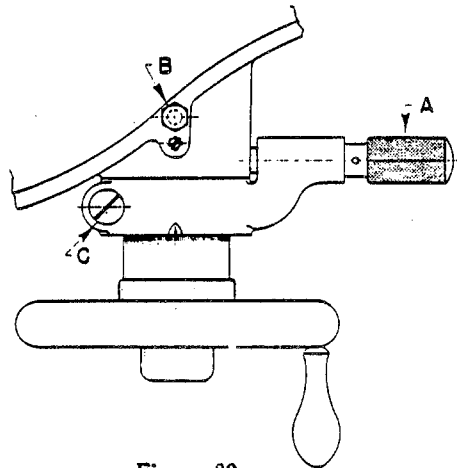

Figure 80
Worm Adjustment for
16" Attachment

Circular gibs are provided to take up the wear between the circular table and housing. To make this adjustment proceed as follows:

1. Remove the four set screws "A" from the bottom of the housing. (Fig. 81.)
2. Tighten each gib adjusting screw "B" the same amount until there is no play in the table. Try table rotation by hand after each screw adjustment.
3. Replace set screws "A". Try table rotation by hand. Must rotate smoothly.

The two $\frac{1}{2}$ " hexagon nuts located between the four set screws are for clamping the table in position.

The driving worm of the 16" attachment may be entirely disengaged from the worm-wheel by moving lever "A" (Fig. 80) to the right until the pin falls into the lower pin hole. The table is then free to revolve independently of the worm.

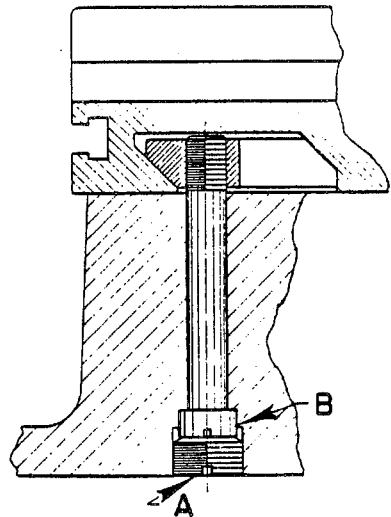

Figure 81
Gib Adjustment for
16" Attachment

CAM MILLING ATTACHMENT

The Cam Milling Attachment is designed for hand feed milling of face cams up to 16" diameter and cylindrical cams up to 8" diameter. Larger diameter cylindrical cams can be cut by using a raising block. Figure 81A shows the attachment in position for milling cylindrical cams. For milling face cams it is only necessary to reset the attachment spindle housing at right angles to the table T-slots.

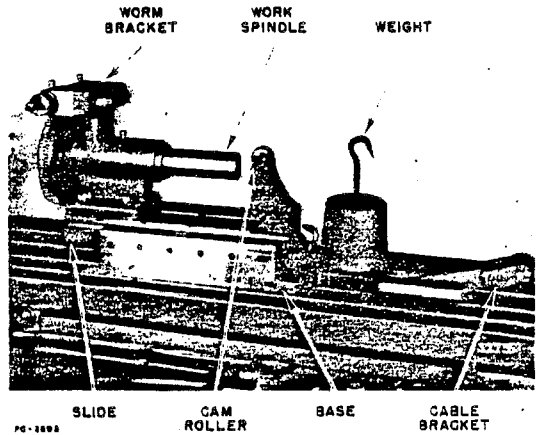

Figure 81A
Cam Milling Attachment

The work spindle supplied is 2" in diameter and 6" long, a plain cylindrical shape. Since cams are more or less specialized items, it will be necessary to make the work holding unit to suit the job. One way to accomplish this is to remove the work spindle and turn it down to suit the inside diameter of the work and master cam. While disassembled, it can be keywayed, and drilled and tapped in the end for a clamping screw. Another method would be to remove the work spindle, cut off the projecting end, and bore out the remainder for a No. 10 or 11 B. & S. taper. When this method is employed, the spindle should be drilled for a $\frac{1}{2}$ " or $\frac{5}{8}$ " draw-in bolt. With the work spindle arranged in this manner, it is a simple matter to select proper arbors from your tool crib.

Note.—Always remove the worm bracket, at the top of the spindle housing, to prevent damage to the worm when removing the work spindle.

To set up this attachment, mount it centrally on the machine table and clamp the base in the center tee-slot. Mount the cable bracket on the right-hand end of the table. After mounting the master cam and the work on the work spindle, attach the cable to the hook in the slide, pass the cable over the cable bracket and attach the weight to the other end. The weight acts to keep the master cam in engagement with the cam roller.

Since the slide is free to move, its longitudinal movement will be controlled by the action of the master cam against the cam roller, as the work spindle is rotated by means of the worm and worm wheel.

FEEDS OBTAINED ON CIRCULAR MILLING ATTACHMENT
CORRESPONDING TO INDICATED FEED AND DIAMETER OF WORK

Dia. Work → Size at attach. →	1'		2'		3'		4'		5'		6'		7'		8'		9'	
	16"	20" and 24"	16"	20" and 24"	16"	20" and 24"	16"	20" and 24"	16"	20" and 24"	16"	20" and 24"	16"	20" and 24"	16"	20" and 24"	16"	20" and 24"
1/2	.084	.168	.170	.252	.284	.420	.340	.504	.397	.588	.454	.672	.511	.756	.454	.672	.511	.756
3/8	.105	.211	.213	.315	.355	.526	.426	.631	.497	.786	.567	.841	.639	.946	.567	.841	.639	.946
1/2	.085	.170	.256	.378	.426	.631	.511	.757	.596	.883	.681	1.01	.766	.946	.681	1.01	.766	.946
3/4	.113	.226	.336	.504	.568	.840	.681	1.01	.795	1.18	.909	1.34	1.51	1.51	.909	1.34	1.51	1.51
1 1/4	.142	.284	.426	.630	.710	1.05	1.05	1.26	1.47	1.99	1.26	1.68	1.89	1.89	1.26	1.68	1.89	1.89
1 3/8	.156	.312	.463	.694	.825	1.16	1.16	1.39	1.62	2.16	1.39	1.81	2.08	2.08	1.39	1.81	2.08	2.08
1 1/2	.170	.340	.511	.755	.852	1.26	1.26	1.51	1.76	2.38	1.51	2.02	2.27	2.27	1.51	2.02	2.27	2.27
1 3/4	.199	.398	.596	.882	.995	1.47	1.47	1.76	2.06	2.88	1.76	2.35	2.64	2.64	1.76	2.35	2.64	2.64
2	.227	.454	.681	1.01	1.13	1.68	1.68	2.02	2.35	3.24	2.02	2.77	3.02	3.02	2.02	2.77	3.02	3.02
2 1/8	.241	.482	.724	1.07	1.21	1.78	1.78	2.14	2.50	3.44	2.14	2.88	3.16	3.16	2.14	2.88	3.16	3.16
2 1/4	.257	.514	.771	1.13	1.28	1.85	1.85	2.23	2.62	3.58	2.23	2.99	3.28	3.28	2.23	2.99	3.28	3.28
2 3/4	.312	.625	.938	1.38	1.56	2.31	2.31	2.77	3.32	4.44	2.77	3.66	4.00	4.00	2.77	3.66	4.00	4.00
3 1/2	.398	.795	1.19	1.76	1.99	2.94	2.94	3.53	4.32	5.76	3.53	4.70	5.29	5.29	3.53	4.70	5.29	5.29
3 3/8	.412	.824	1.23	1.83	2.05	3.04	3.04	3.66	4.44	5.92	3.66	4.87	5.49	5.49	3.66	4.87	5.49	5.49
4 1/4	.483	.965	1.44	2.14	2.41	3.57	3.57	4.28	5.00	6.56	4.28	5.62	6.29	6.29	4.28	5.62	6.29	6.29
4 3/8	.525	.777	1.05	1.55	1.77	2.62	2.62	3.15	3.88	5.00	3.15	4.00	4.44	4.44	3.15	4.00	4.44	4.44
5 1/2	.624	.924	1.24	1.85	2.11	3.11	3.11	3.74	4.62	5.92	3.74	4.94	5.54	5.54	3.74	4.94	5.54	5.54
5 3/4	.653	.966	1.31	1.93	2.20	3.26	3.26	3.92	4.83	6.16	3.92	5.16	5.79	5.79	3.92	5.16	5.79	5.79
7 1/4	.824	1.22	1.64	2.44	2.89	4.12	4.12	4.94	6.10	7.76	4.94	6.32	7.00	7.00	4.94	6.32	7.00	7.00
7 3/8	.866	1.28	1.73	2.56	3.04	4.33	4.33	5.20	6.40	8.00	5.20	6.64	7.36	7.36	5.20	6.64	7.36	7.36
9 1/4	1.05	1.55	2.24	3.10	3.62	5.25	5.25	6.30	7.77	9.60	6.30	8.00	8.96	8.96	6.30	8.00	8.96	8.96
9 3/8	1.12	1.66	2.24	3.32	3.96	5.60	5.60	6.72	8.30	10.08	6.72	8.64	9.60	9.60	6.72	8.64	9.60	9.60
11 1/2	1.30	1.93	2.61	3.86	4.52	6.54	6.54	7.84	9.67	12.00	7.84	10.00	11.04	11.04	7.84	10.00	11.04	11.04
12 3/8	1.40	2.08	2.81	4.16	4.91	7.03	7.03	8.43	10.4	12.96	8.43	10.56	11.52	11.52	8.43	10.56	11.52	11.52
15 1/4	1.73	2.56	3.46	5.12	6.02	8.65	8.65	10.4	12.8	16.00	10.4	12.96	14.4	14.4	10.4	12.96	14.4	14.4
15 3/8	1.74	2.58	3.49	5.16	6.06	8.74	8.74	10.3	12.9	16.32	10.3	12.96	14.56	14.56	10.3	12.96	14.56	14.56
19 1/4	2.24	3.32	4.42	6.64	7.74	11.0	11.0	13.2	16.6	20.16	13.2	16.64	19.2	19.2	13.2	16.64	19.2	19.2
20	2.27	3.36	4.54	6.72	7.84	11.3	11.3	13.6	16.8	20.4	13.6	16.8	19.44	19.44	13.6	16.8	19.44	19.44
24 1/4	2.81	4.16	5.63	8.32	10.4	14.0	14.0	16.6	20.8	25.92	16.6	20.8	24.48	24.48	16.6	20.8	24.48	24.48
30 1/4	3.49	5.16	7.00	10.3	12.4	17.4	17.4	20.6	25.8	31.68	20.6	25.8	30.24	30.24	20.6	25.8	30.24	30.24
30 3/4	3.49	5.16	7.00	10.3	12.4	17.4	17.4	20.6	25.8	31.68	20.6	25.8	30.24	30.24	20.6	25.8	30.24	30.24
40	4.54	6.72	9.09	13.4	15.6	20.1	20.1	26.8	33.6	44.16	26.8	33.6	40.4	40.4	26.8	33.6	40.4	40.4

INDICATED TABLE FEEDS

FEEDS OBTAINED ON CIRCULAR MILLING ATTACHMENT
CORRESPONDING TO INDICATED FEED AND DIAMETER OF WORK

Dia. Work → Size Attach →	10'		11'		12'		13'		14'		15'		16'		17'		18'		19'		20'	
	16"	20' and 24"	16"	20' and 24"	16"	20' and 24"	16"	20' and 24"	16"	20' and 24"	16"	20' and 24"	16"	20' and 24"	16"	20' and 24"	16"	20' and 24"	16"	20' and 24"	16"	20' and 24"
1/2	.568	8.40	.625	.924	.681	1.01	.738	1.09	.795	1.17	.853	1.26	.909	1.34	1.43	1.51	1.59	1.68	1.77	1.86	1.95	2.04
5/8	.710	1.05	.781	1.16	.852	1.26	.924	1.36	.994	1.47	1.06	1.58	1.13	1.68	1.79	1.89	1.99	2.11	2.22	2.33	2.44	2.55
3/4	.852	1.26	.937	1.39	1.02	1.51	1.11	1.64	1.10	1.77	1.28	1.89	1.36	2.02	2.14	2.27	2.4	2.52	2.63	2.74	2.85	2.96
1	1.14	1.68	1.25	1.85	1.36	2.02	1.47	2.18	1.59	2.35	1.70	2.52	1.81	2.68	2.86	3.02	3.19	3.36	3.47	3.58	3.69	3.80
1 1/4	1.42	2.10	1.56	2.31	1.70	2.52	1.84	2.73	1.98	2.94	2.13	3.14	2.27	3.36	3.58	3.78	4.00	4.21	4.32	4.43	4.54	4.65
1 1/2	1.56	2.31	1.72	2.54	1.87	2.77	2.32	3.00	2.18	3.24	2.34	3.46	2.50	3.70	3.927	4.16	4.39	4.62	4.73	4.84	4.95	5.06
1 3/4	1.70	2.52	1.87	2.77	2.04	3.02	2.21	3.28	2.38	3.53	2.55	3.78	2.72	4.04	4.28	4.54	4.79	5.04	5.15	5.26	5.37	5.48
2	1.99	2.94	2.18	3.24	2.38	3.53	2.58	3.82	2.78	4.12	2.98	4.41	3.18	4.70	5.00	5.29	5.59	5.88	6.00	6.11	6.22	6.33
2 1/4	2.27	3.36	2.50	3.70	2.72	4.04	2.95	4.37	3.18	4.71	3.40	5.05	3.63	5.38	5.71	6.05	6.40	6.73	6.85	6.96	7.07	7.18
2 1/2	2.41	3.57	2.65	3.92	2.89	4.28	3.14	4.64	3.38	5.00	3.62	5.35	3.86	5.71	6.07	6.42	6.78	7.14	7.26	7.37	7.48	7.59
2 3/4	3.12	4.62	3.44	5.08	3.75	5.54	4.06	6.00	4.37	6.47	4.69	6.94	5.00	7.40	7.86	8.32	8.78	9.24	9.36	9.47	9.58	9.69
3 1/2	3.98	5.88	4.37	6.47	4.76	7.06	5.16	7.65	5.56	8.24	5.96	8.83	6.36	9.41	10.0	10.6	11.1	11.7	11.8	11.9	12.0	12.1
3 3/4	4.12	6.09	4.52	6.70	4.94	7.32	5.53	7.92	5.76	8.54	6.17	9.14	6.59	9.74	10.3	10.9	11.5	12.1	12.2	12.3	12.4	12.5
4 1/4	4.83	7.14	5.30	7.85	5.79	8.56	6.26	9.28	6.75	10.0	7.24	10.7	7.71	11.4	12.1	12.8	13.5	14.3	14.4	14.5	14.6	14.7
4 1/2	5.25	7.77	5.77	8.55	6.30	9.34	6.82	10.1	7.35	10.9	7.86	11.6	8.40	12.4	13.2	13.9	14.7	15.5	15.6	15.7	15.8	15.9
5 1/4	6.25	9.24	6.86	10.1	7.49	11.1	8.11	12.0	8.74	12.9	9.36	13.8	10.0	14.8	15.7	16.6	17.5	18.4	18.5	18.6	18.7	18.8
5 1/2	6.53	9.66	7.19	10.6	8.50	12.5	9.15	13.5	9.15	13.5	9.80	14.5	10.4	15.5	16.4	17.3	18.3	19.3	19.4	19.5	19.6	19.7
5 3/4	8.24	12.2	9.06	13.4	10.7	15.8	11.5	17.5	11.5	17.5	12.3	18.3	13.2	19.5	20.7	21.9	23.2	24.4	24.5	24.6	24.7	24.8
7 1/4	8.66	12.8	9.53	14.1	10.4	15.3	11.2	16.6	12.1	17.9	13.0	19.2	13.8	20.5	21.8	23.0	24.3	25.6	25.7	25.8	25.9	26.0
9 1/4	10.5	15.5	11.5	17.1	12.6	18.6	13.6	20.2	14.7	21.7	15.7	23.3	16.8	24.8	26.4	27.9	29.5	31.0	31.1	31.2	31.3	31.4
9 1/2	11.2	16.6	12.3	18.3	13.4	19.9	14.5	21.6	15.7	23.2	16.8	24.9	17.9	26.6	28.2	29.8	31.5	33.2	33.3	33.4	33.5	33.6
11 1/2	13.0	19.3	14.6	21.2	15.6	23.2	16.9	25.1	18.3	27.0	19.6	29.0	20.8	30.9	32.8	34.8	36.7	38.6	38.7	38.8	38.9	39.0
12 1/2	14.0	20.8	15.4	22.9	16.8	24.9	18.2	27.0	19.7	29.1	21.1	31.2	22.4	33.2	35.3	37.4	39.5	41.6	41.7	41.8	41.9	42.0
15 1/4	17.3	25.6	19.0	28.18	20.8	30.7	22.5	33.3	24.2	35.8	25.9	38.4	27.7	41.0	43.6	46.2	48.7	51.2	51.3	51.4	51.5	51.6
15 1/2	17.4	25.8	19.2	28.4	21.0	30.9	22.7	33.5	24.4	36.1	26.2	38.7	27.9	41.3	43.9	46.4	49.0	51.6	51.7	51.8	51.9	52.0
16 1/4	22.4	33.2	24.3	36.4	26.5	39.8	28.7	43.1	30.9	46.4	33.6	49.7	35.3	53.0	56.4	59.6	63.0	66.4	66.5	66.6	66.7	66.8
20	22.7	33.6	25.0	37.0	27.2	40.3	29.5	43.6	31.8	47.0	34.0	50.4	36.3	53.7	57.1	60.5	63.9	67.2	67.3	67.4	67.5	67.6
24 1/4	28.1	41.6	30.9	45.8	33.7	49.9	36.5	51.1	39.3	58.3	42.2	62.4	45.0	66.6	70.7	74.9	79.0	83.2	83.3	83.4	83.5	83.6
30 1/4	34.9	51.6	38.4	56.8	41.9	62.0	45.5	67.1	48.9	72.4	52.4	77.5	55.9	82.6	87.8	93.0	98.2	103.2	103.3	103.4	103.5	103.6
40	45.4	67.2	50.0	73.9	54.5	80.6	59.0	87.5	63.6	94.1	68.2	100.9	72.7	107.5	114.2	120.1	127.9	134.4	134.5	134.6	134.7	134.8

METHOD OF CALCULATING MACHINING TIME

The actual cutting time for milling any piece of work may be calculated from the following formula.

$$T = \frac{L + A + O}{F}$$

- T = Actual Milling Time in Minutes.
 L = Length of Cut in Inches.
 A = Approach of Cutter in Inches.
 O = Over-travel of Cutter in Inches.
 F = Feed in Inches per Minute.

The approach of the cutter is the distance the table must move the work into the cutter before full cutting depth or width is attained. (Dimension "A" in Figs. 82, 83 and 84.)

The over-travel of the cutter is the distance the table must travel in power feed minus the total length of the cut. It is a safety factor to allow for variations in the length of the work piece and in clamping.

The feed is the most important factor, but there are such wide variations in feed depending upon the cutter, material, and the method of holding the work that the judgment of the set up man or operator must be relied upon to determine the correct feed. A discussion of feeds and speeds is contained in our booklet "Milling Machine Practice" a copy of which may be obtained free of charge.

Example: Suppose a cast-iron bracket is to be milled on one side with an end or face mill, under the following conditions of feed, length of cut, etc. Calculate the actual cutting time.

Length of Cut	8"
Width of Cut	4"
Diameter of Cutter	6"
Over-travel	assume $\frac{1}{4}$ "
Feed	11" per minute

Then $L = 8"$
 $A = .77"$ (See table entitled "Approach of Cutter for End Mills and Face Mills", page 92.)
 $O = \frac{1}{4}"$
 $F = 11"$

$$\text{And } T = \frac{8 + .77 + .25}{11} = .82 \text{ minutes.}$$

Total time, floor to floor = .82 + Handling Time + Time to Clear Work of Cutters.

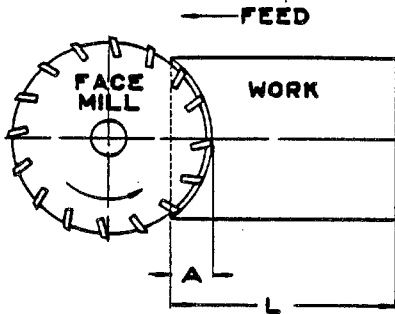

Figure 82

Approach of Cutter for Face and End Mills, with Center of Cutter Approximately in Line with Center of Work.

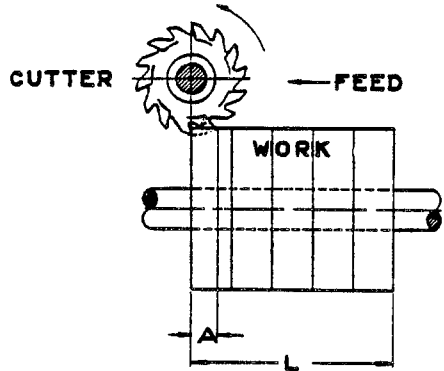

Figure 83

Approach of Cutter for Slab Milling, Keywaying, Gear Cutting, Sawing, etc.

Example: Suppose a gang of five gear blanks are to be milled between the centers of a Dividing Head, under the following conditions of feed, depth of cut, etc. Calculate the actual cutting time.

Width of Gear Face.....	1"
Whole Depth of Tooth.....	.270"
Diameter of Cutter.....	2 3/4"
Over-travel.....	assume 1/8"
Feed.....	8 1/8" per minute

Then $L = 5"$ (Five gears, each 1" wide.)
 $A = .79"$ (See table entitled "Approach of Cutter for Spiral Mills, Keyway Cutters, Saws, etc.", page 93.)
 $O = 1/8"$
 $F = 8 1/8"$

$$\text{And } T \text{ per tooth} = \frac{5 + .79 + .125}{8.125} = .73 \text{ minutes}$$

Total time floor to floor:

$$= \frac{(.73 \times \text{No. of teeth}) + (\text{indexing time for one tooth} \times \text{No. of teeth} - 1)}{5}$$

$$+ \frac{\text{handling time} + \text{time to clear work of cutters.}}{5}$$

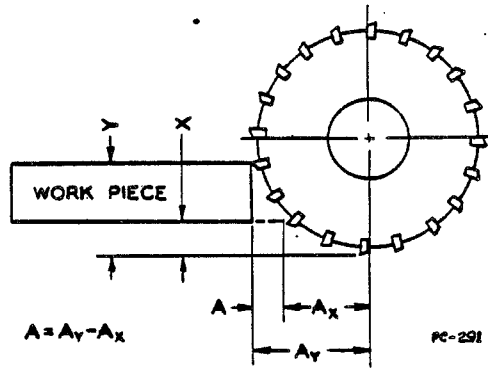

Figure 84
 Approach of Cutter for Face and End Mills.
 with Center of Cutter Offset from Center of Work.

Example: If we have a part which requires a cut with an end mill or a face mill, and the center-line of the work does not coincide with the center of the cutter, Figure 84, the approach cannot be read directly from the table. Assuming an extreme condition, suppose we have an 8" diameter face mill taking a 2½" width of cut, and that one edge of the work is 1½" from the periphery of the cutter (dimension "X" in Figure 84), while the opposite edge is 4" from the periphery (dimension "Y" = 1½" + 2½"). Then the approach of the cutter is the difference between the approach for a 4" depth of cut and a 1½" depth of cut. In the table entitled "Approach of Cutter for Spiral Mills, Keyway Cutters, Saws, etc.", the approach for an 8" cutter at a 4" depth is 4", while at a 1½" depth, it is 3.12". The difference between 4" and 3.12" equals .88", the correct approach in this particular case.

Approach of Cutter for End Mills and Face Mills
 (Center of Cutter Approximately in Line with Center of Work)

Dia. of Mill	WIDTH OF CUT											
	1"	2"	3"	4"	5"	6"	7"	8"	9"	10"	11"	12"
1	.5											
1½	.192											
2	.135											
2½	.105	.5										
3	.09	.37	.5									
4	.07	.27	.68	.2								
5	.05	.24	.5	.1	2.5							
6	.04	.18	.4	.77	1.34	3.						
7½	.04	.14	.32	.59	.96	1.51	2.63					
8	.033	.13	.29	.54	.88	1.36	2.07	.4				
10	.025	.10	.23	.43	.56	1.00	1.43	.2	2.82	.5		
12	.020	.08	.19	.35	.54	.81	1.13	1.53	2.04	2.69	3.6	.6

How to Read the Table: Follow down the column headed "Dia. of Mill" until you come to the diameter of cutter which you are using. Follow across to the right until you come to the column under the width of cut which the cutter is taking. The figure given is the approach of the cutter

Example: 10" diameter face mill; 8" width of cut; approach of cutter is 2".

Approach of Cutter for Spiral Mills, Keyway Cutters, Saws, Etc.

Dia. of Mill	DEPTH OF CUT											
	1/8"	1/8"	3/8"	1/4"	3/8"	1/2"	3/4"	1"	1 1/2"	2"	3"	
1 1/4	.272	.37	.44	.50	.57	.612						
1 1/2	.299	.41	.49	.56	.65	.71	.75					
1 3/4	.32	.45	.54	.61	.72	.79	.87					
2	.35	.48	.58	.66	.78	.87	.97	1.00				
2 1/4	.37	.52	.62	.71	.84	.93	1.06	1.12				
2 1/2	.39	.54	.66	.75	.89	1.00	1.15	1.22				
2 3/4	.41	.57	.69	.79	.94	1.06	1.22	1.32				
3	.43	.60	.73	.83	.99	1.12	1.30	1.41	1.50			
3 1/4	.45	.63	.76	.87	1.04	1.17	1.37	1.50	1.62			
3 1/2	.46	.65	.79	.91	1.08	1.22	1.44	1.58	1.73			
3 3/4	.48	.67	.82	.93	1.13	1.28	1.50	1.66	1.84			
4	.49	.70	.85	.97	1.17	1.32	1.56	1.73	1.94	2.00		
4 1/4	.511	.72	.87	1.00	1.21	1.37	1.62	1.80	2.03	2.12		
4 1/2	.53	.74	.90	1.03	1.24	1.41	1.67	1.87	2.12	2.24		
4 3/4	.54	.76	.92	1.06	1.28	1.46	1.73	1.93	2.21	2.35		
5	.56	.78	.95	1.09	1.32	1.50	1.79	2.00	2.29	2.45		
5 1/2	.58	.82	1.00	1.14	1.39	1.58	1.89	2.12	2.45	2.64		
6	.61	.86	1.04	1.20	1.45	1.66	1.98	2.24	2.60	2.83	3.00	
6 1/2	.634	.89	1.09	1.25	1.51	1.73	2.08	2.35	2.74	3.00	3.24	
7	.658	.93	1.13	1.30	1.58	1.80	2.17	2.45	2.87	3.16	3.46	
7 1/2	.68	.95	1.17	1.35	1.63	1.87	2.25	2.55	3.00	3.32	3.67	
8	.71	.99	1.21	1.39	1.69	1.94	2.33	2.65	3.12	3.46	3.87	4.00
8 1/2	.73	1.03	1.25	1.44	1.74	2.00	2.41	2.74	3.24	3.61	4.06	4.24
9	.75	1.05	1.28	1.48	1.80	2.06	2.49	2.83	3.36	3.74	4.24	4.47
9 1/2	.77	1.08	1.32	1.52	1.85	2.12	2.56	2.92	3.47	3.88	4.42	4.69
10	.79	1.11	1.35	1.56	1.90	2.18	2.63	3.00	3.57	4.00	4.58	4.90
10 1/2	.81	1.14	1.39	1.60	1.95	2.24	2.71	3.08	3.67	4.12	4.75	5.10
11	.83	1.17	1.42	1.64	2.00	2.29	2.77	3.16	3.77	4.24	4.89	5.29
11 1/2	.85	1.19	1.46	1.68	2.04	2.34	2.84	3.24	3.87	4.36	5.04	5.48
12	.86	1.22	1.49	1.72	2.09	2.40	2.91	3.32	3.97	4.47	5.19	5.65

How to Read the Table—Follow down the column headed "Dia. of Mill" until you come to the diameter of cutter which you are using. Follow across to the right until you come to the column under the depth of cut which the cutter is taking. The figure given is the approach of the cutter.

Example: 2 3/4" diameter cutter, 1/4" depth of cut; approach of cutter is .79".

DIVIDING HEAD NOTES

INDEX TABLES (Numerical Divisions)

For Standard Dividing Head Plate (Page 46) and Wide Range Divider (Page 58)
 (See pages 59 and 60 for method of calculating angular spacings and divisions not listed for the Wide Range Divider)

Table of divisions obtainable with the standard Index Plate and the large plate of the Wide Range Divider, used with Dividing Heads, Gear Cutting Attachments, Spiral Milling Heads and Plain Centers.

The plates are drilled on both sides with circles of holes equally spaced. The number of holes in the circles are as follows:

Standard Dividing Head Plate Page 46	}	First Side—24-25-28-30-34-37-38-39-41-42-43
		Second Side—46-47-49-51-53-54-57-58-59-62-66
Large Plate of Wide Range Divider Page 58	}	First Side—24-28-30-34-37-38-39-41-42-43-100
		Second Side—46-47-49-51-53-54-57-58-59-62-66

No. of Divisions	Circle	Turns	Spaces	No. of Divisions	Circle	Turns	Spaces	No. of Divisions	Circle	Spaces	No. of Divisions	Circle	Spaces	No. of Divisions	Circle	Spaces	No. of Divisions	Circle	Spaces
2	Any	20	37	37	1	3	80	24	12	148	37	10	248	62	10	460	46	4
3	24	13	8	38	38	1	2	82	41	20	150	30	8	250	25	4	464	58	5
4	Any	10	39	39	1	1	84	42	20	152	38	10	255	51	8	470	47	4
5	Any	8	40	Any	1	85	34	16	155	62	16	260	39	6	472	59	5
6	24	6	16	41	41	40	86	43	20	158	39	10	264	66	10	480	24	2
7	28	5	20	42	42	40	88	66	30	160	28	7	270	54	8	490	49	4
8	Any	5	43	43	40	90	54	24	164	41	10	272	34	5	496	62	5
9	54	4	24	44	66	60	92	46	20	165	66	16	280	28	4	500	25	2
10	Any	4	45	54	48	94	47	20	168	42	10	290	58	8	510	51	4
11	66	3	42	46	46	40	95	38	16	170	34	8	296	37	5	520	39	3
12	24	3	8	47	47	40	96	24	10	172	43	10	300	30	4	528	66	5
13	30	3	3	48	24	20	98	49	20	176	66	15	304	38	5	530	53	4
14	49	2	42	49	49	40	100	25	10	180	54	12	310	62	8	540	54	4
15	24	2	16	50	25	20	102	51	20	184	46	10	312	39	5	560	28	2
16	24	2	12	51	51	40	104	39	15	185	37	8	320	24	3	570	57	4
17	34	2	12	52	39	30	105	42	18	188	47	10	328	41	5	580	58	4
18	54	2	12	53	53	40	106	53	20	190	38	8	330	66	8	590	59	4
19	38	2	4	54	54	40	108	54	20	192	24	5	336	42	5	600	30	2
20	Any	2	55	66	48	110	66	24	195	39	8	340	34	4	620	62	4
21	42	1	38	56	28	20	112	28	10	196	49	10	344	43	5	680	66	4
22	66	1	54	57	57	40	114	57	20	200	30	6	360	54	6	680	34	2
23	46	1	34	58	58	40	115	46	16	204	51	10	368	46	5	720	54	3
24	24	1	16	59	59	40	116	58	20	205	41	8	370	37	4	740	37	2
25	25	1	15	60	24	16	118	59	20	210	42	8	376	47	5	760	38	2
26	39	1	21	62	62	40	120	24	8	212	53	10	380	38	4	780	39	2
27	54	1	26	64	24	15	124	62	20	215	43	8	390	39	4	820	41	2
28	42	1	18	65	39	24	125	25	8	218	54	10	392	49	5	840	42	2
29	58	1	22	66	66	40	130	39	12	220	66	12	400	30	3	860	43	2
30	24	1	8	68	34	20	132	66	20	224	28	5	408	51	5	880	66	3
31	62	1	18	70	28	16	135	54	16	228	57	10	410	41	4	920	46	2
32	28	1	7	72	54	30	136	34	10	230	46	8	420	42	4	940	47	2
33	66	1	14	74	37	20	140	28	8	232	58	10	424	53	5	960	24	1
34	34	1	6	75	30	16	144	54	15	235	47	8	430	43	4	980	49	2
35	28	1	4	76	38	20	145	58	16	236	59	10	432	54	5	1000	25	1
36	54	1	6	78	39	20				240	24	4	440	66	6			
											245	49	8	456	57	5			

INDEX TABLE (Numerical Divisions) FOR HIGH NUMBER INDEXING ATTACHMENT

indexes all numbers up to and including 200; all even numbers and those divisible by 5 up to and including 400, except 225, 275, 325, 375.
This attachment consists of a set of 3 index plates which are drilled on six sides, A, B, C, D, E and F. Example to index 35 divisions—This division can be made from side F, D, A, or E. The preferred side is F, since this requires the least number of holes. But should either D, A or E be in place, it can be used, thus avoiding the bother of changing plates.

No. of Div.	Side A				Side B				Side C				Side D				Side E				Side F									
	Circle	Turns	Spaces	No. of Div.	Circle	Turns	Spaces	No. of Div.	Circle	Turns	Spaces	No. of Div.	Circle	Turns	Spaces	No. of Div.	Circle	Turns	Spaces	No. of Div.	Circle	Turns	Spaces	No. of Div.	Circle	Turns	Spaces	No. of Div.	Circle	Turns
2	Any	Any	20	19	F	38	2	4	41	C	123	120	70	D	42	24														
3	A	30	13	10	E	133	2	2	42	E	42	40	70	A	91	52														
3	B	36	13	12	A	171	1	18	42	A	147	140	70	F	119	68														
3	E	42	13	14	20	Any	Any	2	43	A	129	120	71	F	71	40														
3	C	43	13	31	21	E	42	1	38	D	44	40	72	B	36	20														
3	F	159	13	53	21	A	147	1	133	A	99	90	72	A	117	65														
4	Any	Any	10	...	22	D	44	1	36	F	143	130	72	C	153	85														
4	Any	Any	8	...	22	A	99	1	81	B	36	32	73	E	73	40														
5	A	30	6	20	22	F	143	1	117	A	99	88	74	B	111	60														
5	B	36	6	24	23	C	46	1	34	C	153	136	75	A	30	16														
5	E	42	6	28	23	A	69	1	51	C	46	40	78	F	38	20														
5	C	93	6	62	23	E	161	1	119	A	69	60	78	E	133	70														
5	F	159	6	106	24	A	30	1	20	E	161	140	78	A	171	90														
7	F	28	5	20	24	B	36	1	24	B	141	120	77	D	77	40														
7	E	42	5	30	24	E	42	1	28	A	30	25	78	A	117	60														
7	D	77	5	55	24	C	93	1	62	B	36	30	79	C	79	40														
7	A	91	5	65	24	F	159	1	106	A	147	120	80	E	26	13														
8	Any	Any	5	...	25	A	30	1	18	A	30	24	80	F	28	14														
8	B	36	4	16	25	E	175	1	105	E	175	140	80	A	30	15														
8	A	99	4	44	26	E	26	1	14	C	153	120	80	D	32	16														
8	C	153	4	68	26	A	91	1	49	E	26	20	80	C	34	17														
10	Any	Any	4	...	26	B	169	1	91	A	91	70	80	B	36	18														
11	D	44	3	28	27	B	81	1	39	F	143	110	80	E	42	21														
11	A	99	3	63	27	A	189	1	91	B	169	130	81	B	91	40														
11	F	143	3	91	28	F	28	1	12	F	159	120	82	C	123	60														
12	A	30	3	10	28	E	42	1	18	B	81	60	83	F	83	40														
12	B	36	3	12	28	D	77	1	33	A	189	140	84	E	42	20														
12	E	42	3	14	28	A	91	1	39	D	44	32	84	A	147	70														
12	C	93	3	31	29	E	87	1	33	F	143	104	85	C	34	16														
12	F	159	3	53	30	A	30	1	10	F	28	20	85	E	119	56														
13	E	26	3	2	30	B	36	1	12	E	42	30	85	F	187	88														
13	A	91	3	7	30	C	42	1	14	D	77	55	86	A	129	60														
13	F	143	3	11	30	E	93	1	31	A	91	65	87	E	87	40														
13	B	169	3	13	30	F	159	1	53	A	171	120	88	D	44	20														
14	F	28	2	24	31	C	93	1	27	E	87	60	88	A	99	45														
14	E	42	2	36	32	F	28	1	7	A	177	120	88	F	143	65														
14	D	77	2	66	32	D	32	1	8	B	30	20	89	D	89	40														
14	A	91	2	78	32	B	36	1	9	A	36	24	90	B	36	16														
15	A	30	2	20	32	A	48	1	12	E	42	28	90	A	99	44														
15	B	36	2	24	33	A	99	1	21	B	159	106	90	C	153	68														
15	E	42	2	28	34	C	34	1	6	F	183	120	91	A	91	40														
15	C	93	2	62	34	E	119	1	21	C	93	60	92	C	46	20														
15	F	159	2	106	34	F	187	1	33	A	189	120	92	A	69	30														
16	E	26	2	13	35	F	28	1	4	D	32	20	92	E	161	70														
16	F	28	2	14	35	D	77	1	11	A	48	30	93	C	93	40														
16	A	30	2	15	35	A	91	1	13	E	26	16	94	B	141	60														
16	D	32	2	16	35	E	119	1	17	A	91	56	95	F	38	16														
16	C	34	2	17	36	B	36	1	4	F	143	88	95	E	133	56														
16	B	36	2	18	36	A	99	1	11	B	169	104	95	A	171	72														
17	C	34	2	12	36	C	153	1	17	A	99	60	96	B	36	15														
17	E	119	2	42	37	B	111	1	9	B	67	40	96	A	48	20														
17	F	153	2	54	38	F	38	1	2	C	134	20	97	B	97	40														
17	C	187	2	66	38	E	133	1	7	E	119	70	98	A	147	60														
18	B	36	2	8	38	A	171	1	9	F	187	110	99	A	99	40														
18	A	99	2	22	39	A	117	1	3	A	69	40	100	A	30	12														
18	C	153	2	34	40	Any	Any	1	...	F	28	16	100	E	175	70														

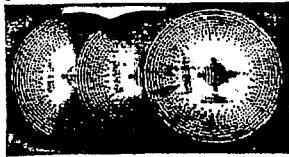

INDEX TABLE—(Concluded)
FOR HIGH NUMBER INDEXING ATTACHMENT

Fig. 85 . . . The High Number Indexing Attachment is used by replacing the standard index plate with the High Number plate which will give you the number of divisions required.

No. of Div.	Slide	Circle	Spaces	No. of Div.	Slide	Circle	Spaces	No. of Div.	Slide	Circle	Spaces	No. of Div.	Slide	Circle	Spaces	No. of Div.	Slide	Circle	Spaces
101	F	101	40	137	D	137	40	180	C	153	34	240	E	42	7	320	A	48	6
102	C	153	60	138	A	69	20	181	C	181	40	240	A	48	8	322	E	161	20
103	E	103	40	139	A	139	40	182	A	91	20	242	D	121	20	324	B	81	10
104	E	26	10	140	C	28	8	183	B	183	40	244	B	183	30	326	D	163	20
104	A	91	35	140	F	42	12	184	C	46	10	245	A	147	24	328	C	123	15
104	F	143	55	140	D	77	22	184	A	69	15	246	C	123	20	330	A	99	12
104	B	169	65	140	A	91	26	184	E	161	35	248	C	93	15	332	F	83	10
105	E	42	16	141	B	141	40	185	B	111	24	250	E	175	28	334	C	167	20
105	A	147	56	142	F	71	20	186	C	93	20	252	A	189	30	335	B	67	8
106	F	159	60	143	F	143	40	187	C	187	40	254	B	127	20	336	E	42	5
107	D	107	40	144	B	36	10	188	B	141	30	255	C	153	24	338	B	169	20
108	B	81	30	145	E	87	24	189	A	189	40	256	D	32	5	340	C	34	4
108	B	189	70	146	E	73	20	190	F	38	8	258	A	129	20	340	E	119	14
109	A	109	40	147	E	147	40	190	E	133	28	260	E	26	4	340	F	187	22
110	D	44	16	148	B	111	30	190	A	171	36	260	A	91	14	342	A	171	20
110	A	99	36	149	E	149	40	191	E	191	40	260	F	143	22	344	A	129	15
100	F	143	52	150	E	30	8	192	A	48	10	260	B	169	26	345	A	69	8
111	B	111	40	151	D	151	40	193	D	193	40	262	F	131	20	346	F	173	20
112	B	28	10	152	F	38	10	194	B	97	20	264	A	99	15	348	E	87	10
112	F	42	15	152	E	133	35	195	A	117	24	265	F	159	24	350	E	175	20
113	F	113	40	152	A	171	45	196	A	147	30	266	E	133	20	352	D	44	5
114	A	171	60	153	C	153	40	197	C	197	40	268	B	67	10	354	A	177	20
115	A	46	16	154	C	77	20	198	A	99	20	270	B	81	12	355	F	71	8
115	A	69	24	155	C	93	24	199	B	199	40	270	A	189	28	356	D	89	10
115	E	161	56	156	A	117	30	200	A	30	6	272	C	34	5	358	D	179	20
116	E	87	30	157	B	157	40	200	E	175	35	274	D	137	20	360	B	36	4
117	A	117	40	158	A	79	20	202	F	101	20	278	A	69	10	360	A	99	11
118	A	177	60	159	C	159	40	204	C	153	30	278	C	139	20	360	C	153	17
119	E	119	40	160	F	28	7	205	C	123	24	280	F	28	4	362	C	181	20
120	A	30	10	160	D	32	8	206	E	103	20	280	E	42	6	364	A	91	10
120	B	36	12	160	B	36	9	208	E	26	5	280	D	77	11	365	E	73	8
120	E	42	14	160	A	48	12	210	E	42	8	280	A	91	13	366	B	183	20
120	C	93	31	161	E	161	40	210	A	147	28	282	B	141	20	368	C	46	5
120	F	159	53	162	B	81	20	212	F	159	30	284	F	71	10	370	B	111	12
121	D	121	40	163	D	163	40	214	D	107	20	285	A	171	24	372	C	93	10
122	B	183	60	164	C	123	30	215	A	129	24	286	F	143	20	374	F	187	20
123	C	123	40	165	A	99	24	216	B	81	15	288	B	36	5	376	B	141	15
124	C	93	30	166	A	83	20	216	A	189	35	290	E	87	12	378	A	189	20
125	E	175	56	167	C	167	40	218	C	109	20	292	E	73	10	380	F	38	4
126	A	189	60	168	E	42	10	220	D	44	8	294	A	147	20	380	E	133	14
127	B	127	40	168	A	147	35	220	A	99	18	295	A	177	24	380	A	171	18
128	D	32	10	169	B	169	40	220	F	143	26	296	B	111	15	382	E	191	20
128	A	48	15	170	C	34	8	222	B	111	20	298	E	149	20	384	A	48	5
129	A	129	40	170	E	119	28	224	F	28	5	300	A	30	4	385	D	77	8
130	E	26	8	170	F	187	44	226	F	113	20	302	D	151	20	386	D	193	20
130	A	91	28	171	A	171	40	228	A	171	30	304	F	38	5	388	B	97	10
130	F	143	44	172	A	129	30	230	C	46	8	305	B	183	24	390	A	117	12
130	B	169	52	173	F	173	40	230	A	69	12	306	C	153	20	392	A	147	15
131	F	131	40	174	E	87	20	230	E	161	28	308	D	77	10	394	C	197	20
132	A	99	30	175	E	175	40	232	E	87	15	310	C	93	12	395	C	79	3
133	E	133	40	176	D	44	10	234	A	117	20	312	A	117	15	396	A	99	10
134	B	67	20	177	A	177	40	235	B	141	24	314	B	157	20	398	B	199	20
135	B	81	24	178	D	89	20	236	A	177	30	315	A	189	24	400	A	30	3
135	A	189	56	179	D	179	40	238	E	119	20	316	C	79	10
136	C	34	10	180	B	36	8	240	A	30	5	318	F	159	20
136	E	119	35	180	A	99	22	240	B	36	6	320	D	32	4

TABLE OF ANGULAR DIVISIONS
 Obtainable With Standard Dividing Head and Wide Range Divider
 (Use 54-hole circle on large plate—See Fig. 47, page 58)

DEGREES

Degrees	Turns of Crank B	Spaces Crank B	Degrees	Turns of Crank B	Spaces Crank B	Degrees	Turns of Crank B	Spaces Crank B	Degrees	Turns of Crank B	Spaces Crank B	Degrees	Turns of Crank B	Spaces Crank B	Degrees	Turns of Crank B	Spaces Crank B
0	0	0	1	1	1	2	2	2	3	3	3	4	4	4	5	5	5
1	1	1	2	2	2	3	3	3	4	4	4	5	5	5	6	6	6
2	2	2	3	3	3	4	4	4	5	5	5	6	6	6	7	7	7
3	3	3	4	4	4	5	5	5	6	6	6	7	7	7	8	8	8
4	4	4	5	5	5	6	6	6	7	7	7	8	8	8	9	9	9
5	5	5	6	6	6	7	7	7	8	8	8	9	9	9	10	10	10
6	6	6	7	7	7	8	8	8	9	9	9	10	10	10	11	11	11
7	7	7	8	8	8	9	9	9	10	10	10	11	11	11	12	12	12
8	8	8	9	9	9	10	10	10	11	11	11	12	12	12	13	13	13
9	9	9	10	10	10	11	11	11	12	12	12	13	13	13	14	14	14
10	10	10	11	11	11	12	12	12	13	13	13	14	14	14	15	15	15
11	11	11	12	12	12	13	13	13	14	14	14	15	15	15	16	16	16
12	12	12	13	13	13	14	14	14	15	15	15	16	16	16	17	17	17
13	13	13	14	14	14	15	15	15	16	16	16	17	17	17	18	18	18
14	14	14	15	15	15	16	16	16	17	17	17	18	18	18	19	19	19
15	15	15	16	16	16	17	17	17	18	18	18	19	19	19	20	20	20
16	16	16	17	17	17	18	18	18	19	19	19	20	20	20	21	21	21
17	17	17	18	18	18	19	19	19	20	20	20	21	21	21	22	22	22
18	18	18	19	19	19	20	20	20	21	21	21	22	22	22	23	23	23
19	19	19	20	20	20	21	21	21	22	22	22	23	23	23	24	24	24
20	20	20	21	21	21	22	22	22	23	23	23	24	24	24	25	25	25
21	21	21	22	22	22	23	23	23	24	24	24	25	25	25	26	26	26
22	22	22	23	23	23	24	24	24	25	25	25	26	26	26	27	27	27
23	23	23	24	24	24	25	25	25	26	26	26	27	27	27	28	28	28
24	24	24	25	25	25	26	26	26	27	27	27	28	28	28	29	29	29
25	25	25	26	26	26	27	27	27	28	28	28	29	29	29	30	30	30
26	26	26	27	27	27	28	28	28	29	29	29	30	30	30	31	31	31
27	27	27	28	28	28	29	29	29	30	30	30	31	31	31	32	32	32
28	28	28	29	29	29	30	30	30	31	31	31	32	32	32	33	33	33
29	29	29	30	30	30	31	31	31	32	32	32	33	33	33	34	34	34
30	30	30	31	31	31	32	32	32	33	33	33	34	34	34	35	35	35
31	31	31	32	32	32	33	33	33	34	34	34	35	35	35	36	36	36
32	32	32	33	33	33	34	34	34	35	35	35	36	36	36	37	37	37
33	33	33	34	34	34	35	35	35	36	36	36	37	37	37	38	38	38
34	34	34	35	35	35	36	36	36	37	37	37	38	38	38	39	39	39
35	35	35	36	36	36	37	37	37	38	38	38	39	39	39	40	40	40
36	36	36	37	37	37	38	38	38	39	39	39	40	40	40			
37	37	37	38	38	38	39	39	39	40	40	40						
38	38	38	39	39	39	40	40	40									
39	39	39	40	40	40												
40	40	40															

TABLE OF ANGULAR DIVISIONS . . . Obtainable With Wide Range Divider

(Use 54-hole circle on small plate—See Fig. 47, page 58)

FRACTIONS OF A DEGREE

Minutes	Seconds	Turns of Crank D	Spaces Crank D	Minutes	Seconds	Turns of Crank D	Spaces Crank D	Minutes	Seconds	Turns of Crank D	Spaces Crank D	Minutes	Seconds	Turns of Crank D	Spaces Crank D	Minutes	Seconds	Turns of Crank D	Spaces Crank D	Minutes	Seconds	Turns of Crank D	Spaces Crank D	Minutes	Seconds	Turns of Crank D	Spaces Crank D	
0	12	1	1	1	12	1	1	1	12	1	1	1	12	1	1	1	12	1	1	1	12	1	1	1	12	1	1	1
0	24	2	2	2	24	2	2	2	24	2	2	2	24	2	2	2	24	2	2	2	24	2	2	2	24	2	2	2
0	36	3	3	3	36	3	3	3	36	3	3	3	36	3	3	3	36	3	3	3	36	3	3	3	36	3	3	3
0	48	4	4	4	48	4	4	4	48	4	4	4	48	4	4	4	48	4	4	4	48	4	4	4	48	4	4	4
1	12	1	1	1	12	1	1	1	12	1	1	1	12	1	1	1	12	1	1	1	12	1	1	1	12	1	1	1
1	24	2	2	2	24	2	2	2	24	2	2	2	24	2	2	2	24	2	2	2	24	2	2	2	24	2	2	2
1	36	3	3	3	36	3	3	3	36	3	3	3	36	3	3	3	36	3	3	3	36	3	3	3	36	3	3	3
1	48	4	4	4	48	4	4	4	48	4	4	4	48	4	4	4	48	4	4	4	48	4	4	4	48	4	4	4
2	12	1	1	1	12	1	1	1	12	1	1	1	12	1	1	1	12	1	1	1	12	1	1	1	12	1	1	1
2	24	2	2	2	24	2	2	2	24	2	2	2	24	2	2	2	24	2	2	2	24	2	2	2	24	2	2	2
2	36	3	3	3	36	3	3	3	36	3	3	3	36	3	3	3	36	3	3	3	36	3	3	3	36	3	3	3
2	48	4	4	4	48	4	4	4	48	4	4	4	48	4	4	4	48	4	4	4	48	4	4	4	48	4	4	4
3	12	1	1	1	12	1	1	1	12	1	1	1	12	1	1	1	12	1	1	1	12	1	1	1	12	1	1	1
3	24	2	2	2	24	2	2	2	24	2	2	2	24	2	2	2	24	2	2	2	24	2	2	2	24	2	2	2
3	36	3	3	3	36	3	3	3	36	3	3	3	36	3	3	3	36	3	3	3	36	3	3	3	36	3	3	3
3	48	4	4	4	48	4	4	4	48	4	4	4	48	4	4	4	48	4	4	4	48	4	4	4	48	4	4	4
4	12	1	1	1	12	1	1	1	12	1	1	1	12	1	1	1	12	1	1	1	12	1	1	1	12	1	1	1
4	24	2	2	2	24	2	2	2	24	2	2	2	24	2	2	2	24	2	2	2	24	2	2	2	24	2	2	2
4	36	3	3	3	36	3	3	3	36	3	3	3	36	3	3	3	36	3	3	3	36	3	3	3	36	3	3	3
4	48	4	4	4	48	4	4	4	48	4	4	4	48	4	4	4	48	4	4	4	48	4	4	4	48	4	4	4
5	12	1	1	1	12	1	1	1	12	1	1	1	12	1	1	1	12	1	1	1	12	1	1	1	12	1	1	1
5	24	2	2	2	24	2	2	2	24	2	2	2	24	2	2	2	24	2	2	2	24	2	2	2	24	2	2	2
5	36	3	3	3	36	3	3	3	36	3	3	3	36	3	3	3	36	3	3	3	36	3	3	3	36	3	3	3
5	48	4	4	4	48	4	4	4	48	4	4	4	48	4	4	4	48	4	4	4	48	4	4	4	48	4	4	4
6	12	1	1	1	12	1	1	1	12	1	1	1	12	1	1	1	12	1	1	1	12	1	1	1	12	1	1	1
6	24	2	2	2	24	2	2	2	24	2	2	2	24	2	2	2	24	2	2	2	24	2	2	2	24	2	2	2
6	36	3	3	3	36	3	3	3	36	3	3	3	36	3	3	3	36	3	3	3	36	3	3	3	36	3	3	3
6	48	4	4	4	48	4	4	4	48	4	4	4	48	4	4	4	48	4	4	4	48	4	4	4	48	4	4	4
7	12	1	1	1	12	1	1	1	12	1	1	1	12	1	1	1	12	1	1	1	12	1	1	1	12	1	1	1
7	24	2	2	2	24	2	2	2	24	2	2	2	24	2	2	2	24	2	2	2	24	2	2	2	24	2	2	2
7	36	3	3	3	36	3	3	3	36	3	3	3	36	3	3	3	36	3	3	3	36	3	3	3	36	3	3	3
7	48	4	4	4	48	4	4	4	48	4	4	4	48	4	4	4	48	4	4	4	48	4	4	4	48	4	4	4
8	12	1	1	1	12	1	1	1	12	1	1	1	12	1	1	1	12	1	1	1	12	1	1	1	12	1	1	1
8	24	2	2	2	24	2	2	2	24	2	2	2	24	2	2	2	24	2	2	2	24	2	2	2	24	2	2	2
8	36	3	3	3	36	3	3	3	36	3	3	3	36	3	3	3	36	3	3	3	36	3	3	3	36	3	3	3
8	48	4	4	4	48	4	4	4	48	4	4	4	48	4	4	4	48	4	4	4	48	4	4	4	48	4	4	4
9	12	1	1	1	12	1	1	1	12	1	1	1	12	1	1	1	12	1	1	1	12	1	1	1	12	1	1	1
9	24	2	2	2	24	2	2	2	24	2	2	2	24	2	2	2	24	2	2	2	24	2	2	2	24	2	2	2
9	36	3	3	3	36	3	3	3	36	3	3	3	36	3	3	3	36	3	3	3	36	3	3	3	36	3	3	3
9	48	4	4	4	48	4	4	4	48	4	4	4	48	4	4	4	48	4	4	4	48	4	4	4	48	4	4	4

NOTE:—When indexing degrees and fractions of a degree, Cranks "B" and "D" in above tables indicated in figure 47 are both moved in the same direction.

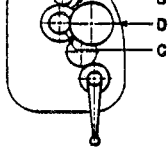

TABLE OF LEADS (2.500 to 3.800)

Lead of Spiral in Inches	Lead of Spiral in Inches				Lead of Spiral in Inches	Lead of Spiral in Inches				Lead of Spiral in Inches	Lead of Spiral in Inches			
	A	B	C	D		A	B	C	D		A	B	C	D
2.500	27	45	20	48	2.923	19	39	27	45	3.385	22	39	27	45
2.507	22	39	20	45	2.927	19	51	33	42	3.389	22	42	33	51
2.510	24	45	24	51	2.930	20	39	24	42	3.394	21	33	24	45
2.513	19	36	20	42	2.941	24	51	30	48	3.399	39	45	20	51
2.516	21	36	22	51	2.946	22	42	27	48	3.409	27	33	20	48
2.521	20	42	27	51	2.956	21	30	19	45	3.415	33	36	19	51
2.530	17	42	30	48	2.966	22	51	33	48	3.422	24	33	24	51
2.534	21	39	24	51	2.976	20	48	30	42	3.429	24	42	27	45
2.540	20	42	24	45	2.986	22	39	27	51	3.437	27	36	22	48
2.546	22	36	20	48	2.991	20	36	21	39	3.440	22	27	19	45
2.552	22	39	19	42	2.995	21	33	24	51	3.451	24	30	22	51
2.561	19	51	33	48	3.000	21	55	33	42	3.457	21	27	20	45
2.567	24	33	18	51	3.009	22	45	24	39	3.462	27	39	24	48
2.574	21	48	30	51	3.017	20	51	30	39	3.472	30	36	20	48
2.579	19	39	27	51	3.025	24	42	27	51	3.480	30	39	19	42
2.588	22	51	27	45	3.029	21	39	27	48	3.486	24	27	20	51
2.593	21	36	20	45	3.039	18	55	39	42	3.492	30	42	22	45
2.598	24	39	19	45	3.048	24	42	24	45	3.500	36	45	21	48
2.608	21	30	19	51	3.056	22	45	30	48	3.505	39	48	22	51
2.614	20	51	30	45	3.068	27	33	18	48	3.516	24	39	24	42
2.619	22	42	24	48	3.077	20	39	27	45	3.526	30	39	22	48
2.625	21	45	27	48	3.081	22	51	30	42	3.535	21	33	20	36
2.632	21	39	22	45	3.088	21	51	36	48	3.543	24	33	19	39
2.639	19	45	30	48	3.096	22	30	19	45	3.556	24	36	24	45
2.647	24	48	27	51	3.105	30	36	19	51	3.565	30	33	20	51
2.655	22	39	24	51	3.111	24	36	21	45	3.571	30	42	24	48
2.661	19	51	30	42	3.117	24	33	18	42	3.580	27	33	21	48
2.667	24	45	24	48	3.125	21	42	30	48	3.590	42	39	17	51
2.674	21	36	22	48	3.134	20	36	22	39	3.595	30	36	22	51
2.679	20	42	27	48	3.143	22	42	27	45	3.603	21	48	42	51
2.689	24	42	24	51	3.152	19	51	33	39	3.611	39	36	17	51
2.696	22	51	30	48	3.163	22	45	33	51	3.620	30	39	24	51
2.707	20	36	19	39	3.173	27	39	22	48	3.626	27	39	22	42
2.715	20	39	27	51	3.182	24	33	21	48	3.636	24	33	24	48
2.727	21	33	18	42	3.189	19	55	36	30	3.641	39	42	20	51
2.735	24	39	20	45	3.199	20	33	19	36	3.650	33	39	22	51
2.745	24	36	21	51	3.205	20	39	30	48	3.660	24	27	21	51
2.750	22	45	27	48	3.214	24	48	27	42	3.667	24	30	22	48
2.764	19	55	36	45	3.223	22	39	24	42	3.676	39	42	19	48
2.773	22	42	27	51	3.231	27	39	21	45	3.686	22	27	19	42
2.778	20	45	30	48	3.239	27	33	19	48	3.692	27	39	24	45
2.784	24	39	19	42	3.248	19	45	30	39	3.697	33	42	24	51
2.794	22	42	24	45	3.258	27	39	24	51	3.702	33	39	21	48
2.801	20	42	30	51	3.263	21	33	20	39	3.706	27	30	21	51
2.812	21	42	27	48	3.268	30	36	20	51	3.714	39	42	18	45
2.820	22	39	24	48	3.274	22	48	30	42	3.720	19	55	42	39
2.824	24	51	27	45	3.282	24	39	24	45	3.730	24	33	20	39
2.831	21	51	33	48	3.284	21	27	19	45	3.739	22	51	39	45
2.842	19	36	21	39	3.291	21	39	22	36	3.743	30	33	21	51
2.851	21	39	27	51	3.297	20	39	27	42	3.750	18	45	48	
2.857	24	42	24	48	3.309	27	48	30	51	3.753	24	27	19	45
2.866	19	39	30	51	3.318	22	51	30	39	3.761	30	39	22	45
2.876	22	51	30	45	3.329	17	55	42	39	3.765	24	30	24	51
2.879	24	33	19	48	3.333	21	42	30	45	3.770	30	36	19	42
2.885	20	39	27	48	3.346	21	51	39	48	3.775	33	36	21	51
2.896	24	39	24	51	3.353	27	30	19	51	3.782	30	42	27	51
2.903	19	45	33	48	3.361	22	45	33	48	3.788	30	33	20	48
2.910	20	36	22	42	3.369	27	33	21	51	3.792	39	45	21	48
2.917	21	45	30	48	3.377	20	55	39	42	3.800	27	30	19	45

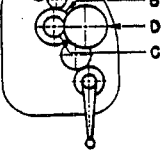
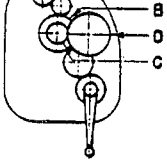

TABLE OF LEADS (3.810 to 5.025)

Lead of Spiral in Inches	Lead of Spiral in Inches				Lead of Spiral in Inches	Lead of Spiral in Inches				Lead of Spiral in Inches	Lead of Spiral in Inches			
	A	B	C	D		A	B	C	D		A	B	C	D
3.810	30	42	24	45	4.202	45	42	20	51	4.606	36	33	19	45
3.818	27	33	21	45	4.215	17	55	45	33	4.615	18	42	..	39
3.824	39	42	21	51	4.222	19	42	..	45	4.622	33	42	30	51
3.828	33	39	19	42	4.231	33	39	24	48	4.628	20	55	42	33
3.834	24	27	22	51	4.235	27	30	24	51	4.635	39	33	20	51
3.838	30	33	19	45	4.242	30	33	21	45	4.643	39	42	24	48
3.843	21	51	42	45	4.248	39	36	20	51	4.646	42	39	22	51
3.850	27	33	24	51	4.256	39	42	22	48	4.656	24	27	22	42
3.860	21	51	45	48	4.263	42	39	19	48	4.662	30	33	20	39
3.869	39	42	20	48	4.267	24	30	24	45	4.667	21	39	..	45
3.878	33	39	22	48	4.274	30	36	20	39	4.673	39	36	22	51
3.882	27	30	22	51	4.278	33	36	21	45	4.678	39	33	19	48
3.889	30	36	21	45	4.286	18	45	..	42	4.687	30	36	27	48
3.897	36	39	19	45	4.293	30	33	17	36	4.691	30	27	19	45
3.911	24	30	22	45	4.299	45	39	19	51	4.701	30	36	22	39
3.916	24	33	21	39	4.308	36	39	21	45	4.706	24	36	..	51
3.922	20	48	..	51	4.314	22	45	..	51	4.711	19	55	45	33
3.929	33	42	24	48	4.318	36	33	19	48	4.714	33	42	27	45
3.937	27	30	21	48	4.327	30	39	27	48	4.722	17	42	..	36
3.949	33	39	21	45	4.333	39	45	24	48	4.727	39	33	18	45
3.954	33	36	22	51	4.344	36	39	24	51	4.740	39	36	21	48
3.958	19	45	..	48	4.354	33	30	19	48	4.745	33	30	22	51
3.963	30	33	17	30	4.364	27	33	24	45	4.751	21	51	45	39
3.968	30	36	20	42	4.370	24	42	39	51	4.762	20	39	..	42
3.972	39	45	22	48	4.375	21	45	..	48	4.773	36	33	21	48
3.977	30	33	21	48	4.387	22	27	21	39	4.777	17	55	51	33
3.982	33	39	24	51	4.392	24	45	42	51	4.786	42	30	20	45
3.986	27	33	19	39	4.398	30	39	24	42	4.793	30	27	22	51
3.992	45	42	19	51	4.400	27	30	22	45	4.800	27	30	24	45
4.000	27	36	24	45	4.406	27	33	21	39	4.807	19	48	51	42
4.006	39	42	22	51	4.412	30	36	27	51	4.813	30	33	27	51
4.011	33	36	21	48	4.420	33	42	27	48	4.821	36	42	27	48
4.018	30	42	27	48	4.429	30	33	19	39	4.827	48	39	20	51
4.021	24	27	19	42	4.434	42	39	21	51	4.835	33	39	24	42
4.029	30	39	22	42	4.444	20	42	..	45	4.843	39	30	19	51
4.034	36	42	24	51	4.453	27	24	19	48	4.848	30	33	24	45
4.040	30	33	20	45	4.461	39	36	21	51	4.853	33	36	27	51
4.048	17	39	..	42	4.466	33	36	19	39	4.858	27	22	19	48
4.060	30	36	19	39	4.471	36	30	19	51	4.866	39	33	21	51
4.064	36	33	19	51	4.476	24	33	24	39	4.875	39	30	18	48
4.072	30	39	27	51	4.480	33	39	27	51	4.887	36	39	27	51
4.078	24	45	39	51	4.486	19	48	51	45	4.895	30	33	21	39
4.083	21	48	42	45	4.492	36	33	21	51	4.902	45	36	20	51
4.091	27	33	21	42	4.500	27	30	24	48	4.911	33	42	30	48
4.098	33	30	19	51	4.508	42	33	17	48	4.916	27	42	39	51
4.103	30	39	24	45	4.514	39	36	20	48	4.922	27	24	21	48
4.113	30	33	19	42	4.524	19	45	..	42	4.926	42	36	19	45
4.118	21	48	..	51	4.529	33	30	21	51	4.935	36	33	19	42
4.125	33	45	27	48	4.533	36	30	17	45	4.941	36	30	21	51
4.136	21	55	39	36	4.540	39	42	22	45	4.945	30	39	27	42
4.147	33	36	19	42	4.547	42	39	19	45	4.948	45	36	19	48
4.156	24	33	24	42	4.553	33	27	19	51	4.952	39	42	24	45
4.160	33	42	27	51	4.558	24	27	20	39	4.959	20	55	45	33
4.167	20	39	..	48	4.567	45	39	19	48	4.967	48	36	19	51
4.171	39	33	18	51	4.571	36	42	24	45	4.977	33	39	30	51
4.176	36	39	19	42	4.575	42	36	20	51	4.990	39	33	19	45
4.183	20	51	48	45	4.583	22	39	..	48	5.000	24	36	..	48
4.190	33	42	24	45	4.588	39	30	18	51	5.014	24	27	22	39
4.196	27	33	20	39	4.602	27	22	18	48	5.025	19	55	48	33



CINCINNATI DIAL TYPE MILLING MACHINES

TABLE OF LEADS (5.033 to 6.291)

Lead of Spiral in Inches	Lead of Spiral in Inches				Lead of Spiral in Inches	Lead of Spiral in Inches				Lead of Spiral in Inches	Lead of Spiral in Inches			
	A	B	C	D		A	B	C	D		A	B	C	D
5.033	42	36	22	51	5.440	33	30	27	42	5.882	30	36	..	51
5.038	42	33	19	48	5.444	42	36	21	45	5.887	48	33	17	42
5.042	33	30	22	48	5.455	36	33	24	48	5.893	33	36	17	42
5.048	45	39	21	48	5.469	45	36	21	48	5.903	55	33	17	48
5.056	39	36	21	45	5.481	27	24	19	39	5.911	42	30	19	45
5.065	39	33	18	42	5.489	39	30	19	45	5.921	30	19	18	48
5.068	21	51	48	39	5.495	45	39	20	42	5.926	24	27	24	36
5.077	33	39	27	45	5.500	33	36	27	45	5.934	36	39	27	42
5.080	45	33	19	51	5.510	27	21	18	42	5.939	42	33	21	45
5.085	42	36	17	39	5.515	30	33	21	45	5.948	39	27	21	51
5.091	36	33	21	45	5.527	19	55	48	30	5.954	33	27	19	39
5.098	39	36	24	51	5.538	36	39	27	45	5.961	48	30	19	51
5.104	42	36	21	48	5.546	33	21	18	51	5.966	45	33	21	48
5.114	30	33	27	48	5.552	27	22	19	42	5.975	33	27	22	45
5.123	33	24	19	51	5.556	20	39	36	36	5.983	42	36	20	39
5.128	20	42	..	39	5.561	39	33	24	51	5.989	42	33	24	51
5.135	20	51	55	42	5.568	42	33	21	48	5.994	51	30	22	48
5.143	36	42	27	45	5.573	30	19	18	51	6.000	27	39	..	45
5.147	45	36	21	51	5.581	39	33	17	36	6.010	42	33	17	36
5.152	17	45	..	33	5.587	22	45	48	42	6.019	39	27	20	48
5.156	33	36	27	48	5.594	30	33	24	39	6.027	27	42	45	48
5.160	33	27	19	45	5.600	36	30	21	45	6.032	48	36	19	42
5.170	39	33	21	48	5.608	39	30	22	51	6.039	42	30	22	51
5.176	51	39	19	48	5.615	45	33	21	51	6.044	33	39	30	42
5.185	42	36	20	45	5.625	27	36	..	48	6.050	36	21	18	51
5.192	36	39	27	45	5.630	48	36	19	45	6.054	39	24	19	51
5.195	30	33	24	42	5.641	22	42	..	39	6.058	27	24	21	39
5.200	39	30	18	45	5.647	36	30	24	51	6.061	20	42	..	33
5.208	45	36	20	48	5.657	42	33	20	45	6.067	39	30	21	45
5.216	42	30	19	51	5.664	39	27	20	51	6.071	45	30	17	42
5.223	27	48	39	42	5.675	39	36	22	42	6.090	45	36	19	39
5.229	48	36	20	51	5.682	45	33	20	48	6.095	24	45	48	42
5.238	22	45	42	42	5.687	39	30	21	48	6.100	42	27	20	51
5.241	42	33	21	51	5.692	55	36	19	51	6.107	27	20	19	42
5.250	27	30	21	36	5.698	30	27	20	39	6.111	22	42	..	36
5.255	17	55	51	30	5.704	42	36	22	45	6.118	39	30	24	51
5.260	27	22	18	42	5.714	24	39	42	42	6.125	42	30	21	48
5.265	42	39	22	45	5.718	30	27	19	48	6.130	33	19	18	51
5.272	33	27	22	51	5.727	27	22	21	45	6.136	36	33	27	48
5.278	19	42	..	36	5.735	39	24	18	51	6.141	48	33	19	45
5.288	33	39	30	48	5.744	42	39	24	45	6.154	24	42	..	39
5.294	27	36	..	51	5.752	33	27	24	51	6.162	33	21	20	51
5.303	42	33	20	48	5.758	19	42	..	33	6.169	45	33	19	42
5.312	51	36	18	48	5.762	33	30	22	42	6.176	36	24	21	51
5.322	30	21	19	51	5.769	36	39	30	48	6.182	51	33	18	45
5.333	24	39	..	45	5.775	36	33	27	51	6.190	39	36	24	42
5.339	19	55	51	33	5.782	30	21	17	42	6.198	51	36	21	48
5.347	42	36	22	48	5.789	33	19	17	51	6.205	33	30	22	39
5.353	39	30	21	51	5.795	51	33	18	48	6.209	45	27	19	51
5.359	33	30	19	39	5.804	30	42	39	48	6.222	42	36	24	45
5.369	27	22	21	48	5.807	21	51	55	39	6.231	39	27	22	51
5.378	33	30	22	45	5.816	27	21	19	42	6.237	39	33	19	36
5.385	21	42	..	39	5.820	30	27	22	42	6.250	30	36	..	48
5.392	45	36	22	51	5.824	33	30	27	51	6.257	39	33	27	51
5.398	45	33	19	48	5.833	21	39	..	36	6.268	30	27	22	39
5.413	30	27	19	39	5.844	30	33	27	42	6.275	48	33	22	51
5.419	48	33	19	51	5.854	33	21	19	51	6.282	42	36	21	39
5.429	36	30	19	42	5.864	30	27	19	36	6.286	33	21	18	45
5.432	30	27	22	45	5.874	36	33	21	39	6.291	21	51	55	36

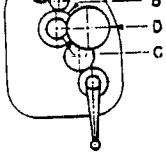
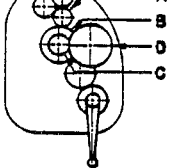

TABLE OF LEADS (6.296 to 7.483)

Lead of Spiral in Inches					Lead of Spiral in Inches					Lead of Spiral in Inches				
	A	B	C	D		A	B	C	D		A	B	C	D
6.296	17	45	..	27	6.699	33	24	19	39	7.059	45	30	24	51
6.303	39	33	24	45	6.710	42	27	22	51	7.062	39	27	22	45
6.316	36	19	17	51	6.713	36	33	24	39	7.071	33	30	27	44
6.319	39	27	21	48	6.717	42	33	19	36	7.083	17	45	..	22
6.333	19	42	..	30	6.722	33	24	22	45	7.086	48	33	19	39
6.340	48	33	17	39	6.729	51	30	19	48	7.091	39	33	27	45
6.346	33	36	27	39	6.734	30	27	20	33	7.105	36	19	18	48
6.349	48	36	20	42	6.738	42	33	27	51	7.112	42	22	19	51
6.353	36	30	27	51	6.741	39	27	21	45	7.125	36	20	19	48
6.356	39	30	22	45	6.746	55	33	17	42	7.130	42	27	22	48
6.364	21	42	..	33	6.750	36	30	27	48	7.136	51	27	17	45
6.375	51	30	18	48	6.756	48	30	19	45	7.143	30	39	..	42
6.387	36	21	19	51	6.761	51	33	21	48	7.152	33	19	21	51
6.393	22	45	51	39	6.769	33	30	24	39	7.159	42	33	27	48
6.400	36	30	24	45	6.774	60	33	19	51	7.175	30	22	17	42
6.405	42	27	21	51	6.779	33	21	22	51	7.179	42	36	24	39
6.410	45	36	20	39	6.786	45	30	19	42	7.190	33	27	30	51
6.417	36	33	30	51	6.790	30	27	22	36	7.200	36	30	27	45
6.420	39	27	20	45	6.797	39	27	24	51	7.206	42	24	21	51
6.429	27	39	..	42	6.806	42	27	21	48	7.212	51	33	21	45
6.439	45	33	17	36	6.810	39	30	22	42	7.222	39	27	24	48
6.447	22	42	48	39	6.818	36	33	30	48	7.232	33	17	19	51
6.451	33	27	19	36	6.821	42	30	19	39	7.240	30	39	48	51
6.462	42	39	27	45	6.830	55	30	19	51	7.245	39	19	18	51
6.465	48	33	20	45	6.838	48	36	20	39	7.253	36	39	33	42
6.471	33	36	..	51	6.845	24	51	45	33	7.259	42	27	21	45
6.477	36	22	19	48	6.853	42	33	21	30	7.265	45	27	17	39
6.481	42	27	20	48	6.857	36	30	24	42	7.273	24	42	..	33
6.490	27	39	45	48	6.863	45	27	21	51	7.279	33	24	27	51
6.494	45	33	20	42	6.869	48	33	17	36	7.283	39	21	20	51
6.500	30	30	24	48	6.875	33	30	20	48	7.286	51	30	18	42
6.513	33	19	18	48	6.878	39	27	20	42	7.292	45	27	21	48
6.519	33	27	24	45	6.882	39	30	27	51	7.299	39	22	21	51
6.525	51	33	19	45	6.894	39	33	21	36	7.308	45	30	19	30
6.531	33	20	19	48	6.902	48	30	22	51	7.313	39	20	18	48
6.536	45	27	20	51	6.908	30	19	21	48	7.320	42	27	24	51
6.545	36	33	27	45	6.914	42	27	20	45	7.326	30	21	20	39
6.555	39	21	18	51	6.919	39	21	19	51	7.333	33	36	..	45
6.563	36	24	21	48	6.923	27	42	..	39	7.341	19	55	51	24
6.568	42	27	19	45	6.926	48	33	20	42	7.347	27	21	24	42
6.577	39	21	17	48	6.933	39	30	24	45	7.353	45	24	20	51
6.581	42	36	22	39	6.939	36	21	17	42	7.368	30	19	21	45
6.588	42	30	24	51	6.944	45	27	20	48	7.385	36	30	24	39
6.593	45	39	24	42	6.947	33	19	18	45	7.389	42	24	19	45
6.600	33	30	27	45	6.952	39	33	30	51	7.395	33	21	24	51
6.608	27	22	21	39	6.955	18	55	51	24	7.403	36	22	19	42
6.611	42	24	17	45	6.960	30	21	19	39	7.407	20	45	..	27
6.618	30	24	27	51	6.964	39	36	27	42	7.412	42	30	27	51
6.623	51	33	18	42	6.968	33	39	42	51	7.418	45	30	27	42
6.632	27	19	21	45	6.972	48	27	20	51	7.424	42	33	21	36
6.635	33	21	19	45	6.984	48	36	22	42	7.429	39	30	24	42
6.643	45	33	19	39	6.993	45	33	20	39	7.438	51	30	21	48
6.648	39	33	27	48	7.000	21	42	..	30	7.444	33	19	18	42
6.667	30	36	..	45	7.010	39	24	22	51	7.451	42	21	19	51
6.679	33	20	17	42	7.013	36	33	27	42	7.459	48	33	20	39
6.684	55	36	21	48	7.018	30	19	20	45	7.464	33	20	19	42
6.687	36	19	18	51	7.030	33	19	17	42	7.469	33	27	22	36
6.691	39	24	21	51	7.037	19	45	..	27	7.474	36	17	18	51
6.696	30	42	45	48	7.051	30	24	22	39	7.483	30	21	22	42



CINCINNATI DIAL TYPE MILLING MACHINES

TABLE OF LEADS (7.487 to 8.766)

Lead of Spiral in Inches	Lead of Spiral in Inches				Lead of Spiral in Inches	Lead of Spiral in Inches				Lead of Spiral in Inches	Lead of Spiral in Inches			
	A	B	C	D		A	B	C	D		A	B	C	D
7.487	42	33	30	51	7.889	36	17	19	51	8.319	33	21	27	51
7.492	33	19	22	51	7.897	42	30	22	39	8.322	51	33	21	39
7.500	36	33	..	48	7.901	48	27	20	45	8.333	30	39	..	36
7.508	48	27	19	45	7.908	33	18	22	51	8.342	39	22	24	51
7.517	39	21	17	42	7.912	48	39	27	42	8.352	42	22	21	48
7.521	48	36	22	39	7.917	19	42	..	24	8.357	39	30	27	42
7.529	51	33	19	39	7.933	51	30	21	45	8.366	48	27	24	51
7.538	42	30	21	39	7.944	39	36	33	45	8.374	33	17	22	51
7.549	42	24	22	51	7.955	42	33	30	48	8.381	48	30	22	42
7.552	36	33	27	39	7.964	33	39	48	51	8.388	55	27	21	51
7.557	42	22	19	48	7.972	36	22	19	39	8.392	36	33	30	39
7.563	33	20	22	48	7.977	42	27	20	39	8.400	42	30	27	45
7.568	39	27	22	42	7.983	45	21	19	51	8.403	45	21	20	51
7.571	33	19	17	39	7.988	55	27	20	51	8.412	39	30	33	51
7.578	60	33	20	48	7.993	33	17	21	51	8.422	45	22	21	51
7.583	39	30	21	36	8.000	36	33	..	45	8.426	39	27	21	36
7.589	55	27	19	51	8.011	39	21	22	51	8.438	36	24	27	48
7.597	39	33	27	42	8.016	33	19	18	39	8.444	48	24	19	45
7.600	36	20	19	45	8.021	42	24	22	48	8.452	39	19	21	51
7.605	42	27	22	45	8.028	51	24	17	45	8.462	33	36	..	39
7.612	33	17	20	51	8.038	45	36	27	42	8.471	36	17	18	45
7.615	33	30	27	39	8.042	48	27	19	42	8.482	45	24	19	42
7.619	48	30	20	42	8.050	39	19	20	51	8.488	55	27	20	48
7.623	39	27	19	36	8.059	30	21	22	39	8.493	33	17	21	48
7.628	42	24	17	39	8.063	55	27	19	48	8.497	39	27	30	51
7.636	36	22	21	45	8.067	36	21	24	51	8.502	30	19	21	39
7.639	33	27	30	48	8.072	39	18	19	51	8.512	39	24	22	42
7.646	51	27	17	42	8.077	45	30	21	39	8.515	48	21	19	51
7.656	42	24	21	48	8.081	60	33	20	45	8.523	45	22	20	48
7.669	48	27	22	51	8.088	33	24	30	51	8.531	39	20	21	48
7.677	36	27	19	33	8.095	17	45	..	21	8.538	55	24	19	51
7.684	33	17	19	48	8.105	33	19	21	45	8.545	51	27	19	42
7.692	30	36	..	39	8.114	21	55	51	24	8.553	39	19	20	48
7.697	39	19	18	48	8.120	55	33	19	39	8.556	42	30	22	36
7.700	33	20	21	45	8.128	48	22	19	51	8.571	36	33	..	42
7.704	39	27	24	45	8.143	36	20	19	42	8.576	39	24	19	36
7.714	36	30	27	42	8.148	22	42	..	27	8.594	33	24	30	48
7.721	45	24	21	51	8.157	51	33	19	36	8.603	39	24	27	51
7.727	17	45	..	22	8.163	30	21	24	42	8.615	42	30	24	39
7.734	33	24	27	48	8.167	42	24	21	45	8.627	42	21	22	51
7.738	39	36	30	42	8.173	45	24	17	39	8.636	19	45	..	22
7.741	55	30	19	45	8.182	27	39	..	33	8.643	33	20	22	42
7.749	48	27	17	39	8.196	33	17	19	45	8.654	45	36	27	39
7.758	48	33	24	45	8.205	48	36	24	39	8.661	48	27	19	39
7.765	36	30	33	51	8.211	39	19	18	45	8.667	39	33	..	45
7.778	21	42	..	27	8.231	33	21	22	42	8.673	45	21	17	42
7.792	51	30	22	48	8.235	48	24	21	51	8.684	33	19	24	48
7.800	39	30	27	45	8.242	51	33	24	45	8.693	51	22	18	48
7.813	45	24	20	48	8.250	33	20	24	48	8.708	33	20	19	36
7.822	48	30	22	45	8.254	39	27	24	42	8.715	60	27	20	51
7.829	42	19	17	48	8.259	36	19	17	39	8.720	36	17	21	51
7.832	42	33	24	39	8.264	51	27	21	48	8.727	36	30	24	33
7.841	39	21	19	45	8.273	39	30	21	33	8.730	33	27	30	42
7.846	51	30	18	39	8.282	51	30	19	39	8.739	39	21	24	51
7.857	33	36	..	42	8.289	36	19	21	48	8.745	27	19	24	39
7.861	42	22	21	51	8.296	42	27	24	45	8.750	21	45	..	24
7.870	45	27	17	36	8.308	36	17	20	51	8.754	39	27	20	33
7.875	42	30	27	48	8.308	36	30	27	39	8.758	51	22	17	45
7.879	39	33	30	45	8.312	48	33	24	42	8.766	45	33	27	42

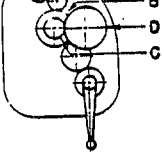
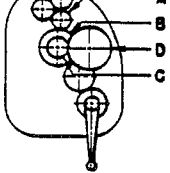

TABLE OF LEADS (8.769 to 10.094)

Lead of Spiral in Inches	Lead of Spiral in Inches				Lead of Spiral in Inches	Lead of Spiral in Inches				Lead of Spiral in Inches	Lead of Spiral in Inches			
	A	B	C	D		A	B	C	D		A	B	C	D
8.769	36	20	19	39	9.184	30	21	27	42	9.630	39	27	24	36
8.775	42	27	22	39	9.192	39	27	21	33	9.636	42	19	17	39
8.782	33	17	19	42	9.202	51	27	19	39	9.643	36	24	27	42
8.787	55	27	22	51	9.205	36	22	27	48	9.651	48	21	19	45
8.791	30	21	24	39	9.211	42	19	20	48	9.659	39	19	24	51
8.796	60	27	19	48	9.215	55	27	19	42	9.670	33	21	24	39
8.800	33	20	24	45	9.231	36	33	39	36	9.676	55	24	19	45
8.811	42	33	27	39	9.236	42	24	19	36	9.686	30	17	19	45
8.815	51	27	21	45	9.244	45	21	22	51	9.692	42	30	27	39
8.821	39	20	19	42	9.253	45	22	19	42	9.700	55	27	20	42
8.827	39	27	22	36	9.259	60	27	20	48	9.706	36	24	33	51
8.831	48	22	17	42	9.273	51	33	27	45	9.714	51	21	18	45
8.839	33	24	27	42	9.281	33	20	27	48	9.722	45	27	21	36
8.844	39	21	20	42	9.288	45	19	20	51	9.728	39	21	22	42
8.854	55	22	17	48	9.297	51	24	21	48	9.740	45	33	30	42
8.864	39	33	36	48	9.301	42	22	19	39	9.744	48	24	19	39
8.867	42	20	19	45	9.308	33	20	22	39	9.750	39	30	27	36
8.882	45	19	18	48	9.314	60	24	19	51	9.757	55	21	19	51
8.889	24	42	27	27	9.333	42	30	24	36	9.770	33	19	27	48
8.897	33	17	22	48	9.341	45	21	17	39	9.778	55	30	24	45
8.905	51	30	22	42	9.346	30	27	33	51	9.788	51	30	19	33
8.909	42	22	21	45	9.351	48	33	27	42	9.796	36	21	24	42
8.916	36	19	24	51	9.356	30	24	19	33	9.800	42	20	21	45
8.922	39	18	21	51	9.375	36	24	30	48	9.808	51	24	18	39
8.929	45	24	20	42	9.385	39	22	27	51	9.818	36	20	18	33
8.932	55	30	19	39	9.402	33	27	30	39	9.825	42	19	20	45
8.938	39	20	22	48	9.408	39	19	22	48	9.832	39	21	27	51
8.941	36	17	19	46	9.412	42	21	24	51	9.844	42	24	27	48
8.947	17	45	19	19	9.421	36	22	19	33	9.852	42	18	19	45
8.951	48	33	24	39	9.429	33	21	27	45	9.860	48	21	22	51
8.956	42	27	19	33	9.436	55	24	21	51	9.868	45	19	20	48
8.964	48	21	20	51	9.441	45	33	27	39	9.872	55	30	21	39
8.972	51	24	19	45	9.446	39	17	21	51	9.877	48	27	20	36
8.980	39	19	21	48	9.455	39	30	24	33	9.882	36	17	21	45
8.990	33	39	51	48	9.474	18	45	19	19	9.886	55	24	22	51
9.000	27	42	30	30	9.481	48	27	24	45	9.890	30	21	27	39
9.015	42	22	17	36	9.490	33	17	22	45	9.894	51	27	22	42
9.023	30	19	24	42	9.500	19	45	20	20	9.900	33	20	27	45
9.031	51	20	17	48	9.506	55	27	21	45	9.907	48	19	20	51
9.048	19	45	21	21	9.510	51	33	24	39	9.917	30	22	24	33
9.053	55	27	20	45	9.519	33	24	27	39	9.926	45	24	27	51
9.059	42	30	33	51	9.524	20	45	21	21	9.931	39	24	22	36
9.066	27	42	55	39	9.533	30	20	22	45	9.935	51	33	27	42
9.071	55	24	19	48	9.536	42	19	22	51	9.955	33	17	20	39
9.076	36	21	27	51	9.545	21	45	20	22	9.959	55	27	22	45
9.081	39	17	19	48	9.549	55	24	20	48	9.965	36	17	24	51
9.091	30	36	33	33	9.559	39	24	30	51	9.969	51	27	10	36
9.098	33	19	22	42	9.563	51	20	18	48	9.972	39	22	27	48
9.102	42	19	21	51	9.573	42	27	24	39	9.989	55	24	17	39
9.107	51	36	27	42	9.579	39	19	21	45	10.000	24	45	20	24
9.117	48	27	20	39	9.586	45	19	17	42	10.026	55	24	21	48
9.123	39	19	20	45	9.590	51	30	22	39	10.031	36	19	27	51
9.135	45	24	19	39	9.596	45	27	19	33	10.037	39	17	21	48
9.141	39	24	27	48	9.600	48	30	27	45	10.053	60	27	19	42
9.148	39	18	19	45	9.603	55	30	22	42	10.065	42	27	33	51
9.150	42	27	30	51	9.608	42	18	21	51	10.070	36	22	24	39
9.154	51	30	21	39	9.613	51	24	19	42	10.076	42	22	19	36
9.167	33	39	36	36	9.619	55	27	17	36	10.084	45	21	24	51
9.176	39	30	36	51	9.625	42	20	22	48	10.094	51	20	19	48



CINCINNATI DIAL TYPE MILLING MACHINES

TABLE OF LEADS (10.096 to 11.692)

Lead of Spiral in Inches	A	B	C	D	Lead of Spiral in Inches	A	B	C	D	Lead of Spiral in Inches	A	B	C	D
	10.096	45	24	21		39	10.625	51	24		18	36	11.158	51
10.102	33	21	27	42	10.636	39	22	27	45	11.165	55	24	19	39
10.107	42	22	27	51	10.644	60	21	19	51	11.172	39	24	33	48
10.119	55	22	17	42	10.655	51	27	22	39	11.176	19	45	17	17
10.125	36	20	27	48	10.658	36	19	27	48	11.184	45	19	17	36
10.133	48	20	19	45	10.670	55	27	22	42	11.189	48	33	30	39
10.142	51	22	21	48	10.688	33	19	24	39	11.200	42	30	36	45
10.150	30	19	27	42	10.694	42	27	33	48	11.204	55	24	22	45
10.156	39	24	30	48	10.699	51	22	18	39	11.211	36	17	27	51
10.160	60	22	19	51	10.706	42	30	39	51	11.216	39	17	22	45
10.168	33	17	22	42	10.714	33	22	30	42	11.224	45	21	22	42
10.173	42	17	21	51	10.739	42	22	27	48	11.230	42	22	30	51
10.185	55	27	24	48	10.744	39	22	20	33	11.250	27	42	24	24
10.200	51	30	27	45	10.751	55	27	19	36	11.259	48	18	19	45
10.208	42	24	21	36	10.756	48	21	24	51	11.278	45	19	20	42
10.217	45	19	22	51	10.769	42	33	39	39	11.282	55	30	24	39
10.227	36	22	30	48	10.774	48	27	20	33	11.294	51	22	19	39
10.236	48	27	19	33	10.784	45	27	33	51	11.298	55	21	22	51
10.252	55	19	17	48	10.794	51	27	24	42	11.308	42	20	21	39
10.263	39	19	24	48	10.800	36	20	27	45	11.313	42	27	24	33
10.271	55	21	20	51	10.809	42	17	21	48	11.317	55	27	20	36
10.280	42	22	21	39	10.818	51	22	21	45	11.324	42	24	33	51
10.288	48	30	27	42	10.822	55	18	17	48	11.329	36	22	27	39
10.294	55	22	21	51	10.827	36	19	24	42	11.336	42	19	20	39
10.303	51	33	24	36	10.833	39	33	36	36	11.345	45	21	27	51
10.313	45	30	33	48	10.855	45	19	22	48	11.352	55	19	20	51
10.324	45	19	17	39	10.860	30	17	24	39	11.364	45	33	30	36
10.340	48	21	19	42	10.867	39	19	27	51	11.368	36	19	27	48
10.353	51	24	19	39	10.875	51	27	19	33	11.375	42	30	39	45
10.362	45	19	21	48	10.884	48	21	20	42	11.383	55	18	19	51
10.370	42	27	24	36	10.889	42	18	21	45	11.396	60	27	20	39
10.378	39	17	19	42	10.900	45	17	21	51	11.407	42	27	33	45
10.385	45	30	27	39	10.909	36	39	33	33	11.416	55	21	17	39
10.390	48	22	20	42	10.913	55	24	20	42	11.423	33	20	27	39
10.400	39	30	36	45	10.919	33	17	27	48	11.429	24	45	27	21
10.408	51	21	18	42	10.924	39	21	30	51	11.435	39	18	19	36
10.413	36	22	21	33	10.931	30	19	27	39	11.442	51	24	21	39
10.421	33	19	27	45	10.940	48	27	24	39	11.455	42	22	27	45
10.431	42	17	19	45	10.950	33	17	22	39	11.471	30	17	24	48
10.440	45	21	19	39	10.962	45	20	19	39	11.483	36	19	20	33
10.446	55	27	20	39	10.969	55	27	21	39	11.491	55	27	22	39
10.452	33	17	21	39	10.980	42	18	24	51	11.503	48	18	22	51
10.462	48	20	17	39	10.986	51	21	19	42	11.515	60	22	19	45
10.476	22	45	21	21	10.992	42	22	19	33	11.529	42	17	21	45
10.490	45	33	30	39	11.000	33	42	30	30	11.538	45	30	39	39
10.500	21	45	20	20	11.014	45	22	21	39	11.546	39	19	27	48
10.505	39	27	24	33	11.020	36	21	27	42	11.556	39	27	36	45
10.515	39	24	33	51	11.029	45	24	30	51	11.570	42	22	20	33
10.519	36	22	27	42	11.039	51	33	30	42	11.579	22	45	19	19
10.528	20	45	19	19	11.053	21	45	19	19	11.591	51	22	21	42
10.547	45	24	27	48	11.058	55	21	19	45	11.607	39	24	30	42
10.556	19	45	18	18	11.073	48	17	20	51	11.611	55	20	19	45
10.577	33	24	30	39	11.080	39	22	30	48	11.624	51	27	24	39
10.582	60	27	20	42	11.092	36	21	33	51	11.636	48	22	24	45
10.588	18	45	17	17	11.111	30	39	27	27	11.647	33	17	27	45
10.593	39	27	33	45	11.123	39	33	48	51	11.660	36	19	24	39
10.601	55	21	17	42	11.131	51	24	22	42	11.667	42	33	36	36
10.607	33	20	27	42	11.136	42	22	21	36	11.688	60	33	27	42
10.614	33	19	22	36	11.146	36	19	30	51	11.692	48	20	19	39

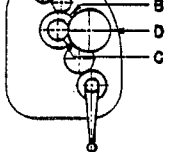

TABLE OF LEADS (11.703 to 13.303)

Lead of Spiral in Inches	Lead of Spiral in Inches				Lead of Spiral in Inches	Lead of Spiral in Inches				Lead of Spiral in Inches	Lead of Spiral in Inches			
	A	B	C	D		A	B	C	D		A	B	C	D
11.703	42	19	27	51	12.217	45	17	18	39	12.745	45	27	39	51
11.719	45	24	30	48	12.222	33	39	..	27	12.750	51	30	27	36
11.729	39	19	24	42	12.235	51	22	19	36	12.759	55	21	19	39
11.733	48	20	22	45	12.245	45	21	24	42	12.768	39	24	33	42
11.743	51	19	21	48	12.250	42	20	21	36	12.773	48	17	19	42
11.748	42	22	24	39	12.273	27	42	..	22	12.784	45	22	30	48
11.752	55	24	20	39	12.281	42	19	20	36	12.795	60	27	19	33
11.765	20	48	..	17	12.303	51	19	22	48	12.800	48	20	24	45
11.769	51	30	27	39	12.308	42	21	24	39	12.806	55	17	19	48
11.777	45	22	19	33	12.316	39	19	27	45	12.817	51	21	19	36
11.789	42	19	24	45	12.325	55	21	24	51	12.821	55	22	20	39
11.806	55	22	17	36	12.338	60	22	19	42	12.829	39	19	30	48
11.813	42	20	27	48	12.346	60	27	20	36	12.834	48	22	30	51
11.818	39	36	..	33	12.353	21	45	..	17	12.857	27	45	..	21
11.831	51	21	19	39	12.364	51	22	24	45	12.866	55	19	20	45
11.842	45	19	24	48	12.375	33	24	27	30	12.879	51	33	30	36
11.846	42	30	33	39	12.381	39	27	36	42	12.891	45	24	33	48
11.852	48	27	24	36	12.389	51	19	18	39	12.896	45	17	19	39
11.863	33	17	22	36	12.397	45	22	20	33	12.904	39	17	27	48
11.868	36	21	27	39	12.409	39	22	21	30	12.919	30	19	27	33
11.875	51	17	19	48	12.418	60	18	19	51	12.923	42	20	24	39
11.883	55	27	21	36	12.423	51	20	19	39	12.929	48	27	24	33
11.889	48	19	24	51	12.434	42	19	27	48	12.941	22	45	..	17
11.895	42	27	39	51	12.440	55	20	19	42	12.952	51	21	24	45
11.900	51	20	21	45	12.449	55	27	22	36	12.963	55	27	21	33
11.905	45	27	30	42	12.457	45	17	24	51	12.981	45	24	27	39
11.912	36	17	27	48	12.462	36	20	27	39	12.991	48	18	19	39
11.917	39	30	33	36	12.467	51	20	22	45	13.000	39	36	..	30
11.922	48	17	19	45	12.472	55	21	20	42	13.017	45	22	21	33
11.932	42	22	30	48	12.479	33	17	27	42	13.026	36	19	33	48
11.939	39	21	27	42	12.487	55	19	22	51	13.032	36	17	24	39
11.946	33	17	24	39	12.500	45	33	..	36	13.040	51	22	27	48
11.953	51	24	27	48	12.513	39	22	36	51	13.061	48	21	24	42
11.963	51	18	19	45	12.525	51	19	21	45	13.072	60	18	20	51
11.973	48	21	22	42	12.536	55	27	24	39	13.080	42	17	27	51
11.983	55	18	20	51	12.544	39	19	22	36	13.095	45	27	33	42
11.987	51	24	22	39	12.549	48	18	24	51	13.109	39	21	36	51
12.000	36	39	..	30	12.557	39	33	51	48	13.117	36	19	27	39
12.004	55	21	22	48	12.564	42	18	21	39	13.125	42	24	36	48
12.017	39	21	33	51	12.571	36	21	33	45	13.131	39	27	30	33
12.024	33	19	27	39	12.582	55	18	21	51	13.149	45	22	27	42
12.031	42	24	33	48	12.587	45	33	36	39	13.162	42	27	33	39
12.037	39	27	30	36	12.593	51	27	24	36	13.176	42	17	24	45
12.042	51	20	17	36	12.600	42	20	27	45	13.181	55	18	22	51
12.053	55	17	19	51	12.606	39	33	48	45	13.187	36	21	30	39
12.057	36	19	21	33	12.618	55	19	17	39	13.195	39	19	27	42
12.063	60	21	19	45	12.632	24	45	..	19	13.200	36	20	33	45
12.074	39	19	30	51	12.639	42	27	39	48	13.209	39	17	19	33
12.088	33	21	30	39	12.656	45	20	27	48	13.217	42	22	27	39
12.095	55	24	19	36	12.662	39	22	30	42	13.223	48	22	20	33
12.101	48	21	27	51	12.667	60	20	19	45	13.233	48	19	22	42
12.108	39	17	19	36	12.675	51	19	17	36	13.241	39	27	33	36
12.115	42	24	27	39	12.687	55	17	20	51	13.247	51	22	24	42
12.121	60	22	20	45	12.692	45	30	33	30	13.263	42	19	27	45
12.133	42	30	39	45	12.698	18	27	30	42	13.268	55	19	22	48
12.149	42	22	21	33	12.706	36	17	27	45	13.281	51	24	30	48
12.179	60	24	19	39	12.721	51	21	22	42	13.287	48	17	24	51
12.188	39	22	33	48	12.727	42	36	..	33	13.295	39	22	36	48
12.201	45	19	17	33	12.731	55	24	20	36	13.303	42	17	21	39

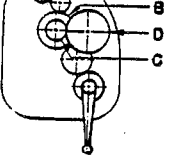

TABLE OF LEADS (13.322 to 15.231)

Lead of Spiral in Inches	A B C D				Lead of Spiral in Inches	A B C D				Lead of Spiral in Inches	A B C D			
	A	B	C	D		A	B	C	D		A	B	C	D
13.322	45	19	27	48	13.929	39	22	33	42	14.592	39	21	33	42
13.333	48	33	..	36	13.937	42	17	22	39	14.599	42	22	39	51
13.347	51	22	19	33	13.956	55	17	22	51	14.609	51	24	33	48
13.357	51	20	22	42	13.971	60	17	19	48	14.615	60	20	19	39
13.368	55	24	21	36	13.986	60	33	30	39	14.625	39	30	27	24
13.375	48	19	27	51	14.000	42	36	..	30	14.636	55	17	19	42
13.382	42	24	39	51	14.005	55	24	22	36	14.641	51	19	18	33
13.388	36	22	27	33	14.014	45	17	27	51	14.652	60	21	20	39
13.397	55	20	19	39	14.020	39	18	33	51	14.661	36	17	27	30
13.406	39	20	33	48	14.026	48	22	27	42	14.667	55	20	24	45
13.421	51	19	24	48	14.035	60	19	20	45	14.682	51	20	19	33
13.431	55	21	20	39	14.060	51	19	22	42	14.694	48	21	27	42
13.439	33	17	27	39	14.066	48	21	24	39	14.706	45	18	30	51
13.445	48	21	30	51	14.074	60	18	19	45	14.712	51	24	27	39
13.458	51	20	19	36	14.103	60	24	22	39	14.727	36	22	27	30
13.468	60	27	20	33	14.112	39	19	33	48	14.737	42	19	30	45
13.474	48	19	24	45	14.118	24	48	..	17	14.748	39	17	27	42
13.481	42	27	39	45	14.141	42	27	30	33	14.752	51	22	21	33
13.492	51	27	30	42	14.152	55	19	22	45	14.769	48	20	24	39
13.500	27	42	..	20	14.161	45	22	27	39	14.774	55	21	22	39
13.509	42	19	22	36	14.167	51	24	30	45	14.790	48	21	33	51
13.523	51	24	21	33	14.182	39	30	36	33	14.803	45	19	30	48
13.534	36	19	30	42	14.211	27	42	..	19	14.808	42	24	33	39
13.542	45	27	39	48	14.219	42	24	39	48	14.815	55	27	24	33
13.571	60	20	19	42	14.225	42	17	19	33	14.824	42	17	27	45
13.580	55	27	24	36	14.251	48	19	22	39	14.835	45	21	27	39
13.600	51	20	24	45	14.259	42	27	33	36	14.841	51	27	33	42
13.611	42	18	21	36	14.266	51	22	24	39	14.850	33	20	27	30
13.622	55	19	24	51	14.286	30	39	..	21	14.861	48	19	30	51
13.636	45	36	..	33	14.300	39	20	33	45	14.875	51	20	21	36
13.660	55	17	19	45	14.316	51	19	24	45	14.886	55	18	19	39
13.670	55	19	17	36	14.338	45	24	39	51	14.890	45	17	27	48
13.675	48	27	30	39	14.344	51	20	27	48	14.896	39	36	33	24
13.684	39	19	30	45	14.351	39	33	51	42	14.903	51	22	27	42
13.700	51	21	22	39	14.359	42	27	36	39	14.928	39	19	24	33
13.714	48	21	27	45	14.379	55	18	24	51	14.938	55	27	22	30
13.719	55	21	22	42	14.385	51	30	33	39	14.945	51	21	24	39
13.725	45	27	42	51	14.394	60	24	19	33	14.954	51	18	19	36
13.731	51	20	21	39	14.400	48	20	27	45	14.966	55	21	24	42
13.737	51	27	24	33	14.405	55	20	22	42	14.973	42	17	20	33
13.750	33	42	..	24	14.412	42	17	21	36	15.000	45	36	..	30
13.756	48	17	19	39	14.423	45	24	30	39	15.038	60	19	20	42
13.765	39	17	27	45	14.429	55	18	17	36	15.043	48	27	33	39
13.776	45	21	27	42	14.436	48	19	24	42	15.053	39	19	33	45
13.788	42	36	39	33	14.444	39	36	..	27	15.059	48	17	24	45
13.804	48	17	22	45	14.453	51	19	21	39	15.072	45	19	21	33
13.816	42	19	30	48	14.464	45	20	27	42	15.079	60	21	19	36
13.823	55	21	19	36	14.474	55	19	24	48	15.098	55	17	21	45
13.841	60	17	20	51	14.480	48	17	20	39	15.105	48	22	27	39
13.846	48	24	27	39	14.489	51	22	30	48	15.111	51	30	24	27
13.853	48	21	20	33	14.504	39	22	27	33	15.126	45	21	36	51
13.866	45	21	33	51	14.514	55	20	19	36	15.152	45	33	30	27
13.878	51	21	24	42	14.530	51	27	30	39	15.158	48	19	27	45
13.884	42	22	24	33	14.538	42	20	27	39	15.167	42	36	39	30
13.889	45	27	30	36	14.545	48	36	..	33	15.179	51	24	30	42
13.897	42	17	27	48	14.550	55	27	30	42	15.195	39	22	36	42
13.904	39	17	20	33	14.559	36	17	33	48	15.204	42	17	24	39
13.909	51	30	27	33	14.571	51	21	27	45	15.225	55	17	24	51
13.919	60	21	19	39	14.583	42	36	30	24	15.231	36	20	33	39

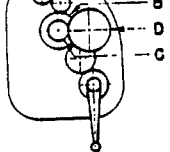
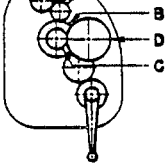

TABLE OF LEADS (15.241 to 17.550)

Lead of Spiral in Inches	Lead of Spiral in Inches				Lead of Spiral in Inches	Lead of Spiral in Inches				Lead of Spiral in Inches	Lead of Spiral in Inches			
	A	B	C	D		A	B	C	D		A	B	C	D
15.241	45	17	19	33	15.968	60	17	19	42	16.783	48	22	30	39
15.256	51	18	21	39	15.983	51	27	33	39	16.794	39	19	27	33
15.273	42	33	36	30	16.000	48	36	..	30	16.800	42	20	36	45
15.278	55	24	24	36	16.032	36	19	33	39	16.806	55	30	33	36
15.294	42	21	39	51	16.042	42	36	33	24	16.813	51	21	27	39
15.300	51	20	27	45	16.049	51	22	27	39	16.824	39	17	33	45
15.306	45	21	30	42	16.071	45	24	36	42	16.837	45	21	33	42
15.311	48	19	20	33	16.082	55	19	20	36	16.845	45	22	42	51
15.321	39	20	33	42	16.106	51	19	27	45	16.852	42	36	39	27
15.338	51	19	24	42	16.117	55	21	24	39	16.859	51	22	24	33
15.354	48	18	19	33	16.127	55	18	19	36	16.875	45	24	27	30
15.385	45	39	36	27	16.134	48	21	36	51	16.888	55	19	21	36
15.395	39	19	36	48	16.150	51	20	19	30	16.904	42	19	39	51
15.400	42	20	33	45	16.162	48	33	30	27	16.917	45	19	30	42
15.407	39	27	48	45	16.176	55	17	24	48	16.923	55	20	24	39
15.429	36	21	27	30	16.190	51	21	30	45	16.947	55	17	22	42
15.439	55	19	24	45	16.200	36	20	27	30	16.970	42	33	36	27
15.441	42	17	30	48	16.211	42	19	33	45	16.985	42	17	33	48
15.455	51	36	..	33	16.239	60	18	19	39	17.000	51	36	..	30
15.469	45	20	33	48	16.250	39	36	..	24	17.017	45	17	27	42
15.476	45	27	39	42	16.257	48	17	19	33	17.028	55	19	30	51
15.502	36	19	27	33	16.283	55	19	27	48	17.045	45	33	30	24
15.513	55	20	22	39	16.290	36	17	30	39	17.053	36	19	27	30
15.529	36	17	33	45	16.296	48	27	33	36	17.063	42	20	39	48
15.547	48	19	24	39	16.313	51	18	19	33	17.075	55	17	19	36
15.556	42	36	..	27	16.327	48	21	30	42	17.081	51	19	21	33
15.571	45	17	30	51	16.333	42	18	21	30	17.094	60	27	30	39
15.577	45	20	27	39	16.346	51	24	30	39	17.105	39	19	30	36
15.587	55	19	21	39	16.364	36	39	..	22	17.112	48	17	20	33
15.600	39	20	36	45	16.370	39	27	51	45	17.128	45	17	33	51
15.612	51	21	27	42	16.387	45	21	39	51	17.143	36	39	..	21
15.620	42	22	27	33	16.397	45	19	27	39	17.172	51	33	30	27
15.625	45	36	30	24	16.404	51	19	22	36	17.182	42	22	27	30
15.632	33	19	27	30	16.410	48	27	36	39	17.195	60	17	19	39
15.642	45	22	39	51	16.421	39	19	36	45	17.206	39	17	36	48
15.658	51	19	21	36	16.450	60	21	19	33	17.225	36	19	30	33
15.670	55	27	30	39	16.471	42	17	30	45	17.236	55	27	33	39
15.686	48	18	30	51	16.484	45	21	30	39	17.255	55	17	24	45
15.692	51	20	24	39	16.500	33	36	..	20	17.273	51	17	19	33
15.714	48	24	33	42	16.508	48	27	39	42	17.308	45	24	36	39
15.724	33	39	..	21	16.518	51	19	24	39	17.316	60	21	20	33
15.734	45	22	30	39	16.529	60	22	20	33	17.326	36	17	27	33
15.741	51	27	30	36	16.544	45	17	30	48	17.333	48	36	39	30
15.750	42	24	27	30	16.558	51	22	30	42	17.347	51	21	30	42
15.762	55	17	19	39	16.579	42	19	36	48	17.355	42	33	30	22
15.772	39	17	33	48	16.593	42	27	48	45	17.368	33	39	..	19
15.789	30	42	..	19	16.609	48	17	30	51	17.376	48	17	24	39
15.817	55	17	22	45	16.615	48	20	27	39	17.386	51	24	27	33
15.824	48	21	27	39	16.623	48	21	24	33	17.411	45	24	39	42
15.833	51	17	19	36	16.639	36	17	33	42	17.421	55	17	21	39
15.865	45	24	33	39	16.667	45	36	..	27	17.439	42	17	36	51
15.873	55	21	20	33	16.684	48	22	39	51	17.455	48	33	36	30
15.882	27	42	..	17	16.696	51	24	33	42	17.471	33	17	27	30
15.889	39	30	33	27	16.714	39	20	36	42	17.479	48	21	39	51
15.909	42	33	30	24	16.725	39	19	22	27	17.490	48	19	27	39
15.918	39	21	36	42	16.736	45	22	27	33	17.500	42	39	..	24
15.928	48	17	22	39	16.762	48	21	33	45	17.531	51	20	33	48
15.938	51	20	30	48	16.776	51	19	30	48	17.540	39	27	51	42
15.955	39	22	27	30						17.550	39	20	27	30



CINCINNATI DIAL TYPE MILLING MACHINES

TABLE OF LEADS (17.582 to 20.588)

Lead of Spiral in Inches					Lead of Spiral in Inches					Lead of Spiral in Inches				
	A	B	C	D		A	B	C	D		A	B	C	D
17.582	48	21	30	39	18.519	60	27	30	36	19.479	51	24	33	36
17.593	60	18	19	36	18.529	42	17	36	48	19.500	39	36	..	20
17.600	48	20	33	45	18.545	51	30	36	33	19.522	51	19	24	33
17.622	42	39	36	22	18.571	39	36	..	21	19.548	48	17	27	39
17.630	42	27	51	45	18.583	51	19	27	39	19.556	48	30	33	27
17.647	30	39	..	17	18.595	45	22	30	33	19.592	48	21	36	42
17.654	51	20	27	39	18.609	45	19	33	42	19.608	60	17	20	36
17.662	51	21	24	33	18.627	60	17	19	36	19.615	51	24	36	39
17.679	45	20	33	42	18.660	39	19	30	33	19.636	48	22	27	30
17.690	55	19	22	36	18.673	55	27	33	36	19.643	33	21	30	24
17.708	51	24	30	36	18.685	45	17	36	51	19.664	39	17	36	42
17.727	39	36	..	22	18.700	51	20	33	45	19.684	51	19	33	45
17.763	45	19	36	48	18.707	55	21	30	42	19.697	45	33	39	27
17.778	48	33	..	27	18.731	55	19	33	51	19.732	51	24	39	42
17.810	51	21	33	45	18.750	45	36	..	24	19.744	42	18	33	39
17.824	55	18	21	36	18.770	39	17	27	33	19.765	42	17	36	45
17.832	51	22	30	39	18.803	55	18	24	39	19.780	45	21	36	39
17.843	42	18	39	51	18.816	39	19	33	36	19.800	36	30	33	20
17.851	48	22	27	33	18.824	48	18	36	51	19.810	48	21	39	45
17.857	60	24	30	42	18.857	48	20	33	42	19.835	48	22	30	33
17.875	39	30	33	24	18.873	55	17	21	36	19.850	48	19	33	42
17.898	45	22	42	48	18.881	45	22	36	39	19.861	39	27	33	24
17.919	36	17	33	39	18.889	51	33	..	27	19.870	51	22	36	42
17.949	45	39	42	27	18.900	42	20	27	30	19.895	42	19	27	30
17.959	48	21	33	42	18.909	48	33	39	30	19.910	55	17	24	39
17.968	42	17	24	33	18.947	36	39	..	19	19.922	45	24	51	48
17.981	51	24	33	39	18.958	42	36	39	24	19.931	48	17	36	51
18.000	36	39	..	20	18.967	51	22	27	33	20.000	48	36	..	24
18.006	55	24	33	42	18.994	45	22	39	42	20.040	45	19	33	39
18.025	39	17	33	42	19.031	55	17	30	51	20.074	42	17	39	48
18.030	51	18	21	33	19.038	45	20	33	39	20.096	42	19	30	33
18.045	48	19	30	42	19.048	55	21	24	33	20.132	51	19	36	48
18.056	45	36	39	27	19.059	36	17	27	30	20.147	55	21	30	39
18.086	42	19	27	33	19.082	51	21	33	42	20.167	55	20	22	30
18.092	55	19	30	48	19.091	42	36	..	22	20.192	45	39	42	24
18.100	60	17	20	39	19.097	55	24	30	36	20.202	60	27	30	33
18.111	45	19	39	51	19.118	45	18	39	51	20.211	48	19	24	30
18.118	42	17	33	45	19.125	51	24	27	30	20.222	42	30	39	27
18.132	45	21	33	39	19.139	60	19	20	33	20.238	51	21	30	36
18.151	48	17	27	42	19.145	48	39	42	27	20.250	45	20	27	30
18.182	48	33	30	24	19.158	42	19	39	45	20.260	39	33	36	21
18.200	42	20	39	45	19.173	51	19	30	42	20.301	45	19	36	42
18.219	45	19	30	39	19.192	60	18	19	33	20.321	60	17	19	33
18.250	55	17	22	39	19.206	55	21	33	45	20.342	42	27	51	39
18.270	48	17	33	51	19.231	55	22	30	39	20.362	45	17	30	39
18.286	48	21	36	45	19.243	45	19	39	48	20.370	55	33	..	27
18.308	42	30	51	39	19.250	42	30	33	24	20.392	48	18	39	51
18.326	45	17	27	39	19.259	48	36	39	27	20.400	51	20	24	30
18.333	55	33	..	30	19.286	45	21	27	30	20.408	60	21	30	42
18.353	39	17	36	45	19.298	55	19	30	45	20.433	55	19	36	51
18.367	45	21	36	42	19.319	48	19	39	51	20.455	45	36	..	22
18.373	48	19	24	33	19.341	48	21	33	39	20.463	51	36	39	27
18.384	42	33	39	27	19.378	45	19	27	33	20.513	45	27	48	39
18.409	45	22	27	30	19.385	42	20	36	39	20.526	39	36	..	19
18.421	55	19	21	33	19.394	48	33	36	27	20.535	48	17	24	33
18.454	51	19	33	48	19.412	33	36	..	17	20.549	51	21	33	39
18.462	48	24	36	39	19.429	51	21	36	45	20.571	48	21	27	30
18.474	39	19	27	30	19.433	48	19	30	39	20.578	55	21	33	42
18.487	55	17	24	42	19.444	45	36	42	27	20.588	55	17	21	33

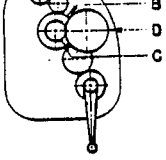

TABLE OF LEADS (20.606 to 24.740)

Lead of Spiral in Inches	A B C D				Lead of Spiral in Inches	A B C D				Lead of Spiral in Inches	A B C D			
	A	B	C	D		A	B	C	D		A	B	C	D
20.606	51	33	36	27	21.857	51	21	27	30	23.214	45	36	39	21
20.625	45	30	33	24	21.862	45	19	36	39	23.253	48	17	42	51
20.635	39	21	30	27	21.875	45	36	42	24	23.269	55	20	33	39
20.648	51	19	30	39	21.895	48	19	39	45	23.294	36	17	33	30
20.670	48	19	27	33	21.962	51	19	27	33	23.320	48	19	36	39
20.682	42	33	39	24	21.978	60	21	30	39	23.333	42	36	..	18
20.706	48	17	33	45	22.000	48	30	33	24	23.375	51	30	33	24
20.719	51	20	39	48	22.028	45	39	42	22	23.400	39	30	36	20
20.741	48	36	42	27	22.037	42	27	51	36	23.437	45	24	30	24
20.769	45	20	36	39	22.058	45	17	30	36	23.459	48	19	39	42
20.778	51	30	33	27	22.068	39	36	55	27	23.487	51	19	42	48
20.798	45	17	33	42	22.078	51	21	30	33	23.504	55	18	30	39
20.805	48	19	42	51	22.105	42	36	..	19	23.529	55	17	24	33
20.816	51	21	36	42	22.154	48	20	36	39	23.538	51	20	36	39
20.826	42	33	36	22	22.186	48	17	33	42	23.579	48	19	42	45
20.833	45	27	30	24	22.222	48	36	45	27	23.611	51	27	30	24
20.842	36	30	33	19	22.235	42	17	27	30	23.636	48	33	39	24
20.856	39	17	30	33	22.243	55	17	33	48	23.684	45	33	..	19
20.864	51	22	27	30	22.262	51	21	33	36	23.725	55	17	22	30
20.905	42	17	33	39	22.286	39	30	36	21	23.765	42	27	55	36
20.934	55	17	33	51	22.313	51	20	42	48	23.800	51	20	42	45
20.952	48	21	33	36	22.323	51	33	39	27	23.810	45	21	30	27
20.979	60	22	30	39	22.344	39	24	33	24	23.824	45	17	27	30
21.000	42	39	..	20	22.368	51	19	30	36	23.833	39	27	33	20
21.010	48	33	39	27	22.392	39	33	36	19	23.864	45	33	42	24
21.029	39	17	33	36	22.400	48	20	42	45	23.891	48	17	33	39
21.053	55	19	24	33	22.418	51	21	36	39	23.947	42	19	39	36
21.074	51	22	30	33	22.449	55	21	36	42	23.974	51	18	33	39
21.099	48	21	36	39	22.460	42	17	30	33	24.000	48	33	..	20
21.154	55	20	30	39	22.500	45	36	..	20	24.040	51	33	42	27
21.176	36	39	..	17	22.551	51	21	39	42	24.063	42	24	33	24
21.212	45	33	42	27	22.564	48	18	33	39	24.074	55	27	39	33
21.228	55	19	22	30	22.579	39	30	33	19	24.115	42	33	36	19
21.250	51	33	..	24	22.588	48	17	36	45	24.123	55	19	30	36
21.273	39	30	36	22	22.626	42	27	48	33	24.158	51	19	27	30
21.316	45	19	27	30	22.667	51	30	36	27	24.176	55	21	36	39
21.333	48	30	36	27	22.689	45	17	36	42	24.202	48	17	36	42
21.377	48	19	33	39	22.698	39	27	33	21	24.231	45	20	42	39
21.389	42	27	33	24	22.713	51	19	33	39	24.242	48	33	45	27
21.399	51	22	36	39	22.727	45	27	30	22	24.265	55	17	36	48
21.412	42	17	39	45	22.737	48	19	27	30	24.286	51	33	..	21
21.429	45	36	..	21	22.744	55	19	33	42	24.292	60	19	30	39
21.450	39	30	33	20	22.750	42	30	39	24	24.316	42	30	33	19
21.474	51	19	36	45	22.768	51	21	45	48	24.375	45	30	39	24
21.507	45	17	39	48	22.805	42	17	36	39	24.402	51	19	30	33
21.526	51	22	39	42	22.837	55	17	36	51	24.434	45	17	36	39
21.538	48	24	42	39	22.857	48	33	..	21	24.444	55	30	36	27
21.577	51	20	33	39	22.885	51	24	42	39	24.471	48	17	39	45
21.592	48	17	39	51	22.909	42	30	36	22	24.494	55	19	33	39
21.607	55	20	33	42	22.917	55	30	..	24	24.519	45	24	51	39
21.636	51	33	42	30	22.941	39	36	..	17	24.545	45	30	36	22
21.654	48	19	36	42	22.967	48	19	30	33	24.561	42	19	30	27
21.687	39	36	..	18	23.008	51	19	36	42	24.580	45	17	39	42
21.711	55	19	36	48	23.021	51	24	39	36	24.605	51	19	33	36
21.719	48	17	30	39	23.077	48	24	45	39	24.615	48	21	42	39
21.795	51	18	30	39	23.100	42	30	33	20	24.632	39	30	36	19
21.809	51	19	39	48	23.111	48	30	39	27	24.706	42	36	..	17
21.818	48	33	..	22	23.158	55	19	24	30	24.727	48	22	51	45
21.825	55	21	30	36	23.182	51	33	..	22	24.740	55	17	39	51

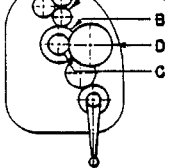

TABLE OF LEADS (24.750 to 30.390)

Lead of Spiral in Inches	Lead of Spiral in Inches				Lead of Spiral in Inches	Lead of Spiral in Inches				Lead of Spiral in Inches	Lead of Spiral in Inches			
	A	B	C	D		A	B	C	D		A	B	C	D
24.750	45	30	33	20	26.353	48	17	42	45	28.373	55	21	39	36
24.782	39	27	36	21	26.374	48	21	45	39	28.421	45	30	36	19
24.777	51	19	36	39	26.400	48	30	33	20	28.437	42	24	39	24
24.793	60	22	30	33	26.442	45	24	55	39	28.507	45	17	42	39
24.826	55	24	39	36	26.471	45	36	..	17	28.519	55	27	42	30
24.887	55	17	30	39	26.494	51	33	36	21	28.547	55	17	45	51
24.914	48	17	45	51	26.526	42	30	36	19	28.571	48	21	30	24
24.925	51	19	39	42	26.535	55	19	33	36	28.636	45	30	42	22
24.935	48	33	36	21	26.591	45	30	39	22	28.676	45	36	39	17
24.965	51	22	42	39	26.644	55	17	42	51	28.701	51	33	39	21
25.000	51	17	30	36	26.667	48	36	..	18	28.718	48	18	42	39
25.027	39	33	36	17	26.714	51	30	33	21	28.737	42	30	39	19
25.053	51	19	42	45	26.748	51	22	45	39	28.759	51	19	45	42
25.088	39	27	33	19	26.765	42	36	39	17	28.810	55	30	33	21
25.114	51	33	39	24	26.786	45	21	30	24	28.875	42	24	33	20
25.143	48	30	33	21	26.812	39	24	33	20	28.889	48	27	39	24
25.175	48	22	45	39	26.842	51	33	..	19	28.907	51	19	42	39
25.200	42	30	36	20	26.880	55	19	39	42	28.947	45	27	33	19
25.210	60	17	30	42	26.952	42	33	36	17	28.977	51	24	45	33
25.235	39	17	33	30	26.984	51	21	30	27	29.079	51	19	39	36
25.263	48	33	..	19	27.000	45	30	36	20	29.091	48	33	42	21
25.278	42	27	39	24	27.018	42	27	33	19	29.101	55	21	30	27
25.289	51	33	36	22	27.045	51	33	42	24	29.118	45	17	33	30
25.325	45	33	39	21	27.068	48	19	45	42	29.143	51	30	36	21
25.385	60	20	33	39	27.083	55	24	39	33	29.167	45	27	42	24
25.397	48	21	30	27	27.149	60	17	30	39	29.198	42	33	39	17
25.412	48	17	27	30	27.176	42	17	33	30	29.221	45	21	30	22
25.420	55	17	33	42	27.206	48	19	42	39	29.250	45	30	39	20
25.455	48	33	42	24	27.273	48	33	45	24	29.282	51	33	36	19
25.463	55	27	30	24	27.300	42	30	39	20	29.333	48	27	33	20
25.490	39	17	30	27	27.368	39	27	36	19	29.412	60	17	30	36
25.500	51	33	..	20	27.397	51	33	39	22	29.423	51	20	45	39
25.536	39	24	33	21	27.429	48	30	36	21	29.474	42	27	36	19
25.568	45	24	30	22	27.462	51	20	42	39	29.504	51	22	42	33
25.641	60	18	30	39	27.500	55	33	..	20	29.526	51	30	33	19
25.658	45	36	39	19	27.529	39	30	36	17	29.545	45	27	39	22
25.668	48	17	30	33	27.560	48	33	36	19	29.605	45	19	30	24
25.714	45	30	36	21	27.576	42	27	39	22	29.630	48	18	30	27
25.758	51	27	30	22	27.632	45	19	42	36	29.657	55	17	33	36
25.785	48	33	39	22	27.692	48	20	45	39	29.683	51	27	33	21
25.837	45	33	36	19	27.731	55	17	36	42	29.714	48	30	39	21
25.846	48	20	42	39	27.755	51	21	48	42	29.750	51	30	42	24
25.855	55	18	33	39	27.769	48	33	42	22	29.774	36	21	33	19
25.882	55	17	36	45	27.789	48	30	33	19	29.792	55	30	39	24
25.905	51	21	48	45	27.818	51	30	36	22	29.825	51	19	30	27
25.926	42	18	30	27	27.857	45	30	39	21	29.864	55	17	36	39
25.972	51	27	33	24	27.937	48	27	33	21	29.890	51	21	48	39
26.000	48	30	39	24	27.990	45	33	39	19	30.000	55	30	36	22
26.020	51	21	45	42	28.009	55	27	33	24	30.042	55	17	39	42
26.033	45	33	42	22	28.022	51	21	45	39	30.136	51	30	39	22
26.053	45	30	33	19	28.039	55	17	39	45	30.144	45	33	42	19
26.063	48	17	36	39	28.050	51	30	33	20	30.196	42	17	33	27
26.124	42	33	39	19	28.070	48	19	30	27	30.222	51	30	48	27
26.154	51	21	42	39	28.125	45	24	36	24	30.252	48	17	45	42
26.182	48	30	36	22	28.224	39	24	33	19	30.303	60	22	30	27
26.218	48	17	39	42	28.235	48	36	..	17	30.316	48	30	36	19
26.250	45	30	42	24	28.283	60	27	42	33	30.333	42	27	39	20
26.287	55	17	39	48	28.309	55	17	42	48	30.357	51	21	30	24
26.310	51	21	39	36	28.333	51	27	33	22	30.390	39	22	36	21

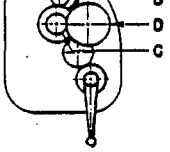
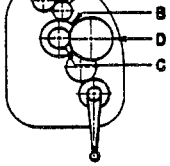

TABLE OF LEADS (30.407 to 37.227)

Lead of Spiral in Inches	Lead of Spiral in Inches				Lead of Spiral in Inches	Lead of Spiral in Inches				Lead of Spiral in Inches	Lead of Spiral in Inches			
	A	B	C	D		A	B	C	D		A	B	C	D
30.407	48	17	42	39	32.568	45	24	33	19	34.895	51	30	39	19
30.450	55	17	48	51	32.579	48	17	45	39	34.921	55	27	36	21
30.476	48	27	36	21	32.592	51	18	45	39	35.000	48	24	42	24
30.513	51	18	42	39	32.727	51	33	36	17	35.049	55	17	39	36
30.545	48	30	42	22	32.738	55	21	30	24	35.065	45	22	36	21
30.558	55	24	36	27	32.807	51	27	33	19	35.079	51	27	39	21
30.588	39	17	36	27	32.842	48	30	39	19	35.088	60	19	30	27
30.600	51	30	36	20	32.906	55	18	42	39	35.188	39	21	36	19
30.643	39	20	33	21	32.941	42	27	36	17	35.256	55	18	45	39
30.677	51	19	48	42	33.000	48	24	33	20	35.294	45	27	36	17
30.694	51	27	39	24	33.016	48	27	39	21	35.325	51	21	48	33
30.769	48	18	45	39	33.036	51	19	48	39	35.357	45	21	33	20
30.789	45	30	39	19	33.056	51	27	42	24	35.368	48	30	42	19
30.802	48	33	36	17	33.088	45	17	30	24	35.380	55	27	33	19
30.882	45	36	42	17	33.117	51	21	30	22	35.417	51	27	45	24
30.909	51	27	36	22	33.158	45	30	42	19	35.455	42	22	39	21
30.937	45	24	33	20	33.239	45	24	39	22	35.526	45	24	36	19
30.952	45	27	39	21	33.277	36	17	33	21	35.556	48	27	42	21
30.972	51	19	45	39	33.333	55	27	36	22	35.588	55	17	33	30
31.023	42	24	39	22	33.369	48	33	39	17	35.648	55	27	42	24
31.059	48	17	33	30	33.393	51	24	33	21	35.686	42	27	39	17
31.111	48	27	42	24	33.429	39	21	36	20	35.700	51	30	42	20
31.167	51	27	33	20	33.485	51	27	39	22	35.714	60	21	30	24
31.200	48	30	39	20	33.553	51	19	30	24	35.750	55	20	39	30
31.250	60	24	30	24	33.589	39	22	36	19	35.795	45	24	42	22
31.283	45	33	39	17	33.611	55	27	33	20	35.921	42	24	30	19
31.316	51	19	42	36	33.684	48	27	36	19	35.936	48	17	42	33
31.360	55	19	39	36	33.704	42	27	39	18	35.948	55	17	30	27
31.385	51	20	48	39	33.719	51	22	48	33	35.962	51	20	55	39
31.429	55	30	36	21	33.750	45	24	36	20	36.000	51	30	36	17
31.481	51	18	30	27	33.772	55	19	42	36	36.012	55	24	33	21
31.500	45	30	42	20	33.846	48	20	55	39	36.050	39	17	33	21
31.515	48	27	39	22	33.868	39	19	33	20	36.061	51	27	42	22
31.544	39	17	33	24	33.882	48	30	36	17	36.096	45	17	30	22
31.571	51	30	39	21	33.939	48	27	42	22	36.111	55	27	39	22
31.612	51	22	45	33	33.951	55	18	30	27	36.172	42	22	36	19
31.722	51	33	39	19	33.971	42	17	33	24	36.184	55	19	45	36
31.746	60	21	30	27	34.000	51	30	48	24	36.364	48	27	45	22
31.765	45	30	36	17	34.048	55	30	39	21	36.397	45	17	33	24
31.818	45	27	42	22	34.091	55	22	45	33	36.429	51	30	45	21
31.842	55	30	33	19	34.125	42	24	39	20	36.474	42	19	33	20
31.875	51	30	45	24	34.163	51	19	42	33	36.491	48	27	39	19
31.909	39	22	36	20	34.211	45	27	39	19	36.582	45	24	39	20
31.930	42	27	39	19	34.249	51	21	55	39	36.603	51	19	45	33
32.000	48	21	42	30	34.286	48	24	36	21	36.667	55	27	36	20
32.011	55	27	33	21	34.375	55	30	45	24	36.706	48	30	39	17
32.083	42	18	33	24	34.412	45	30	39	17	36.818	45	22	36	20
32.118	42	30	39	17	34.450	48	19	30	22	36.842	55	19	42	33
32.143	45	24	36	21	34.510	48	17	33	27	36.908	51	24	33	19
32.164	55	19	30	27	34.531	51	24	39	24	36.923	51	17	48	39
32.211	51	30	36	19	34.615	51	17	45	39	36.947	39	20	36	19
32.231	60	22	39	33	34.630	51	18	33	27	36.975	55	17	48	42
32.256	39	19	33	21	34.667	48	27	39	20	37.037	60	18	30	27
32.297	45	19	30	22	34.711	60	22	42	33	37.059	45	30	42	17
32.308	51	17	42	39	34.737	48	19	33	24	37.091	51	22	48	30
32.353	45	17	33	27	34.773	51	30	45	22	37.143	48	24	39	21
32.381	51	27	36	21	34.821	45	24	39	21	37.187	51	24	42	24
32.465	51	30	42	22	34.842	55	17	42	39	37.218	45	21	33	19
32.500	48	24	39	24	34.872	51	18	48	39	37.227	42	22	39	20



CINCINNATI DIAL TYPE MILLING MACHINES

TABLE OF LEADS (37.240 to 46.324)

Lead of Spiral in Inches	Lead of Spiral in Inches				Lead of Spiral in Inches	Lead of Spiral in Inches				Lead of Spiral in Inches	Lead of Spiral in Inches			
	A	B	C	D		A	B	C	D		A	B	C	D
37.240	55	24	39	24	40.000	51	27	36	17	43.105	42	20	39	19
37.321	60	19	39	33	40.071	51	21	33	20	43.137	55	27	36	17
37.348	55	18	33	27	40.104	55	24	42	24	43.175	51	27	48	21
37.403	48	22	36	21	40.147	42	24	39	17	43.214	55	21	33	20
37.500	55	24	36	22	40.191	60	19	42	33	43.308	48	21	36	19
37.540	39	17	36	22	40.263	51	24	36	19	43.333	51	27	39	17
37.579	51	30	42	19	40.428	42	22	36	17	43.421	55	19	36	24
37.632	55	19	39	30	40.441	55	17	45	36	43.468	51	24	45	22
37.647	48	27	36	17	40.476	51	27	45	21	43.618	51	24	39	19
37.670	51	24	39	22	40.519	48	22	39	21	43.636	48	22	42	21
37.714	48	21	33	20	40.568	51	24	42	22	43.651	55	21	45	27
37.745	55	17	42	36	40.602	45	21	36	19	43.676	45	17	33	20
37.778	51	27	48	24	40.625	60	24	39	24	43.714	51	21	36	20
37.812	55	24	33	20	40.741	55	27	42	21	43.750	60	24	42	24
37.831	55	27	39	21	40.765	42	17	33	20	43.797	42	22	39	17
37.853	39	17	33	20	40.784	48	27	39	17	43.923	51	22	36	19
37.895	48	30	45	19	40.800	51	20	48	30	43.985	45	21	39	19
37.917	42	24	39	18	40.909	60	20	30	22	44.000	48	18	33	20
37.987	45	22	39	21	40.926	51	27	39	18	44.074	51	27	42	18
38.182	48	24	42	22	41.053	48	24	39	19	44.118	60	17	30	24
38.194	55	27	45	24	41.143	48	21	36	20	44.136	55	18	39	27
38.235	45	27	39	17	41.176	45	27	42	17	44.211	48	24	42	19
38.250	51	24	36	20	41.212	51	27	48	22	44.289	51	20	33	19
38.487	45	24	39	19	41.250	55	24	36	20	44.318	60	24	39	22
38.500	55	20	42	30	41.270	60	21	39	27	44.370	48	17	33	21
38.519	48	27	39	18	41.294	39	17	36	20	44.444	48	27	45	18
38.571	45	21	36	20	41.340	48	22	36	19	44.471	42	20	36	17
38.596	55	27	36	19	41.364	42	22	39	18	44.485	55	17	33	24
38.636	51	27	45	22	41.437	51	24	39	20	44.524	51	18	33	21
38.756	45	22	36	19	41.481	48	27	42	18	44.571	48	21	39	20
38.772	51	27	39	19	41.597	45	17	33	21	44.625	51	24	42	20
38.824	48	17	33	24	41.667	55	27	45	22	44.687	55	24	39	20
38.857	51	30	48	21	41.684	48	19	33	20	44.737	51	27	45	19
38.889	60	24	42	27	41.711	60	17	39	33	44.785	48	22	39	19
38.958	51	18	33	24	41.727	51	22	36	20	44.920	60	17	42	33
39.000	51	30	39	17	41.754	51	27	42	19	45.000	55	22	36	20
39.043	51	19	48	33	41.786	45	21	39	20	45.029	55	19	42	27
39.079	45	20	33	19	41.813	55	27	39	19	45.205	51	22	39	20
39.187	42	22	39	19	41.905	48	18	33	21	45.215	45	22	42	19
39.216	60	17	30	27	41.986	45	22	39	19	45.294	55	17	42	30
39.273	48	22	36	20	42.000	48	24	42	20	45.333	51	27	48	20
39.296	55	22	33	21	42.014	55	18	33	24	45.378	45	21	36	17
39.298	48	27	42	19	42.059	55	17	39	30	45.455	60	22	45	27
39.328	39	17	36	21	42.105	48	27	45	19	45.474	48	20	36	19
39.375	45	24	42	20	42.180	51	21	33	19	45.489	55	21	33	19
39.394	60	22	39	27	42.308	55	17	51	39	45.500	42	20	39	18
39.464	51	24	39	21	42.353	48	30	45	17	45.536	51	24	45	21
39.474	55	19	45	33	42.424	60	22	42	27	45.614	60	19	39	27
39.529	48	30	42	17	42.500	51	27	45	20	45.714	48	21	36	18
39.542	55	17	33	27	42.545	48	22	39	20	45.818	48	22	42	20
39.667	51	27	42	20	42.560	55	24	39	21	45.833	55	24	48	24
39.699	48	21	33	19	42.632	45	20	36	19	45.882	48	24	39	17
39.722	55	27	39	20	42.778	55	27	42	20	45.975	45	17	33	19
39.740	51	22	36	21	42.910	42	17	33	19	46.015	51	21	36	19
39.789	42	20	36	19	42.947	51	19	48	30	46.042	51	24	39	18
39.803	55	24	33	19	42.969	55	24	45	24	46.184	45	20	39	19
39.819	55	17	48	39	43.015	45	24	39	17	46.203	48	22	36	17
39.845	39	17	33	19	43.052	51	22	39	21	46.316	48	18	33	19
39.886	45	22	39	20	43.082	60	19	30	22	46.324	45	24	42	17

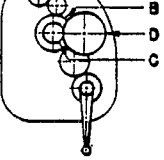
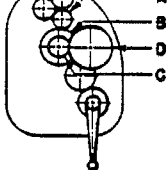

TABLE OF LEADS (46.364 to 60.662)

Lead of Spiral in Inches					Lead of Spiral in Inches					Lead of Spiral in Inches				
	A	B	C	D		A	B	C	D		A	B	C	D
46.364	51	24	48	22	50.155	45	19	36	17	54.643	51	21	45	20
46.429	60	24	39	21	50.227	51	22	39	18	54.678	55	19	51	27
46.561	55	21	48	27	50.329	51	24	45	19	54.737	48	19	39	18
46.588	48	17	33	20	50.370	51	27	48	18	54.902	60	17	42	27
46.667	51	27	42	17	50.417	55	18	33	20	55.000	55	24	48	20
46.732	55	27	39	17	50.478	48	21	42	19	55.059	48	20	39	17
46.753	48	21	45	22	50.649	60	22	39	21	55.250	51	20	39	18
46.811	42	17	36	19	50.712	42	19	39	17	55.263	55	22	42	19
46.875	60	24	45	24	50.794	60	21	48	27	55.462	55	21	36	17
46.925	45	22	30	17	50.824	48	20	36	17	55.556	60	18	45	27
46.974	51	24	42	19	50.840	55	17	33	21	55.588	45	20	42	17
47.039	55	24	39	19	50.909	48	22	42	18	55.636	51	22	48	20
47.059	48	27	45	17	50.926	55	18	45	27	55.655	55	24	51	21
47.143	55	21	36	20	50.980	60	17	39	27	55.714	60	21	39	20
47.222	51	27	45	18	51.000	51	24	48	20	55.981	60	22	39	19
47.273	48	22	39	18	51.071	55	21	39	20	56.000	48	20	42	18
47.357	51	21	39	20	51.136	60	22	45	24	56.140	60	19	48	27
47.531	55	18	42	27	51.244	51	19	42	22	56.192	55	17	33	19
47.584	51	22	39	19	51.318	55	22	39	19	56.250	55	22	45	20
47.619	60	21	45	27	51.429	48	21	45	20	56.368	51	20	42	19
47.647	45	20	36	17	51.462	55	19	48	27	56.447	55	20	39	19
47.719	51	27	48	19	51.562	55	24	45	20	56.471	48	21	42	17
47.763	55	20	33	10	51.618	45	20	39	17	56.618	55	24	42	17
47.812	51	24	45	20	51.675	48	22	45	19	56.667	51	24	48	18
47.895	42	19	39	18	51.852	60	18	42	27	56.746	55	21	39	18
48.000	48	21	42	20	51.944	55	20	51	27	56.842	51	19	36	17
48.016	55	18	33	21	52.000	48	20	39	18	57.143	55	22	48	21
48.125	55	24	42	20	52.105	55	20	36	19	57.273	60	22	42	20
48.148	60	18	39	27	52.159	51	22	45	20	57.292	55	24	45	18
48.176	42	20	39	17	52.342	51	20	39	19	57.353	55	22	39	17
48.230	48	22	42	19	52.381	55	24	48	21	57.519	51	21	45	19
48.246	55	19	45	27	52.437	48	21	39	17	57.716	55	18	51	27
48.316	51	20	36	19	52.500	55	22	42	20	57.754	48	22	45	17
48.403	48	21	36	17	52.574	55	24	39	17	57.895	55	24	48	19
48.485	60	22	48	27	52.632	60	19	45	27	57.957	48	19	39	17
48.529	55	24	36	17	52.941	48	24	45	17	58.158	51	19	39	18
48.571	51	24	48	21	52.987	51	22	48	21	58.235	55	20	36	17
48.698	55	24	51	24	53.053	48	20	42	19	58.286	51	21	48	20
48.750	55	22	39	20	53.070	55	18	33	19	58.333	55	22	42	18
48.889	55	20	48	27	53.125	55	24	51	22	58.437	55	24	51	20
49.040	48	17	33	19	53.182	60	22	39	20	58.500	51	20	39	17
49.091	51	22	36	17	53.333	51	27	48	17	58.514	45	19	42	17
49.107	55	24	45	21	53.382	55	17	33	20	58.565	51	22	48	19
49.123	60	19	42	27	53.472	55	24	42	18	58.647	60	21	39	19
49.160	45	21	39	17	53.498	48	19	36	17	58.824	60	17	45	27
49.211	55	19	51	30	53.529	42	18	39	17	58.929	55	21	45	20
49.263	48	20	39	19	53.571	55	22	45	21	58.947	48	19	42	18
49.412	60	17	42	30	53.684	51	24	48	19	59.091	60	22	39	18
49.471	55	21	51	27	53.759	55	21	39	19	59.211	55	22	45	19
49.500	51	17	33	20	53.904	48	22	42	17	59.259	60	18	48	27
49.524	48	21	39	18	53.922	55	17	45	27	59.294	48	20	42	17
49.583	51	24	42	18	54.000	51	20	36	17	59.500	51	20	42	18
49.624	55	21	36	19	54.091	51	22	42	18	59.583	55	20	39	18
49.653	55	24	39	18	54.135	48	21	45	19	60.000	60	21	42	20
49.675	51	22	45	21	54.167	55	22	39	18	60.084	55	21	39	17
49.737	45	20	42	19	54.278	55	19	45	24	60.287	60	19	42	22
49.850	51	21	39	19	54.321	55	18	48	27	60.395	51	20	45	19
50.000	55	24	48	22	54.334	45	19	39	17	60.504	48	21	45	17
50.053	48	22	39	17	54.545	60	22	48	24	60.662	55	17	45	24



CINCINNATI DIAL TYPE MILLING MACHINES

TABLE OF LEADS (60.714 to 107.843)

Lead of Spiral in Inches	Lead of Spiral in Inches				Lead of Spiral in Inches	Lead of Spiral in Inches				Lead of Spiral in Inches	Lead of Spiral in Inches			
	A	B	C	D		A	B	C	D		A	B	C	D
60.714	55	22	51	21	68.873	48	19	45	17	76.471	60	18	39	17
60.789	55	20	42	19	67.105	55	22	51	19	78.625	55	19	45	17
61.111	55	21	42	18	67.380	60	17	42	22	78.682	60	19	51	21
61.178	48	18	39	17	67.500	51	20	45	17	77.005	60	17	48	22
61.300	55	19	36	17	67.554	55	19	42	18	77.193	55	19	48	18
61.384	51	22	45	17	67.669	60	19	45	21	77.273	60	18	51	22
61.513	55	19	51	24	67.941	55	20	42	17	77.847	55	20	48	17
61.579	60	20	39	19	68.000	51	20	48	18	77.917	55	20	51	18
61.785	55	22	42	17	68.182	60	18	45	22	78.019	60	19	42	17
61.818	51	22	48	18	68.421	60	19	39	18	78.571	55	21	51	17
61.905	60	21	39	18	68.571	60	20	48	21	78.947	60	18	45	19
62.030	55	21	45	19	68.750	55	20	45	18	79.412	60	17	45	20
62.338	60	21	48	22	68.824	60	20	39	17	80.000	51	18	48	17
62.415	48	19	42	17	68.900	60	19	48	22	80.528	60	19	51	20
62.500	55	22	45	18	69.328	55	21	45	17	80.672	60	17	48	21
62.587	60	22	39	17	69.474	55	20	48	19	80.882	55	18	45	17
62.632	51	19	42	18	69.545	60	20	51	22	80.952	60	18	51	21
62.719	55	19	39	18	69.841	55	21	48	18	81.734	55	19	48	17
62.745	60	17	48	27	70.000	60	20	42	18	81.818	60	17	51	22
62.857	55	21	48	20	70.098	55	18	39	17	82.018	55	19	51	18
62.963	60	18	51	27	70.301	55	21	51	19	82.353	60	18	42	17
63.000	51	20	42	17	70.588	55	22	48	17	82.500	55	20	51	17
63.088	55	20	39	17	70.833	55	22	51	18	82.707	60	19	55	21
63.158	55	22	48	19	71.053	60	19	45	20	83.333	60	18	55	22
63.529	48	20	45	17	71.429	60	18	45	21	83.591	60	19	45	17
63.636	60	18	42	22	71.517	55	19	42	17	84.211	60	18	48	19
63.750	55	22	51	20	71.579	51	19	48	18	84.706	60	17	48	20
64.167	55	18	42	20	72.000	51	20	48	17	85.000	60	18	51	20
64.288	60	21	45	20	72.180	60	19	48	21	85.714	60	17	51	21
64.421	51	20	48	19	72.368	55	19	45	18	86.275	55	18	48	17
64.593	60	19	45	22	72.446	60	19	30	17	86.842	55	19	51	17
64.708	55	21	42	17	72.727	60	18	48	22	87.302	60	18	55	21
64.782	51	21	48	18	72.794	55	20	45	17	88.235	60	18	45	17
64.931	55	18	51	24	72.857	60	20	51	21	89.164	60	17	48	19
65.000	60	20	39	18	73.208	60	19	51	22	89.474	60	18	51	19
65.132	55	20	45	19	73.333	55	20	48	18	90.000	60	17	51	20
65.455	60	20	48	22	73.684	60	19	42	18	91.687	60	18	55	20
65.478	55	21	45	18	73.816	55	20	51	19	92.437	60	17	55	21
65.546	60	21	39	17	73.950	55	21	48	17	94.118	60	18	48	17
65.882	48	18	42	17	74.118	60	20	42	17	94.737	60	17	51	19
66.185	55	21	48	19	74.208	55	21	51	18	96.491	60	18	55	19
66.234	60	21	51	22	75.000	55	22	51	17	97.059	60	17	55	20
66.316	60	20	42	19	75.490	55	18	42	17	100.000	60	17	51	18
66.409	55	19	39	17	75.630	60	17	45	21	102.167	60	17	55	19
66.667	60	21	42	18	75.789	51	19	48	17	107.843	60	17	55	18
66.786	55	21	51	20	76.190	60	18	48	21					

NOTES

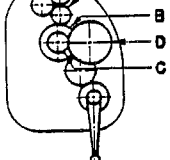

TABLE OF CHANGE GEARS, APPROXIMATE ANGLES AND ENGLISH LEADS FOR CUTTING SPIRALS

Lead of Spiral Inches	A		B		C		D		DIAMETER OF WORK																						
	Drivers	Driver	Drivers	Driver	Drivers	Driver	Drivers	Driver	1/8	3/16	1/4	5/16	3/8	7/16	1	1 1/4	1 1/2	1 3/4	2	2 1/4	2 1/2	2 3/4	3	3 1/4	3 3/4	4	4 1/2	5	5 1/2	6	
	In.	In.	In.	In.	In.	In.	In.	In.	In.	In.	In.	In.	In.	In.	In.	In.	In.	In.	In.	In.	In.	In.	In.	In.	In.	In.	In.	In.	In.	In.	In.
2.50	27	45	20	45	32	38	43 1/4	48	8 1/4	17	25	32	38	43 1/4	48	54	60	66	72	78	84	90	96	102	108	114	120	126	132	138	144
2.78	20	45	30	45	29 1/4	35 1/4	40 1/4	44 1/4	8	15 1/2	23	29 1/4	35 1/4	40 1/4	44 1/4	50 1/4	56 1/4	62 1/4	68 1/4	74 1/4	80 1/4	86 1/4	92 1/4	98 1/4	104 1/4	110 1/4	116 1/4	122 1/4	128 1/4	134 1/4	140 1/4
2.92	21	45	30	45	31	37 1/4	43 1/4	49 1/4	8 1/4	16 1/4	24 1/4	32 1/4	40 1/4	48 1/4	56 1/4	64 1/4	72 1/4	80 1/4	88 1/4	96 1/4	104 1/4	112 1/4	120 1/4	128 1/4	136 1/4	144 1/4	152 1/4	160 1/4	168 1/4	176 1/4	184 1/4
3.24	27	33	19	48	19 1/4	25 1/4	31 1/4	36	6 3/4	13 1/4	19 1/4	25 1/4	31 1/4	36	42 1/4	48 1/4	54 1/4	60 1/4	66 1/4	72 1/4	78 1/4	84 1/4	90 1/4	96 1/4	102 1/4	108 1/4	114 1/4	120 1/4	126 1/4	132 1/4	138 1/4
3.70	27	33	19	42	23	28	32 1/4	36 1/2	6	11 1/4	17 1/4	23	28	32 1/4	36 1/2	40 1/2	44 1/2	48 1/2	52 1/2	56 1/2	60 1/2	64 1/2	68 1/2	72 1/2	76 1/2	80 1/2	84 1/2	88 1/2	92 1/2	96 1/2	100 1/2
3.89	30	36	21	45	26 1/4	31 1/4	35 1/4	39	5 1/2	11 1/4	16 1/4	21 1/4	26 1/4	31 1/4	35 1/4	39	43 1/4	47 1/4	51 1/4	55 1/4	59 1/4	63 1/4	67 1/4	71 1/4	75 1/4	79 1/4	83 1/4	87 1/4	91 1/4	95 1/4	99 1/4
4.17	39	33	18	51	15 1/2	20 1/2	25 1/2	29 1/2	4 1/4	10 1/2	15 1/2	20 1/2	25 1/2	29 1/2	33 1/2	35	41 1/2	44 1/2	47 1/2	50 1/2	53 1/2	56 1/2	59 1/2	62 1/2	65 1/2	68 1/2	71 1/2	74 1/2	77 1/2	80 1/2	83 1/2
4.46	39	36	21	51	14 1/4	19 1/4	23 1/4	27 1/4	4 1/4	9 1/4	13 1/4	17 1/4	21 1/4	25 1/4	29 1/4	33	39	44 1/4	49 1/4	54 1/4	59 1/4	64 1/4	69 1/4	74 1/4	79 1/4	84 1/4	89 1/4	94 1/4	99 1/4	104 1/4	109 1/4
4.86	42	48	24	48	13 1/2	17 1/2	21 1/2	25 1/2	4 1/2	8 1/2	12 1/2	16 1/2	20 1/2	24 1/2	28 1/2	33	39	44 1/4	49 1/4	54 1/4	59 1/4	64 1/4	69 1/4	74 1/4	79 1/4	84 1/4	89 1/4	94 1/4	99 1/4	104 1/4	109 1/4
5.33	33	33	27	39	12 1/4	16 1/4	20 1/4	24 1/4	4	8	12	16	20	24 1/4	28 1/4	32 1/4	36	41 1/4	46 1/4	51 1/4	56 1/4	61 1/4	66 1/4	71 1/4	76 1/4	81 1/4	86 1/4	91 1/4	96 1/4	101 1/4	106 1/4
5.44	33	33	27	42	11 1/4	15 1/4	19 1/4	23 1/4	4	8	12	16	20	24 1/4	28 1/4	32 1/4	36	41 1/4	46 1/4	51 1/4	56 1/4	61 1/4	66 1/4	71 1/4	76 1/4	81 1/4	86 1/4	91 1/4	96 1/4	101 1/4	106 1/4
6.12	27	21	20	42	7 1/4	11 1/4	15 1/4	19 1/4	3 1/2	5 1/4	7 1/4	9 1/4	11 1/4	13 1/4	15 1/4	17 1/4	21 1/4	25 1/4	29 1/4	33 1/4	37 1/4	41 1/4	45 1/4	49 1/4	53 1/4	57 1/4	61 1/4	65 1/4	69 1/4	73 1/4	77 1/4
6.22	33	24	19	42	7 1/4	10 1/4	14 1/4	17 1/4	3 1/2	5 1/4	7 1/4	9 1/4	11 1/4	13 1/4	15 1/4	17 1/4	21 1/4	25 1/4	29 1/4	33 1/4	37 1/4	41 1/4	45 1/4	49 1/4	53 1/4	57 1/4	61 1/4	65 1/4	69 1/4	73 1/4	77 1/4
6.48	42	27	20	48	6 3/4	10 3/4	13 3/4	16 3/4	3 1/4	5 1/4	7 1/4	9 1/4	11 1/4	13 1/4	15 1/4	17 1/4	21 1/4	25 1/4	29 1/4	33 1/4	37 1/4	41 1/4	45 1/4	49 1/4	53 1/4	57 1/4	61 1/4	65 1/4	69 1/4	73 1/4	77 1/4
6.67	30	36	21	45	6 1/4	9 1/4	12 1/4	15 1/4	3 1/4	5 1/4	7 1/4	9 1/4	11 1/4	13 1/4	15 1/4	17 1/4	21 1/4	25 1/4	29 1/4	33 1/4	37 1/4	41 1/4	45 1/4	49 1/4	53 1/4	57 1/4	61 1/4	65 1/4	69 1/4	73 1/4	77 1/4
7.29	45	27	21	48	6	9	12	14 1/4	3	4 1/2	6	8 1/2	11 1/4	14 1/4	17 1/4	20 1/4	23 1/4	26 1/4	29 1/4	32 1/4	35 1/4	38 1/4	41 1/4	44 1/4	47 1/4	50 1/4	53 1/4	56 1/4	59 1/4	62 1/4	65 1/4
7.41	51	30	17	39	6	9	12	14 1/4	3	4 1/2	6	8 1/2	11 1/4	14 1/4	17 1/4	20 1/4	23 1/4	26 1/4	29 1/4	32 1/4	35 1/4	38 1/4	41 1/4	44 1/4	47 1/4	50 1/4	53 1/4	56 1/4	59 1/4	62 1/4	65 1/4
7.62	45	22	19	51	5 1/4	8 1/4	11 1/4	14 1/4	2 3/4	4 1/4	6 1/4	8 1/4	10 1/4	12 1/4	14 1/4	17 1/4	19 1/4	22 1/4	25 1/4	28 1/4	31 1/4	34 1/4	37 1/4	40 1/4	43 1/4	46 1/4	49 1/4	52 1/4	55 1/4	58 1/4	61 1/4
8.33	30	39	24	36	5 1/4	7 1/4	9 1/4	11 1/4	2 3/4	4 1/4	6 1/4	8 1/4	10 1/4	12 1/4	14 1/4	17 1/4	19 1/4	22 1/4	25 1/4	28 1/4	31 1/4	34 1/4	37 1/4	40 1/4	43 1/4	46 1/4	49 1/4	52 1/4	55 1/4	58 1/4	61 1/4
8.95	48	33	24	36	5 1/4	7 1/4	9 1/4	11 1/4	2 3/4	4 1/4	6 1/4	8 1/4	10 1/4	12 1/4	14 1/4	17 1/4	19 1/4	22 1/4	25 1/4	28 1/4	31 1/4	34 1/4	37 1/4	40 1/4	43 1/4	46 1/4	49 1/4	52 1/4	55 1/4	58 1/4	61 1/4
9.33	42	30	24	36	4 3/4	7 1/4	9 1/4	11 1/4	2 3/4	4 1/4	6 1/4	8 1/4	10 1/4	12 1/4	14 1/4	17 1/4	19 1/4	22 1/4	25 1/4	28 1/4	31 1/4	34 1/4	37 1/4	40 1/4	43 1/4	46 1/4	49 1/4	52 1/4	55 1/4	58 1/4	61 1/4
9.52	33	33	24	27	4 1/2	6 1/2	8 1/2	10 1/2	2 1/2	3 1/2	5 1/2	7 1/2	9 1/2	11 1/2	13 1/2	15 1/2	17 1/2	20 1/2	23 1/2	26 1/2	29 1/2	32 1/2	35 1/2	38 1/2	41 1/2	44 1/2	47 1/2	50 1/2	53 1/2	56 1/2	59 1/2
10.29	39	20	19	36	4 1/2	6 1/2	8 1/2	10 1/2	2 1/2	3 1/2	5 1/2	7 1/2	9 1/2	11 1/2	13 1/2	15 1/2	17 1/2	20 1/2	23 1/2	26 1/2	29 1/2	32 1/2	35 1/2	38 1/2	41 1/2	44 1/2	47 1/2	50 1/2	53 1/2	56 1/2	59 1/2
10.37	42	27	24	36	4 1/2	6 1/2	8 1/2	10 1/2	2 1/2	3 1/2	5 1/2	7 1/2	9 1/2	11 1/2	13 1/2	15 1/2	17 1/2	20 1/2	23 1/2	26 1/2	29 1/2	32 1/2	35 1/2	38 1/2	41 1/2	44 1/2	47 1/2	50 1/2	53 1/2	56 1/2	59 1/2
10.50	21	45	27	24	4 1/4	6 1/4	8 1/4	10 1/4	2 1/4	3 1/4	5 1/4	7 1/4	9 1/4	11 1/4	13 1/4	15 1/4	17 1/4	20 1/4	23 1/4	26 1/4	29 1/4	32 1/4	35 1/4	38 1/4	41 1/4	44 1/4	47 1/4	50 1/4	53 1/4	56 1/4	59 1/4
10.67	55	27	24	42	4	6 1/4	8 1/4	10 1/4	2 1/4	3 1/4	5 1/4	7 1/4	9 1/4	11 1/4	13 1/4	15 1/4	17 1/4	20 1/4	23 1/4	26 1/4	29 1/4	32 1/4	35 1/4	38 1/4	41 1/4	44 1/4	47 1/4	50 1/4	53 1/4	56 1/4	59 1/4
10.94	48	27	24	39	4	6	8	10	2	3	4	6	8	10	12	14	16	18	20	22	24	26	28	30	32	34	36	38	40	42	44
11.11	30	39	24	27	4	6	8	10	2	3	4	6	8	10	12	14	16	18	20	22	24	26	28	30	32	34	36	38	40	42	44
11.66	36	19	24	39	3 3/4	5 3/4	7 3/4	9 3/4	1 3/4	2 3/4	4 3/4	6 3/4	8 3/4	10 3/4	12 3/4	14 3/4	16 3/4	18 3/4	20 3/4	22 3/4	24 3/4	26 3/4	28 3/4	30 3/4	32 3/4	34 3/4	36 3/4	38 3/4	40 3/4	42 3/4	44 3/4
12.00	36	39	27	30	3 1/2	5 1/2	7 1/2	9 1/2	1 3/4	2 1/2	3 1/2	4 1/2	5 1/2	6 1/2	7 1/2	8 1/2	9 1/2	10 1/2	11 1/2	12 1/2	13 1/2	14 1/2	15 1/2	16 1/2	17 1/2	18 1/2	19 1/2	20 1/2	21 1/2	22 1/2	23 1/2
13.12	36	19	27	39	3 1/2	5 1/2	7 1/2	9 1/2	1 3/4	2 1/2	3 1/2	4 1/2	5 1/2	6 1/2	7 1/2	8 1/2	9 1/2	10 1/2	11 1/2	12 1/2	13 1/2	14 1/2	15 1/2	16 1/2	17 1/2	18 1/2	19 1/2	20 1/2	21 1/2	22 1/2	23 1/2
13.33	48	33	36	36	3 1/2	5 1/2	7 1/2	9 1/2	1 3/4	2 1/2	3 1/2	4 1/2	5 1/2	6 1/2	7 1/2	8 1/2	9 1/2	10 1/2	11 1/2	12 1/2	13 1/2	14 1/2	15 1/2	16 1/2	17 1/2	18 1/2	19 1/2	20 1/2	21 1/2	22 1/2	23 1/2
13.71	48	21	27	45	3 1/4	4 3/4	6 1/4	8 1/4	1 1/4	2 1/4	3 1/4	4 1/4	5 1/4	6 1/4	7 1/4	8 1/4	9 1/4	10 1/4	11 1/4	12 1/4	13 1/4	14 1/4	15 1/4	16 1/4	17 1/4	18 1/4	19 1/4	20 1/4	21 1/4	22 1/4	23 1/4

APPROXIMATE ANGLE IN DEGREES
FOR SETTING MILLING MACHINE TABLE

These tables are of special convenience for quickly setting the machine with proper change gears when the angle of spiral and the diameter of a piece of work are known. For example: To cut a spiral mill 4" diameter, 25° angle: Follow down the 4" column to the nearest angle, 26 1/4, and the change gears are 48, 36 and 18.

See pages 54 and 55 for lead and angle formulae

TABLE OF CHANGE GEARS, APPROXIMATE ANGLES, AND ENGLISH LEADS FOR CUTTING SPIRALS—(Concluded)

Lead of Spiral Inches	A		B		C		D		DIAMETER OF WORK																							
	Drives	Driver	Drives	Driver	Drives	Driver	Drives	Driver	7/8	7/4	3/2	3/4	3/8	1/2	1 1/4	1 1/2	1 3/4	2	2 1/4	2 1/2	3	3 1/2	3 3/4	4	4 1/2	5	5 1/2	6				
15.24	45	17	33	19	33	19	33	19	1 1/2	3	5 1/2	7 1/4	8 3/4	10 1/4	11 1/2	14 1/2	17 1/2	20	22 1/2	25	27 1/4	29 1/2	31 1/4	34	35 3/4	37 3/4	39 1/2	42 3/4	46	48 1/2	51	
15.56	42	36	27	24	27	24	27	24	1 1/4	2 3/4	4 1/4	5 1/2	6 3/4	8 1/4	10 1/4	12 1/4	14 1/4	16 1/4	18 1/4	20 1/4	22 1/4	24 1/4	26 1/4	28 1/4	30 1/4	32 1/4	34 1/4	36 1/4	38 1/4	40 1/4	42 1/4	44 1/4
15.75	42	24	30	27	30	27	30	27	1 1/4	2 1/2	3 1/2	4 1/2	5 1/2	6 1/2	7 1/2	8 1/2	9 1/2	10 1/2	11 1/2	12 1/2	13 1/2	14 1/2	15 1/2	16 1/2	17 1/2	18 1/2	19 1/2	20 1/2	21 1/2	22 1/2	23 1/2	24 1/2
16.87	45	24	30	27	30	27	30	27	1 1/2	2 3/4	4 1/4	5 1/2	6 3/4	8 1/4	10 1/4	12 1/4	14 1/4	16 1/4	18 1/4	20 1/4	22 1/4	24 1/4	26 1/4	28 1/4	30 1/4	32 1/4	34 1/4	36 1/4	38 1/4	40 1/4	42 1/4	44 1/4
17.14	36	39	1 1/4	2 1/2	3 1/2	4 1/2	5 1/2	6 1/2	7 1/2	8 1/2	9 1/2	10 1/2	11 1/2	12 1/2	13 1/2	14 1/2	15 1/2	16 1/2	17 1/2	18 1/2	19 1/2	20 1/2	21 1/2	22 1/2	23 1/2	24 1/2
18.75	45	36	24	1	24	1	24	1	1 1/2	2 3/4	4 1/4	5 1/2	6 3/4	8 1/4	10 1/4	12 1/4	14 1/4	16 1/4	18 1/4	20 1/4	22 1/4	24 1/4	26 1/4	28 1/4	30 1/4	32 1/4	34 1/4	36 1/4	38 1/4	40 1/4	42 1/4	44 1/4
19.59	48	21	27	36	21	27	36	21	1 1/4	2 1/2	3 1/2	4 1/2	5 1/2	6 1/2	7 1/2	8 1/2	9 1/2	10 1/2	11 1/2	12 1/2	13 1/2	14 1/2	15 1/2	16 1/2	17 1/2	18 1/2	19 1/2	20 1/2	21 1/2	22 1/2	23 1/2	24 1/2
19.69	51	19	33	45	19	33	45	19	1 1/4	2 1/2	3 1/2	4 1/2	5 1/2	6 1/2	7 1/2	8 1/2	9 1/2	10 1/2	11 1/2	12 1/2	13 1/2	14 1/2	15 1/2	16 1/2	17 1/2	18 1/2	19 1/2	20 1/2	21 1/2	22 1/2	23 1/2	24 1/2
21.43	45	36	1 1/2	2 3/4	4 1/4	5 1/2	6 3/4	8 1/4	10 1/4	12 1/4	14 1/4	16 1/4	18 1/4	20 1/4	22 1/4	24 1/4	26 1/4	28 1/4	30 1/4	32 1/4	34 1/4	36 1/4	38 1/4	40 1/4	42 1/4	44 1/4
22.50	45	36	1 1/2	2 3/4	4 1/4	5 1/2	6 3/4	8 1/4	10 1/4	12 1/4	14 1/4	16 1/4	18 1/4	20 1/4	22 1/4	24 1/4	26 1/4	28 1/4	30 1/4	32 1/4	34 1/4	36 1/4	38 1/4	40 1/4	42 1/4	44 1/4
23.33	42	36	1 1/4	2 1/2	3 1/2	4 1/2	5 1/2	6 1/2	7 1/2	8 1/2	9 1/2	10 1/2	11 1/2	12 1/2	13 1/2	14 1/2	15 1/2	16 1/2	17 1/2	18 1/2	19 1/2	20 1/2	21 1/2	22 1/2	23 1/2	24 1/2
26.25	45	30	42	30	42	30	42	30	1 1/2	2 3/4	4 1/4	5 1/2	6 3/4	8 1/4	10 1/4	12 1/4	14 1/4	16 1/4	18 1/4	20 1/4	22 1/4	24 1/4	26 1/4	28 1/4	30 1/4	32 1/4	34 1/4	36 1/4	38 1/4	40 1/4	42 1/4	44 1/4
26.67	48	36	1 1/4	2 1/2	3 1/2	4 1/2	5 1/2	6 1/2	7 1/2	8 1/2	9 1/2	10 1/2	11 1/2	12 1/2	13 1/2	14 1/2	15 1/2	16 1/2	17 1/2	18 1/2	19 1/2	20 1/2	21 1/2	22 1/2	23 1/2	24 1/2
28.00	48	36	42	30	42	30	42	30	1 1/2	2 3/4	4 1/4	5 1/2	6 3/4	8 1/4	10 1/4	12 1/4	14 1/4	16 1/4	18 1/4	20 1/4	22 1/4	24 1/4	26 1/4	28 1/4	30 1/4	32 1/4	34 1/4	36 1/4	38 1/4	40 1/4	42 1/4	44 1/4
30.88	45	36	42	30	42	30	42	30	1 1/2	2 3/4	4 1/4	5 1/2	6 3/4	8 1/4	10 1/4	12 1/4	14 1/4	16 1/4	18 1/4	20 1/4	22 1/4	24 1/4	26 1/4	28 1/4	30 1/4	32 1/4	34 1/4	36 1/4	38 1/4	40 1/4	42 1/4	44 1/4
31.50	45	30	42	30	42	30	42	30	1 1/2	2 3/4	4 1/4	5 1/2	6 3/4	8 1/4	10 1/4	12 1/4	14 1/4	16 1/4	18 1/4	20 1/4	22 1/4	24 1/4	26 1/4	28 1/4	30 1/4	32 1/4	34 1/4	36 1/4	38 1/4	40 1/4	42 1/4	44 1/4
36.00	51	30	36	17	36	17	36	17	1 1/2	2 3/4	4 1/4	5 1/2	6 3/4	8 1/4	10 1/4	12 1/4	14 1/4	16 1/4	18 1/4	20 1/4	22 1/4	24 1/4	26 1/4	28 1/4	30 1/4	32 1/4	34 1/4	36 1/4	38 1/4	40 1/4	42 1/4	44 1/4
41.14	48	21	36	42	21	36	42	21	1 1/2	2 3/4	4 1/4	5 1/2	6 3/4	8 1/4	10 1/4	12 1/4	14 1/4	16 1/4	18 1/4	20 1/4	22 1/4	24 1/4	26 1/4	28 1/4	30 1/4	32 1/4	34 1/4	36 1/4	38 1/4	40 1/4	42 1/4	44 1/4
45.00	55	22	36	42	22	36	42	22	1 1/2	2 3/4	4 1/4	5 1/2	6 3/4	8 1/4	10 1/4	12 1/4	14 1/4	16 1/4	18 1/4	20 1/4	22 1/4	24 1/4	26 1/4	28 1/4	30 1/4	32 1/4	34 1/4	36 1/4	38 1/4	40 1/4	42 1/4	44 1/4
48.00	55	21	42	20	42	20	42	20	1 1/2	2 3/4	4 1/4	5 1/2	6 3/4	8 1/4	10 1/4	12 1/4	14 1/4	16 1/4	18 1/4	20 1/4	22 1/4	24 1/4	26 1/4	28 1/4	30 1/4	32 1/4	34 1/4	36 1/4	38 1/4	40 1/4	42 1/4	44 1/4
51.43	48	21	42	20	42	20	42	20	1 1/2	2 3/4	4 1/4	5 1/2	6 3/4	8 1/4	10 1/4	12 1/4	14 1/4	16 1/4	18 1/4	20 1/4	22 1/4	24 1/4	26 1/4	28 1/4	30 1/4	32 1/4	34 1/4	36 1/4	38 1/4	40 1/4	42 1/4	44 1/4
60.00	60	21	42	20	42	20	42	20	1 1/2	2 3/4	4 1/4	5 1/2	6 3/4	8 1/4	10 1/4	12 1/4	14 1/4	16 1/4	18 1/4	20 1/4	22 1/4	24 1/4	26 1/4	28 1/4	30 1/4	32 1/4	34 1/4	36 1/4	38 1/4	40 1/4	42 1/4	44 1/4
63.00	60	20	42	17	42	17	42	17	1 1/2	2 3/4	4 1/4	5 1/2	6 3/4	8 1/4	10 1/4	12 1/4	14 1/4	16 1/4	18 1/4	20 1/4	22 1/4	24 1/4	26 1/4	28 1/4	30 1/4	32 1/4	34 1/4	36 1/4	38 1/4	40 1/4	42 1/4	44 1/4
65.00	60	20	42	18	42	18	42	18	1 1/2	2 3/4	4 1/4	5 1/2	6 3/4	8 1/4	10 1/4	12 1/4	14 1/4	16 1/4	18 1/4	20 1/4	22 1/4	24 1/4	26 1/4	28 1/4	30 1/4	32 1/4	34 1/4	36 1/4	38 1/4	40 1/4	42 1/4	44 1/4
70.00	60	20	42	17	42	17	42	17	1 1/2	2 3/4	4 1/4	5 1/2	6 3/4	8 1/4	10 1/4	12 1/4	14 1/4	16 1/4	18 1/4	20 1/4	22 1/4	24 1/4	26 1/4	28 1/4	30 1/4	32 1/4	34 1/4	36 1/4	38 1/4	40 1/4	42 1/4	44 1/4
72.00	51	20	48	17	48	17	48	17	1 1/2	2 3/4	4 1/4	5 1/2	6 3/4	8 1/4	10 1/4	12 1/4	14 1/4	16 1/4	18 1/4	20 1/4	22 1/4	24 1/4	26 1/4	28 1/4	30 1/4	32 1/4	34 1/4	36 1/4	38 1/4	40 1/4	42 1/4	44 1/4
75.00	55	22	51	17	51	17	51	17	1 1/2	2 3/4	4 1/4	5 1/2	6 3/4	8 1/4	10 1/4	12 1/4	14 1/4	16 1/4	18 1/4	20 1/4	22 1/4	24 1/4	26 1/4	28 1/4	30 1/4	32 1/4	34 1/4	36 1/4	38 1/4	40 1/4	42 1/4	44 1/4
80.00	51	18	48	17	48	17	48	17	1 1/2	2 3/4	4 1/4	5 1/2	6 3/4	8 1/4	10 1/4	12 1/4	14 1/4	16 1/4	18 1/4	20 1/4	22 1/4	24 1/4	26 1/4	28 1/4	30 1/4	32 1/4	34 1/4	36 1/4	38 1/4	40 1/4	42 1/4	44 1/4
85.00	60	18	51	20	51	20	51	20	1 1/2	2 3/4	4 1/4	5 1/2	6 3/4	8 1/4	10 1/4	12 1/4	14 1/4	16 1/4	18 1/4	20 1/4	22 1/4	24 1/4	26 1/4	28 1/4	30 1/4	32 1/4	34 1/4	36 1/4	38 1/4	40 1/4	42 1/4	44 1/4
85.00	60	17	51	20	51	20	51	20	1 1/2	2 3/4	4 1/4	5 1/2	6 3/4	8 1/4	10 1/4	12 1/4	14 1/4	16 1/4	18 1/4	20 1/4	22 1/4	24 1/4	26 1/4	28 1/4	30 1/4	32 1/4	34 1/4	36 1/4	38 1/4	40 1/4	42 1/4	44 1/4
90.00	60	17	51	20	51	20	51	20	1 1/2	2 3/4	4 1/4	5 1/2	6 3/4	8 1/4	10 1/4	12 1/4	14 1/4	16 1/4	18 1/4	20 1/4	22 1/4	24 1/4	26 1/4	28 1/4	30 1/4	32 1/4	34 1/4	36 1/4	38 1/4	40 1/4	42 1/4	44 1/4
100.00	60	17	51	18	51	18	51	18	1 1/2	2 3/4	4 1/4	5 1/2	6 3/4	8 1/4	10 1/4	12 1/4	14 1/4	16 1/4	18 1/4	20 1/4	22 1/4	24 1/4	26 1/4	28 1/4	30 1/4	32 1/4	34 1/4	36 1/4	38 1/4	40 1/4	42 1/4	44 1/4
107.80	60	17	55	18	55	18	55	18	1 1/2	2 3/4	4 1/4	5 1/2	6 3/4	8 1/4	10 1/4	12 1/4	14 1/4	16 1/4	18 1/4	20 1/4	22 1/4	24 1/4	26 1/4	28 1/4	30 1/4	32 1/4	34 1/4	36 1/4	38 1/4	40 1/4	42 1/4	44 1/4

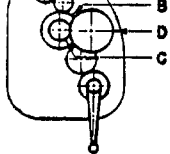

**ENGLISH LEADS AND CHANGE GEARS
FOR MILLING SPIRAL END MILLS**

Set Machine Table to Angle of Approximately 20 Degrees

Diameter of Mill, Inches	Lead in Inches	Driven A	Driver B	Driven C	Driver D
3/8	3.24	27	38	19	48
1/2	4.32	36	33	19	48
5/8	5.40	45	33	19	48
3/4	6.48	42	27	20	48
7/8	7.56	42	22	19	48
1	8.64	42	27	20	36
1 1/8	9.72	45	27	21	36
1 1/4	10.79	36	20	27	45
1 3/8	11.87	36	21	27	39
1 1/2	12.94	22	45	..	17
1 3/4	15.11	48	22	27	39
2	17.28	51	19	27	42
2 1/4	19.41	33	36	..	17
2 1/2	21.58	51	20	33	39
2 3/4	23.73	55	17	22	30
3	25.88	55	17	36	45
3 1/4	28.05	51	30	33	20
3 1/2	30.22	51	30	48	27
3 3/4	32.38	51	27	36	21
4	34.53	51	24	39	24

**ENGLISH LEADS AND CHANGE GEARS
FOR MILLING SPIRAL MILLING CUTTERS**

Set Machine Table to Angle of Approximately 25 Degrees

Diameter of Mill, Inches	Lead in Inches	Driven A	Driver B	Driven C	Driver D
1/2	3.37	27	33	21	51
5/8	4.22	27	24	18	48
3/4	5.06	30	33	20	36
7/8	5.89	33	36	27	42
1	6.74	39	27	21	45
1 1/4	8.42	48	19	17	51
1 1/2	10.11	42	22	27	51
1 3/4	11.79	42	19	42	45
2	13.47	36	21	33	42
2 1/4	15.16	48	19	27	45
2 1/2	16.84	48	19	30	45
2 3/4	18.53	42	17	36	48
3	20.20	60	27	30	33
3 1/4	21.90	48	19	39	45
3 1/2	23.58	48	19	42	45
3 3/4	25.26	48	33	..	19
4	26.95	42	33	36	17
4 1/4	28.63	51	19	48	45
4 1/2	30.32	48	30	36	19
4 3/4	32.00	48	21	42	30
5	33.69	45	33	42	17
5 1/4	35.37	48	30	42	19
5 1/2	37.06	45	30	42	17
5 3/4	38.76	45	22	36	19
6	40.43	42	22	36	17

TABLE OF TANGENTS

(Natural Tangents at Intervals of 1/4°)

Degrees	Tangent	Degrees	Tangent	Degrees	Tangent	Degrees	Tangent	Degrees	Tangent	Degrees	Tangent	Degrees	Tangent
0°	.0000	13°	.2309	26°	.4877	39°	.8098	52°	1.290	65°	2.145	78°	4.705
1/4°	.0044	13 1/4°	.2355	26 1/4°	.4931	39 1/4°	.8170	52 1/4°	1.292	65 1/4°	2.169	78 1/4°	4.808
1/2°	.0087	13 1/2°	.2401	26 1/2°	.4986	39 1/2°	.8243	52 1/2°	1.303	65 1/2°	2.194	78 1/2°	4.915
3/4°	.0131	13 3/4°	.2447	26 3/4°	.5040	39 3/4°	.8317	52 3/4°	1.315	65 3/4°	2.220	78 3/4°	5.027
1°	.0175	14°	.2493	27°	.5095	40°	.8391	53°	1.327	66°	2.246	79°	5.145
1 1/4°	.0218	14 1/4°	.2540	27 1/4°	.5150	40 1/4°	.8466	53 1/4°	1.339	66 1/4°	2.273	79 1/4°	5.267
1 1/2°	.0262	14 1/2°	.2586	27 1/2°	.5206	40 1/2°	.8541	53 1/2°	1.351	66 1/2°	2.300	79 1/2°	5.396
1 3/4°	.0306	14 3/4°	.2633	27 3/4°	.5261	40 3/4°	.8617	53 3/4°	1.364	66 3/4°	2.328	79 3/4°	5.530
2°	.0349	15°	.2680	28°	.5317	41°	.8693	54°	1.376	67°	2.356	80°	5.671
2 1/4°	.0393	15 1/4°	.2726	28 1/4°	.5373	41 1/4°	.8770	54 1/4°	1.389	67 1/4°	2.385	80 1/4°	5.820
2 1/2°	.0437	15 1/2°	.2773	28 1/2°	.5430	41 1/2°	.8847	54 1/2°	1.402	67 1/2°	2.414	80 1/2°	5.976
2 3/4°	.0480	15 3/4°	.2820	28 3/4°	.5486	41 3/4°	.8925	54 3/4°	1.416	67 3/4°	2.444	80 3/4°	6.140
3°	.0524	16°	.2867	29°	.5543	42°	.9004	55°	1.428	68°	2.475	81°	6.314
3 1/4°	.0568	16 1/4°	.2915	29 1/4°	.5600	42 1/4°	.9083	55 1/4°	1.442	68 1/4°	2.507	81 1/4°	6.497
3 1/2°	.0612	16 1/2°	.2962	29 1/2°	.5658	42 1/2°	.9163	55 1/2°	1.455	68 1/2°	2.539	81 1/2°	6.691
3 3/4°	.0655	16 3/4°	.3010	29 3/4°	.5716	42 3/4°	.9244	55 3/4°	1.469	68 3/4°	2.572	81 3/4°	6.897
4°	.0699	17°	.3057	30°	.5774	43°	.9325	56°	1.483	69°	2.605	82°	7.115
4 1/4°	.0743	17 1/4°	.3105	30 1/4°	.5832	43 1/4°	.9407	56 1/4°	1.497	69 1/4°	2.639	82 1/4°	7.348
4 1/2°	.0787	17 1/2°	.3153	30 1/2°	.5890	43 1/2°	.9490	56 1/2°	1.511	69 1/2°	2.675	82 1/2°	7.596
4 3/4°	.0831	17 3/4°	.3201	30 3/4°	.5949	43 3/4°	.9573	56 3/4°	1.525	69 3/4°	2.711	82 3/4°	7.861
5°	.0875	18°	.3249	31°	.6009	44°	.9657	57°	1.540	70°	2.748	83°	8.144
5 1/4°	.0919	18 1/4°	.3298	31 1/4°	.6068	44 1/4°	.9742	57 1/4°	1.555	70 1/4°	2.785	83 1/4°	8.449
5 1/2°	.0963	18 1/2°	.3346	31 1/2°	.6128	44 1/2°	.9827	57 1/2°	1.570	70 1/2°	2.824	83 1/2°	8.777
5 3/4°	.1007	18 3/4°	.3395	31 3/4°	.6188	44 3/4°	.9913	57 3/4°	1.585	70 3/4°	2.864	83 3/4°	9.131
6°	.1051	19°	.3443	32°	.6249	45°	1.000	58°	1.600	71°	2.904	84°	9.514
6 1/4°	.1095	19 1/4°	.3492	32 1/4°	.6310	45 1/4°	1.009	58 1/4°	1.616	71 1/4°	2.946	84 1/4°	9.931
6 1/2°	.1139	19 1/2°	.3541	32 1/2°	.6371	45 1/2°	1.018	58 1/2°	1.632	71 1/2°	2.989	84 1/2°	10.385
6 3/4°	.1184	19 3/4°	.3590	32 3/4°	.6432	45 3/4°	1.027	58 3/4°	1.648	71 3/4°	3.033	84 3/4°	10.883
7°	.1228	20°	.3640	33°	.6494	46°	1.036	59°	1.664	72°	3.078	85°	11.400
7 1/4°	.1272	20 1/4°	.3689	33 1/4°	.6556	46 1/4°	1.045	59 1/4°	1.681	72 1/4°	3.124	85 1/4°	12.035
7 1/2°	.1317	20 1/2°	.3739	33 1/2°	.6619	46 1/2°	1.054	59 1/2°	1.698	72 1/2°	3.172	85 1/2°	12.706
7 3/4°	.1361	20 3/4°	.3789	33 3/4°	.6682	46 3/4°	1.063	59 3/4°	1.715	72 3/4°	3.221	85 3/4°	13.457
8°	.1405	21°	.3839	34°	.6745	47°	1.072	60°	1.732	73°	3.271	86°	14.301
8 1/4°	.1450	21 1/4°	.3889	34 1/4°	.6809	47 1/4°	1.082	60 1/4°	1.750	73 1/4°	3.323	86 1/4°	15.257
8 1/2°	.1495	21 1/2°	.3939	34 1/2°	.6873	47 1/2°	1.091	60 1/2°	1.768	73 1/2°	3.376	86 1/2°	16.350
8 3/4°	.1539	21 3/4°	.3990	34 3/4°	.6937	47 3/4°	1.101	60 3/4°	1.786	73 3/4°	3.431	86 3/4°	17.610
9°	.1584	22°	.4040	35°	.7002	48°	1.111	61°	1.804	74°	3.487	87°	19.081
9 1/4°	.1629	22 1/4°	.4091	35 1/4°	.7067	48 1/4°	1.121	61 1/4°	1.823	74 1/4°	3.547	87 1/4°	20.819
9 1/2°	.1673	22 1/2°	.4142	35 1/2°	.7133	48 1/2°	1.130	61 1/2°	1.842	74 1/2°	3.606	87 1/2°	22.904
9 3/4°	.1718	22 3/4°	.4193	35 3/4°	.7199	48 3/4°	1.140	61 3/4°	1.861	74 3/4°	3.668	87 3/4°	24.452
10°	.1763	23°	.4245	36°	.7265	49°	1.150	62°	1.881	75°	3.732	88°	28.636
10 1/4°	.1808	23 1/4°	.4296	36 1/4°	.7332	49 1/4°	1.161	62 1/4°	1.901	75 1/4°	3.798	88 1/4°	32.730
10 1/2°	.1853	23 1/2°	.4348	36 1/2°	.7400	49 1/2°	1.171	62 1/2°	1.921	75 1/2°	3.867	88 1/2°	38.188
10 3/4°	.1899	23 3/4°	.4400	36 3/4°	.7467	49 3/4°	1.181	62 3/4°	1.942	75 3/4°	3.938	88 3/4°	45.820
11°	.1944	24°	.4452	37°	.7536	50°	1.192	63°	1.963	76°	4.011	89°	57.29
11 1/4°	.1989	24 1/4°	.4505	37 1/4°	.7604	50 1/4°	1.202	63 1/4°	1.984	76 1/4°	4.087	89 1/4°	76.39
11 1/2°	.2035	24 1/2°	.4557	37 1/2°	.7673	50 1/2°	1.213	63 1/2°	2.006	76 1/2°	4.165	89 1/2°	114.59
11 3/4°	.2080	24 3/4°	.4610	37 3/4°	.7743	50 3/4°	1.224	63 3/4°	2.028	76 3/4°	4.247	89 3/4°	229.18
12°	.2126	25°	.4663	38°	.7813	51°	1.235	64°	2.050	77°	4.332	90°	
12 1/4°	.2171	25 1/4°	.4716	38 1/4°	.7883	51 1/4°	1.246	64 1/4°	2.073	77 1/4°	4.419		
12 1/2°	.2217	25 1/2°	.4770	38 1/2°	.7954	51 1/2°	1.257	64 1/2°	2.097	77 1/2°	4.511		
12 3/4°	.2263	25 3/4°	.4823	38 3/4°	.8026	51 3/4°	1.269	64 3/4°	2.120	77 3/4°	4.606		

ORDERING REPAIR PARTS

You will receive quicker service when ordering repair parts if you will adhere to the following procedure:

1. **State amount wanted.**
2. **Give part number and name or description of part, and where obtained.**
 - (a) Parts catalog.
 - (b) Part number stamped on part.
 - (c) Prior invoice.
3. **Give complete serial number of machine.** The serial number will be found stamped in two places: Horizontal Machines, on the face of the column near the spindle, and front of the table near the right hand end. Vertical Machines, top of the scraped bearing for the knee and front of the table near the right hand end.
4. **Specify each individual piece required.** If only certain parts of a unit are required, never use the word "complete"; it always raises the question as to how much of the unit to supply. In some cases, due to the nature of the parts, it will be less costly to you for us to supply additional related pieces, especially if part wanted is obsolete.
5. **Specify how and where to ship.** Do not say "Ship quickest way". Be definite and state the agency desired, that is:—Air Mail, Parcel Post, Special Delivery, Express, Motor Freight, Rail Freight, etc.

NOTES

ALPHABETICAL INDEX

	Page		Page
Accessories and Attachments		Angular Indexing	55
Angle Plates	71	Approach of Cutters—Tables	92-93
Arbors	60	Arbor—Quick Change Face Mill	68
Cam Milling Attachment	87	Arbors	60
Chuck	72	Assembling the Table to the Machine	17
Circular Milling Attachment	84-86, 88, 89	Backlash Eliminator (Plain and Vertical Machines)	
Collet Adapter (50 to 40)	68	Adjustment	64
Compensating Dog and Driver	70	Engaging and Disengaging	64
Enclosed Driving Mechanism	80	General Discussion	62-63
Four Position Turret Stop and Dial Indicator	30	Operation	63-64
Heavy Vertical Attachment	79	Backlash Eliminator (Universal Machines)	
High Number Indexing Attachment	69	Adjustment	65
High Speed Universal Milling Attachment	75-76	Engaging and Disengaging	65
High Tailstock	70	Bearings	
Motor Driven Coolant Pump	81	Adjustments, Cross Feed Screw	41
Motor Driven Universal Milling Overarm Attachment	77	Adjustments, Spindle	42-43
Mounting a Chuck on the Dividing Head	72	Adjustments, Table Feed Screw	40
Quick Change Adapter, Shell End Mills, Arbors, and Collets	67	Blocks—Raising	71
Quick Change Face Mill Arbor	68	Bolting the Machine to the Floor	18
Rack Indexing Attachment	83	Blocks, Overarm, and Supports	30
Rack Milling Attachment	82	Calculations	
Raising Blocks	71	Angle for Setting the Milling Machine Table or Spiral Milling Attachment	54
Short and Long Lead Attachment	81	Change Gears Required for a Given Lead	52
Spiral Milling Head	73	Indexing with the Side Plate	54-55
Universal Spiral Milling Attachment	74	Machining Time	90-93
Vises	78, 79	Milling Cams	61
Adapter—Collet	68	Calculator—Speed	34
Adjustments		Cam Milling Attachment	87
Backlash Eliminator (Plain and Vertical Machines)	64	Cams—Milling	61
Backlash Eliminator (Universal Machines)	65	Cast Iron and Steel Set-Ups	33
Cross Feed Screw Bearings	41	Change Gears	
Dividing Head Worm	57	Angles and Leads	118-119
Driving Clutch	38-39	How to Select	51
Gibs	37	Changing Feeds	25-26
Rapid Traverse Clutch	39	Changing Spindle Speeds	23
Rapid Traverse Plunger too High	39	Chart—Lubrication	20
Setting the Oil Pressure of Pump in Column	44	Chuck	72
Speed Gears Fail to Shift	43	Circular Milling Attachment	84-86
Spindle Bearings	42-43	Feeds Obtained	88-89
Table Feed Screw Bearings	40	Clamping Devices for Sliding Units	30
Tension in the V-Belts	37	Clamping the Dividing Head Spindle in Place	57
Agents and Direct Sales Offices	128	Clamping the Head in Position	29
Angle for Setting the Milling Machine Table or Spiral Milling Attachment—How to Calculate	54	Cleaning the Coolant Reservoir	36
Angle Plates	71	Clutch	
Angles, Change Gears, and Leads	118-119	Adjustment, Driving	38-39
Angular Divisions	98-99	Adjustment, Rapid Traverse	39

ALPHABETICAL INDEX—Continued

	Page		Page
Collet Adapter (50 to 40).....	68	Divisions—Angular.....	98-99
Collets, Arbors, Shell End Mills, and Quick Change Adapter.....	67	Dogs—Trip.....	32
Column Reservoir—Filling.....	19	Driving Clutch—Adjustment.....	38-39
Compensating Dog and Driver.....	70	Driving Mechanism—Enclosed.....	80
Conversion to Short Leads— Emergency.....	52	Eliminator—Backlash (Plain and Vertical Machines).....	62-64
Coolant Pump—Motor Driven.....	81	Eliminator—Backlash (Universal Machines).....	65
Coolant Reservoir—Cleaning.....	36	Emergency Conversion to Short Leads.....	52
Cross Feed Screw Bearings— Adjustment.....	41	Enclosed Driving Mechanism.....	80
Cutters		Engaging and Disengaging the Backlash Eliminator	
Setting Up the Fixture.....	33	Plain and Vertical Machines.....	64
Table for Approach of.....	92-93	Universal Machines.....	65
Table for Milling Spiral Milling.....	120	End Mills—Table for Milling Spiral... ..	120
Cutting Fluids.....	35	Equipment Supplied with the Machine—Standard.....	16
Cutting Racks—Table.....	83	Face Mill Arbor—Quick Change.....	68
Description and Specifications of Dividing Head.....	46-47	Feeds.....	25
Diagram—Functional.....	22	Feed Levers	
Dimensional Drawings and Machine Dimensions.....	10-15	Hand.....	23-24
Dimensions of Machines and Dimensional Drawings.....	10-15	Power.....	24-25
Direction of Rotation of Spindle— Reversing.....	30	Feed Rates—Rapid Traverse and High.....	53
Direct Sales Offices and Agents.....	128	Feeds—Changing.....	25-26
Divider—Wide Range.....	58-60	Feed Screw Bearings	
Dividing Head		Adjustments, Cross.....	41
Adjusting the Dividing Head Worm.....	57	Adjustments, Table.....	40
Angular Indexing.....	55	Feeds Obtained with Circular Milling Attachment.....	87-89
Calculating the Change Gears Required for a Given Lead.....	52	Filling the Column Oil Reservoir... ..	19
Clamping the Dividing Head Spindle in Place.....	57	Fixture and Cutters—Setting Up....	33
Description and Specifications.....	46-47	Fluids—Cutting.....	35
Emergency Conversion to Short Leads.....	52	Foundation.....	17
How to Calculate Indexing with the Side Plate.....	54-55	Four Position Turret Stop and Dial Indicator.....	29
How to Calculate the Angle for Set- ting the Milling Machine Table or Spiral Milling Attachment.....	54	Front Plate—Indexing.....	56
How to Select the Proper Change Gears.....	51	Functional Diagram.....	22
Indexing with the Front Plate.....	56	Gibs—Adjustment.....	37
Index Plate Stop.....	48-49	Hand Feed Levers.....	23-24
Leads Near the Low Range.....	53	Heavy Vertical Attachment.....	79
Rapid Traverse and High Feed Rates.....	53	High Feed Rates and Rapid Traverse.....	53
Sector.....	48	High Number Indexing Attachment	69
Setting Up the Change Gear Segment	51		
Setting Up the Dividing Head and Driving Mechanism.....	49-51		

ALPHABETICAL INDEX—Continued

	Page		Page
High Number Index Table (Numerical Divisions).....	96-97	Motor Driven Universal Milling Overarm Attachment.....	77
High Speed Universal Milling Attachment.....	75-76	Mounting a Chuck on the Dividing Head.....	72
High Tailstock.....	70	Numerical Divisions High Number Index Tables.....	96-97
How to Calculate Indexing with the Side Plate.....	54-55	Standard Index Tables.....	95
How to Calculate the Angle for Set- ting the Milling Machine Table or Spiral Milling Attachment..	54	Oil Pressure of Pump in Column— Setting.....	44
How to Select the Proper Change Gears.....	51	Operating Instructions.....	23-29
How to Use the Wide Range Divider.	58	Operation of Backlash Eliminator (Plain and Vertical Machines)....	63-64
Illustration Showing Set-Up Elements.....	31	Ordering Repair Parts.....	122
Indexing—Angular.....	55	Overarm, Supports, and Braces....	30
Indexing Attachment—High Number	69	Parts—Ordering Repair.....	122
Indexing with the Front Plate.....	56	Plates—Angle.....	71
Indexing with the Side Plate— How to Calculate.....	54-55	Power Feed and Power Rapid Traverse to Head on Vertical Machines.....	27-29
Index Plate—Reversing the Large....	60	Power Feed Levers.....	24-25
Index Plate Stop.....	48-49	Power Rapid Traverse.....	26-27, 29
Index Tables (Angular Divisions)....	98-99	Precautions—Safety.....	45
Index Tables (Numerical Divisions)— Standard.....	95	Principal Machine Specifications....	9
Installation.....	17-18	Proper Change Gears—How to Select.....	51
Instructions—Operating.....	23-29	Pump in Column—Setting the Oil Pressure.....	44
Leads, Angles, and Change Gears. 118-119		Pump—Motor Driven Coolant.....	81
Leads Near the Low Range.....	53	Quick Change Adapter, Shell End Mills, Arbors, and Collets.....	67
Leads—Table.....	100-116	Quick Change Face Mill Arbor.....	68
Leveling.....	18	Rack Milling Attachment.....	82
Levers		Racks—Table for Cutting.....	83
Hand Feed.....	23-24	Raising Blocks.....	71
Power Feed.....	24-25	Rapid Hand Feed.....	28
Lifting the Machine.....	17	Rapid Traverse and High Feed Rates	53
Long and Short Lead Attachment..	81	Rapid Traverse and Power Feed to Head on Vertical Machines....	27-29
Lubrication		Rapid Traverse Clutch—Adjustment.	39
Chart.....	20	Rapid Traverse Plunger too High. ...	39
Filling the Column Oil Reservoir....	19	Rapid Traverse—Power.....	26-27
Specifications.....	21	Repair Parts—Ordering.....	122
Machine Dimensions and Dimensional Drawings.....	10-15	Reservoir	
Machine Specifications—Principal... 9		Cleaning the Coolant.....	36
Method of Calculating Machining Time.....	90-93	Filling the Column Oil.....	19
Milling Cams.....	61	Reversing the Direction of Rotation of Spindle.....	30
Milling Spiral End Mills—Table....	120	Reversing the Large Index Plate....	60
Milling Spiral Milling Cutters— Table.....	120	Rotation of Spindle—Reversing....	30
Motor Driven Coolant Pump.....	81		

ALPHABETICAL INDEX—Concluded

	Page		Page
Safety Precautions.....	45	Table Feed Screw Bearings— Adjustment.....	40
Sector.....	48	Tables	
Setting the Milling Machine Table or Spiral Milling Attachment— How to Calculate the Angle.....	54	Approach of Cutters.....	92-93
Setting the Oil Pressure of Pump in Column Reservoir.....	44	Change Gears, Angles, and Leads.....	118-119
Setting Up the Change Gear Segment.....	51	Cutting Racks.....	83
Setting Up the Dividing Head and Driving Mechanism.....	49-51	Feeds Obtained with Circular Milling Attachment.....	87-89
Setting Up Fixture and Cutters.....	33	High Number Index (Numerical Divisions).....	96-97
Setting Up the Machine.....	30-34	Index (Angular Divisions).....	98-99
Set-Up Elements—Illustration.....	31	Leads.....	100-116
Shell End Mills, Arbors, Collets, and Quick Change Adapter.....	67	Milling Spiral End Mills.....	120
Short and Long Lead Attachment.....	81	Milling Spiral Milling Cutters.....	120
Short Leads—Emergency Conversion.....	52	Standard Index (Numerical Divisions).....	95
Sliding Units—Clamping Devices.....	30	Tangents.....	121
Slow Hand Feed.....	28	Trip Dogs.....	32
Specifications		Turret Stop and Dial Indicator— Four Position.....	29
Dimensional Drawings and Machine Dimensions.....	10-15	Universal Milling Attachment— High Speed.....	75-76
Dividing Head.....	47	Universal Milling Overarm Attachment—Motor Driven.....	77
Lubrication.....	21	Universal Spiral Milling Attachment.....	74
Principal Machine.....	9	V-Belts—Adjusting Tension.....	37
Speed Calculator.....	34	Vertical Attachment—Heavy.....	79
Speed Gears Fail to Shift.....	43	Vertical Machines	
Spindle Bearings—Adjustment.....	42-43	Clamping the Head in Position.....	29
Spindle Speeds—Changing.....	23	Four Position Turret Stop and Dial Indicator.....	29
Spiral End Mills—Table for Milling.....	120	Power Feed.....	28
Spiral Milling Attachment— Universal.....	74	Power Feed and Power Rapid Traverse.....	27
Spiral Milling Cutters—Table for Milling.....	120	Power Rapid Traverse.....	29
Spiral Milling Head.....	73	Rapid Hand Feed.....	28
Standard Equipment Supplied with the Machine.....	16	Slow Hand Feed.....	28
Standard Index Tables (Numerical Divisions).....	95	Trip Dogs.....	29
Starting the Machine.....	23	Vises.....	78-79
Starting the Machine for the First Time.....	19	Wide Range Divider	
Steel and Cast Iron Set-Ups.....	33	Adjusting the Index Pin on the Small Plate.....	60
Supports, Overarm, and Braces.....	30	Angular Divisions.....	59-60
		How to Use the Wide Range Divider.....	58
		Reversing the Large Index Plate.....	60

DIRECT FIELD ENGINEERING OFFICES
CINCINNATI MILLING AND GRINDING MACHINES, INC.

CONNECTICUT, WEST HARTFORD 7
10 North Main St.

ILLINOIS, CHICAGO 12
2400 West Madison St.

MASSACHUSETTS, BOSTON 16
724 Stetler Bldg.

MICHIGAN, DETROIT 2
426 New Center Bldg.

NEW YORK, BUFFALO 7
1807 Elmwood Ave.

NEW YORK, NEW YORK 17
155 East 44th St.

NEW YORK, SYRACUSE 2
472 South Salina St.

OHIO, CINCINNATI 9
4701 Marburg Ave.

OHIO, CLEVELAND 3
4614 Prospect Ave.

PENNSYLVANIA, PHILADELPHIA 40
3701 North Broad St.

PENNSYLVANIA, PITTSBURGH 22
1207 Empire Bldg.

SALES REPRESENTATIVES
UNITED STATES

ALABAMA, BIRMINGHAM 3
McVoy-Hausman Co., 2024 Sixth Ave., N.

CALIFORNIA, LOS ANGELES 11
Harron, Rickard & McCone Co. of Southern California,
3850 Santa Fe Ave.

CALIFORNIA, SAN FRANCISCO 10
Harron, Rickard & McCone Co. of Northern California
2070 Bryant St.

COLORADO, DENVER 2
Oversgard Machine Tool Co., 838 Symes Bldg.

FLORIDA, JACKSONVILLE 3
Farquhar Machinery Co., 720-728 West Bay St.

GEORGIA, ATLANTA 3
Chandler Machinery Co., 120 Houston St., N. E.

IDAHO, BOISE
Salt Lake Hardware Co., 401 S. Eighth St., P. O. Box 1489

INDIANA, INDIANAPOLIS 4
Marshall & Huchart Machinery Co. of Indiana
628 Chamber of Commerce Bldg.

LOUISIANA, NEW ORLEANS 4
J. F. Dohen, Carondelet Bldg., P. O. Box 1154

MINNESOTA, DULUTH
Anderson Machine Tool Co., 26 N. Fourth Ave., West

MINNESOTA, ST. PAUL 4
Anderson Machine Tool Co., 2645 University Ave.

MISSOURI, ST. LOUIS 8
Robert R. Stephens Machinery Co.,
1505 Continental Bldg., 1706 Olive St.

NEBRASKA, OMAHA 8
T. S. McShane Co., 1113 Howard St.

NORTH CAROLINA, ASHEVILLE
Tidewater Supply Co., 95 Roberts St., P. O. Box 212

OREGON, PORTLAND 4
Hallidie Machinery Co., Room 614 Medical Arts Bldg.
1020 S. W. Taylor

SOUTH CAROLINA, COLUMBIA, E.
Tidewater Supply Co., 1220-1224 Lincoln St., P. O. Box

TENNESSEE, CHATTANOOGA 1
Noland Co., Inc., 115 Market St.

TENNESSEE, MEMPHIS 2
Hays Machine Tool Co., 269 S. Front St.

TEXAS, DALLAS 2
Dave O'Neill Machinery Co., 520 Park Ave.

TEXAS, HOUSTON 1
S. H. Penny, 408 Petroleum Bldg.

UTAH, SALT LAKE CITY 9
Salt Lake Hardware Co., 101 N. Third St., W., P. O. Box 510

VIRGINIA, NORFOLK 1
Tidewater Supply Co., Inc., 36-44 Commercial Place

WASHINGTON, SEATTLE 4
Hallidie Machinery Co., 646 Holgate Street S.

U. S. TERRITORIES

HAWAII, HONOLULU 2, H. S. Gray Co., 74 S. Queen St. P. O. Box 3016

CANADA

B. C., VANCOUVER
B. C. Equipment Co., Ltd., B. C. Equipment Bldg.,
551 Howe St.

MANITOBA, WINNIPEG
John Bertram & Sons Co., Ltd., 1205 McArthur Bldg.

ONTARIO, DUNDAS
John Bertram & Sons Co., Ltd.

ONTARIO, TORONTO 1
John Bertram & Sons Co., Ltd., Room 614,
Commerce & Transportation Bldg., 159 Bay St.

ONTARIO, WALKERVILLE
John Bertram & Sons Co., Ltd., 16 Imperial Block,
Wyandotte St.

QUEBEC, MONTREAL
John Bertram & Sons Co., Ltd., 319 Drummond Bldg.